

Exhibit A



RFB #26-74-B MINOR HOUSING REHABILITATION PROGRAM (HVAC REPAIR/REPLACE PROGRAM)

INTRODUCTION

The City of Lewisville is requesting competitive sealed bids from qualified contractors for the repair and/or replacement of HVAC units at 14 residential homes, which have been approved through the City's Minor Housing Rehabilitation Program. This program is funded by the Community Development Block Grant Program (CDBG) awarded to the City of Lewisville by the U.S. Department of Housing and Urban Development (HUD). The program exists to provide assistance to low-to-moderate income homeowners by making essential repairs to, replacing, or initial installation of heating, ventilation, and air conditioning (HVAC) units and systems and performing electrical work related to and necessary for such HVAC unit or systems repairs, replacing, or initial installation.

Details of the selected homes' current HVAC systems can be found in "Document 01 – Homeowner Current Systems" and the BidTable in Bonfire.

CONTRACTOR QUALIFICATIONS

A consultant drafting a Scope of Work or contractor performing HVAC work on a project must meet the following qualifications at all times while work is being performed under this Program:

- Must be a registered contractor with the City of Lewisville's Building Services Division;
- Must have a valid HVAC license through the Texas Department of Licensing and Regulation;
- Must carry insurance that meets or exceeds the requirements outlined in the insurance requirements included in the Request for Bids (RFB).

BID BOND REQUIREMENTS

Bidders are required to submit a Bid Bond (with proper Power of Attorney) from a surety licensed to do business in the State of Texas, payable without recourse to the City of Lewisville, in an amount

Issued on April 11, 2026

not less than five (5%) percent of the total amount of the base bid submitted to insure that the successful bidder will enter into a contract and execute all necessary bonds within ten (10) days after notice of award of the contract to them. **This bid security must be uploaded to Bonfire or included in the bid envelope along with the bid sheet for the bidder to be considered responsive.**

The successful bidder will be required to furnish the following bonds from a surety licensed to do business in the State of Texas. These bonds, along with proper insurance papers, will be incorporated as part of the final contract documents and will remain in effect until the completion and acceptance of the project. Maintenance bonds shall be in effect based on their stated term after final acceptance of the project:

A bid bond equal to 5% of the project amount is to be included with the sealed bid; a payment bond and performance bond at the project amount and a maintenance bond for two years from the date of the final acceptance.

All bidders are notified that the qualification statement provided in the bid documents must be completed and submitted with the bid proposal. Failure to include this completed form with your bid may cause your bid to be disqualified as non-responsive.

The City is not responsible for any costs associated with the preparation of the bid from any vendor. Also, should a vendor bid an alternate; any test costs to prove equality of product will be at the expense of the vendor, not the City of Lewisville.

Each bidder is expected to inspect the site of the work and to inform himself regarding all local conditions. Ignorance of existing conditions of the site will not be a basis for any changes after the award of the bid.

Bids cannot be altered or amended after the submission deadline. Any interlineation, alteration, or erasure made before opening time must be initialed by the signee of the bid, guaranteeing authenticity.

In conformance with applicable statutes utilizing Federal Davis Bacon Wage Rates as adopted by the General Services Commission, the general prevailing wage rates in the locality in which the work is to be performed have been ascertained and such rate shall be the minimum paid for labor employed on this project; unless federal monies are used, in which case, specific wage decisions will be listed as part of the overall bid documents.

The City of Lewisville reserves the right to reject any and all bids, in whole or in part; to waive any informality in any bid. Award will be issued on the basis of lowest responsible bidder.

INSURANCE

Insurance shall be supplied by the awarded contractor within ten (10) days of notification of award, as detailed in this bid. Insurance must be approved by the City prior to the commencement of work and shall remain in effect throughout the entire duration of this project.

MISCELLANEOUS

All forms requiring either a signature or information to be filled in are to be returned with your bid. In addition, the language contained in the attached form entitled Purchase Order Terms and Conditions is made part of this request for bid through reference herein.

REQUEST FOR BIDS

Bids are to be submitted based on the specifications contained herein. Alternate bids will also be considered, provided the alternatives are clearly explained. All deviations from the specifications must be clearly identified and explained.

No telephone, email, or fax bids will be accepted. Bids may be accepted if delivered in person or by U.S. Postal Service, Federal Express, UPS, etc. or uploaded to Bonfire. The City is not responsible for missing, lost, or late delivery. Any RFB responses received after the time set for opening will be returned to the bidder unopened.

The preparation of the bid will be at the total expense of the bidder. There is no expressed or implied obligation for the City of Lewisville to reimburse responding bidders for any expense incurred in the preparation of bids in response to this request.

The City reserves the right to reject all bids, to consider alternatives, to waive any formalities and irregularities, and to re-solicit bids. In addition, during the evaluation period, the City may, where it may serve the City's best interest, request additional information or clarifications from bidders, or allow corrections of errors or omissions.

Each bidder shall guarantee and honor its response to these specifications for a period of ninety (90) days, or until the City enters a contract with one of the bidders, whichever occurs first.

The RFB will be available to interested parties on Bonfire or may be picked up in person at the Purchasing office.

All questions pertaining to this bid must be submitted in writing via Bonfire.

Bids may be uploaded to Bonfire at <https://cityoflewisville.bonfirehub.com/portal> or a sealed RFB consisting of one (1) hard copy and one (1) PDF file on a USB flash drive, clearly marked with the RFB title and date.

RFB: 26-74-B MINOR HOUSING REHABILITATION PROGRAM (HVAC REPAIR/REPLACE PROGRAM)

Issued on April 11, 2026

Delivery address:
City of Lewisville
Finance Administration – Purchasing Division
Attn: Janine Carpenter, Senior Buyer
151 W Church St
Lewisville, TX 75057

Regardless of the chosen delivery method, it is the sole responsibility of contractor to ensure their complete submittal is inside the Finance Administration Department – Purchasing Division before the required time. The City will not be responsible for, without limitation, any delays occasioned by third parties. Late or emailed submittals shall not be accepted, without exception.

PRE-BID

A pre-bid conference will be held at the date and time specified on Bonfire. While attendance of the pre-bid conference is not mandatory, it is recommended due to the nature of the project.

Homeowner Current HVAC Set Up			
Scope Identifier	Size of Cooling Area of Home	Current System(s)	Age of Home
A	1,893 Square Feet 4 Bedroom - 1 Story Home	Current Equipment Info (Manufacturer and Serial #): - Outdoor: Lennox 14ACX-036-230-14 - Furnace: Lennox MLI80UHO70E36B - Evaporator: Lennox CH33-43C-2F-3 - Thermostat: Digital Age of system: 14+ years Installed: 2013 (homeowner estimated) Most Recent Work: Unknown	2012
B	1,710 Square Feet 3 Bedroom - 1 Story Home	Current Equipment Info (Manufacturer and Serial #): - Outdoor: Amana ASZ130421AF - Air Handler: Goodman ARUF42C14AD - Evaporator: N/A - Thermostat: Honeywell Digital 2-Stage Age of system: 13+ years Installed: 20+ years ago (homeowner estimated) Most Recent Work: Minor repair and freeon added in 2025	1973
C	1,279 Square Feet 3 Bedroom - 1 Story Home	Current Equipment Info (Manufacturer and Serial #): - Outdoor: Trane 2TWR3030AI000AA - Furnace: First Company - Evaporator: N/A - Thermostat: Digital Age of system: 20+ years Installed: 10+ years ago (homeowner estimated) Most Recent Work: Replaced fan on outside unit in 2021	1970
D	1,143 Square Feet 2 Bedroom - 1 Story Home	Current Equipment Info (Manufacturer and Serial #): - Outdoor: Rheem I3PJL24AOI - Air Handler: Rheem RHSL-HM2417JA - Evaporator: N/A - Thermostat: Honeywell Digital Age of system: 15+ years Installed: 10+ years ago (homeowner estimated) Most Recent Work: Freeon added in 2025	1984
E	1,713 Square Feet 2 Bedroom - 2 Story Home	Current Equipment Info (Manufacturer and Serial #): - Outdoor: Missing tag - Air Handler: Trane TEM4A0CH48541SBA - Evaporator: N/A - Thermostat: Zoning Board and 2 Thermostats Age of system: 20+ years Installed: 20+ years ago (homeowner estimated) Most Recent Work: Freeon added 5+ years ago	2005

F	2,312 Square Feet 4 Bedroom - 1 Story Home	Current Equipment Info (Manufacturer and Serial #): - Outdoor: Heil N4A348GKB200 - Furnace: Ruud C-Cabinet 100k - Evaporator: ICP EDM4X48FA2 - Thermostat: Digital Age of system: 16+ years Installed: 13+ years ago (homeowner estimated) Most Recent Work: Fan replaced in 2025 and coolant added 2024	1974
G	1,369 Square Feet 3 Bedrooms - 2 Story Home	Current Equipment Info (Manufacturer and Serial #): - Outdoor: American Standard 2A7B0036A1000AA - Furnace: American Standard AUD080C936KI - Evaporator: Allstyle Coil ACL3644218 - Thermostat: Nest Age of system: 20+ years Installed: 10+ years ago (homeowner estimated) Most Recent Work: Freeon added 5+ years ago	1992
H	1,223 Square Feet 2 Bedrooms - 2 Story Home	Current Equipment Info (Manufacturer and Serial #): (Downstairs unit, upstairs unit 2 years old and not being replaced) - Outdoor: York 2-ton condensing unit - Air Handler: First Company - Evaporator: N/A - Thermostat: Digital Age of system: 35+ years Installed: 1985 Most Recent Work: Minor fixes in 2018	1985
I	1,016 Square Feet 1 Bedrooms - 2 Story Home	Current Equipment Info (Manufacturer and Serial #): - Outdoor: Goodman CK24-18 - Air Handler: Rheem 2-ton air handler and heat kit - Evaporator: N/A - Thermostat: Nest Age of system: 20+ years Installed: 15+ years ago (homeowner estimated) Most Recent Work: 3 years ago changed motor, 2 years ago added electric to outside unit and fan in attic	1980
J	1,688 Square Feet 4 Bedrooms - 1 Story Home	Current Equipment Info (Manufacturer and Serial #): - Outdoor: Carrier 24ABR342A0031010 - Air Handler: EPCO E44-168384 - Evaporator: N/A - Thermostat: Magic Star Age of system: 15+ years Installed: 2009 (homeowner estimated) Most Recent Work: Unclogged drainage pipe 3 years ago	1975
K	1,612 Square Feet 3 Bedrooms - 2 Story Home	Current Equipment Info (Manufacturer and Serial #): Both downstairs and upstairs units (both to be replaced) - Outdoor: Goodman GLBM24 and GLBN180 - Furnace: Goodman ARUFO24DDA-IA and ARUFO18-00A-1 - Evaporator: N/A - Thermostat: Digital Age of system: 18+ years Installed: 2008 (homeowner estimated) Most Recent Work: Minor repair and maintenance in 2025	1983

L	1,724 Square Feet 4 Bedrooms - 2 Story Home	<p>Current Equipment Info (Manufacturer and Serial #):</p> <ul style="list-style-type: none"> - Outdoor: Carrier CA16NAO48-B - Air Handler: Carrier FB4CNF048 - Evaporator: N/A - Thermostat: None <p>Age of system: Approximately 6 years Installed: 4 years ago (homeowner estimated) Most Recent Work: None</p>	1975
M	1,798 Square Feet 3 Bedrooms - 1 Story Home	<p>Current Equipment Info (Manufacturer and Serial #):</p> <ul style="list-style-type: none"> - Outdoor: TRANE TTRO48DI00A2 - Furnace: International Comfort FBF075F16G1 - Evaporator: ICP EPA48F19CI - Thermostat: Digital Honeywell <p>Age of system: 20+ years Installed: 12+ years ago (homeowner estimated) Most Recent Work: Maintenance in 2025</p>	2002
N	1,340 Square Feet 2 Bedrooms - 1 Story Home	<p>Current Equipment Info (Manufacturer and Serial #):</p> <ul style="list-style-type: none"> - Outdoor: American Standard 4A7B4036EI000AA - Furnace: American Standard AUD080R9V4K5 - Evaporator: American Standard 4TXFHD63A53HAAB - Thermostat: Digital Honeywell <p>Age of system: 16+ years Installed: 15+ years ago (homeowner estimated) Most Recent Work: Maintenance in 2025</p>	1975

PROPOSAL

City of Lewisville
Purchasing Office
151 West Church Street
P.O. Box 299002
Lewisville, Texas 75029-9002

Minor Housing Rehabilitation Program (HVAC Repair/Replace Program)

Proposal of _____
(hereinafter called Bidder), a corporation organized and existing under the laws of the State of _____, a partnership, or an individual doing business as _____

(Strike out inapplicable terms).

To the City of Lewisville, Texas (Owner)

The undersigned Bidder, in response to the Notice to Bidders for the construction of the above project and in conformity with the bidding documents; having examined the plans, specifications, related documents and the site of the proposed work; being familiar with all of the conditions relating to the construction of the proposed project, including the availability of materials and labor, hereby proposes to furnish all labor, materials, supplies, equipment, staking, testing, traffic control, superintendence, etc., for the construction of the project in accordance with the plans, specifications, and contract documents at the unit prices proposed herein.

The undersigned Bidder proposes, acknowledges and agrees to construct the entire project as shown on the plans, fully in accordance with the requirements of the plans, specifications, and the contract documents for the prices included in this Proposal and fully understands and agrees that the various items of material, labor and construction not specifically enumerated and provided for herein are considered subsidiary to the several items for which direct payment is specifically provided. Further, the undersigned agrees that one such subsidiary item is the protection, adjustment, maintenance, repair or replacement of all underground lines and services, whether shown on the plans or not, all to the full satisfaction of the City Engineer in a timely manner.

The undersigned Bidder agrees to begin work under the contract on or before the date specified in the written Notice to Proceed, and to fully complete the project within **120 calendar days**. It is specifically stated and understood that the entire construction, including clean up, shall be completed within the above stated time.

Proposal: 26-74-B Minor Housing Rehabilitation Program (HVAC Repair/Replace Program)

The undersigned Bidder has contacted, within 72 hours prior to bid opening, the Office of the City Engineer (972) 219-3490, and has determined that all Addenda are as follows:

Addendum No. 1 dated _____ (Signature)

Addendum No. 2 dated _____ (Signature)

Addendum No. 3 dated _____ (Signature)

The undersigned Bidder acknowledges that the Owner reserves the right to waive any informality and to reject any or all proposals.

The undersigned Bidder acknowledges and agrees that this Proposal shall be good and may not be withdrawn for 90 days from the date of bid opening.

The undersigned Bidder has shown unit prices and amounts and agrees that in the case of discrepancy, the unit prices shown in figures shall stand and that the amounts and total will be adjusted to correspond to the unit prices shown.

The undersigned Bidder agrees to execute the Agreement and furnish the required Performance Bond and Payment Bond within fifteen calendar days from the date of award of a contract by the City; and agrees that any delay in furnishing the signed Agreement and Bonds will result in liquidated damages being applied in accordance with Item 108.8.1. of the Standard Specifications.

The undersigned Bidder has attached and made a part of this Proposal a bid security in conformance with Item 102.5. of the Standard Specifications and in accordance with the Notice to Bidders.

A 5% contingency line item will be included with the resulting contract and purchase order for this project. The contingency shall be used at the City's discretion and only upon written approval from the City. The amount listed as a contingency is not an obligation for payment from the City. Any unused contingency is retained by the City and is not payable to the Contractor.

Submitted:

(Signature)

(Name - Typed or Printed)

(Title)

(Seal, if corporation)

(Firm Name)

(Address)

(City/County/State/Zip Code)

(Telephone Number/Include Area Code)

(Date)

(Attest)

CONTRACTOR'S QUALIFICATIONS

ALL BIDDERS ARE NOTIFIED THAT THE FOLLOWING QUALIFICATION STATEMENT MUST BE COMPLETED AND SUBMITTED WITH THE BID OR PROPOSAL.

The contractor shall show they have experience with similar projects that require working in confined areas in close proximity to many physical features (fences, utility poles, guy lines, gas lines and meters, sewer manholes, cleanouts, etc.) which requires the contractor to plan work efforts and equipment needs with these limitations in mind. The contractor shall submit a list of Public Works Projects successfully completed within the last five (5) years, including the names of supervisors and type of equipment used to perform this work.

BIDDER'S QUALIFICATION STATEMENT

Project: _____

Contractor: _____

Name: _____ Title: _____

Address: _____

Phone: _____ Email: _____

Type of Business:

Sole Proprietor Partnership Corporation Joint Venture Other _____

State and Date of Incorporation, Partnership, Ownership, Etc. _____

Principal Office Address: _____

Principal Office Contact & Phone: _____

Insurance:

Insurance Agency Name: _____

Insurance Agency Address: _____

Contact Name: _____ Phone: _____

Liability Insurance Provided and Limits of Coverage: _____

Workers Compensation Insurance Provider: _____

Surety Bonding Company (Performance & Payment: _____

Total Number of Employees to be Associated with this Job:

____ Managerial ____ Administrative ____ Professional

____ Skilled ____ Semi-Skilled ____ Other

Percentage of Work to be Done by Bidder's Employees (Based on Dollars Bid): _____

Type(s) of Work to be Done by Bidder's Employees (Examples: Concrete Paving, Structural Concrete, Water Lines, Sanitary Sewer Lines, Storm Pipe, Storm Inlets, Excavation, Lime, Bridge Fencing, etc.)

Access to Tools and Equipment: Percent Owned: _____ Percent Rented: _____

Number of Years in Business as a Contractor on Above Types of Work: _____

Sub-Contractor Information (use additional sheets, if needed.):

Name: _____ Phone: _____

Address: _____

Type of Work _____

List the most current completed projects like the type of work bid (use additional sheets, if necessary.)

Project: _____

Owner/Agency: _____

Year Built: _____ Contract Price: _____

Equipment Used: _____

Contact Name: _____ Title: _____

Email: _____ Phone: _____

Project: _____

Owner/Agency: _____

Year Built: _____ Contract Price: _____

Equipment Used: _____

Contact Name: _____ Title: _____

Email: _____ Phone: _____

Project: _____

Owner/Agency: _____

Year Built: _____ Contract Price: _____

Equipment Used: _____

Contact Name: _____ Title: _____

Email: _____ Phone: _____

Trade References (attach additional sheets if needed):

Company: _____ Contact: _____

Address: _____

Email: _____ Phone: _____

Company: _____ Contact: _____

Address: _____

Email: _____ Phone: _____

Company: _____ Contact: _____

Address: _____

Email: _____ Phone: _____

Bank References (attach additional sheets if needed):

Institution: _____ Contact Name: _____

Address: _____ Phone: _____

Financial statements are not required as part of this bid package, however a balance sheet and income statement from the previous fiscal year shall be required from the apparent low bidder to be reviewed and approved by the Finance Director prior to contract award.

Claims and Suits (If the answer to any of the questions is yes, please attach details):

Has your organization ever failed to complete any work awarded to it? Yes No

Are there any judgments, claims, arbitration proceedings, or suits pending or outstanding against your organization or its officers? Yes No

Has your organization filed any lawsuits or requested arbitration regarding construction contracts within the last five years? Yes No

Within the last five (5) years, has any officer or principal of your organization ever been an officer or principal of another organization when it failed to complete a construction contract?
 Yes No

PROPOSED SUBCONTRACT BREAKDOWN

1. Subcontractor	_____
Address	_____
Phone #	_____
Description of Work	_____
2. Subcontractor	_____
Address	_____
Phone #	_____
Description of Work	_____
3. Subcontractor	_____
Address	_____
Phone #	_____
Description of Work	_____
4. Subcontractor	_____
Address	_____
Phone #	_____
Description of Work	_____

Reference is made to Item 21 on Page SS-11

LIST OF SUPPLIERS

1.	Item Supplied	_____
	Supplier	_____
	Address	_____
	Phone #	_____
2.	Item Supplied	_____
	Supplier	_____
	Address	_____
	Phone #	_____
3.	Item Supplied	_____
	Supplier	_____
	Address	_____
	Phone #	_____
4.	Item Supplied	_____
	Supplier	_____
	Address	_____
	Phone #	_____

PERFORMANCE BOND

**STATE OF TEXAS
COUNTY OF DENTON**

KNOW ALL MEN BY THESE PRESENTS: That _____ of the City of _____, County of _____, and State of _____, as Principal, and _____ authorized under the laws of the State of Texas to act as Surety on bonds for Principal, are held and firmly bound unto the City of Lewisville (Owner), in the penal sum of _____ Dollars (\$_____) for the payment whereof, the said Principal and Surety bind themselves, and their heirs, administrators, executors, successors and assigns, jointly and severally, by these presents:

WHEREAS, the Principal has entered into a certain written contract (Contract) with the Owner, dated the ____ day of _____, 20____ to construct:

26-74-B Minor Housing Rehabilitation Program (HVAC Repair/Replace Program)

which Contract is hereby referred to and made a part hereof as fully and to the same extent as if copied at length herein.

NOW, THEREFORE, THE CONDITION OF THIS OBLIGATION IS SUCH, that if the said Principal shall faithfully perform said Contract and shall in all respects duly and faithfully observe and perform all and singular the covenants, conditions and agreements in and by said Contract agreed and covenanted by the Principal to be observed and performed, and according to the true intent and meaning of said Contract and the Plans and Specifications hereto annexed, then this obligation shall be void; otherwise to remain in full force and effect;

PROVIDED, HOWEVER, that this bond is executed pursuant to the provisions of Chapter 2253 of the Texas Government Code as amended and all liabilities on this bond shall be determined in accordance with the provisions of said Chapter to the same extent as if it were copied at length herein.

Surety, for value received, stipulates and agrees that no change, extension of time, alteration or addition to the terms of the contract, or to the work performed thereunder, or the plans, specifications, or drawings accompanying the same, shall in anyway affect its obligation on this bond, and it does hereby waive notice of any such change, extension of time, alteration or addition to the terms of the contract, or to the work to be performed thereunder.

IN WITNESS WHEREOF, the said Principal and Surety have signed and sealed this instrument this _____ day of _____, 20__.

Principal

Surety

By:

By

Title:

Title

Address:

Address:

The name and address of the Resident Agent of Surety is:

PAYMENT BOND

**STATE OF TEXAS
COUNTY OF DENTON**

KNOW ALL MEN BY THESE PRESENTS: That _____ of the City of _____, County of _____, and State of _____, as Principal, and _____ authorized under the laws of the State of Texas to act as Surety on bonds for Principal, are held and firmly bound unto the City of Lewisville (Owner), in the penal sum of _____ Dollars (\$_____) for the payment whereof, the said Principal and Surety bind themselves and their heirs, administrators, executors, successors and assigns, jointly and severally, by these presents:

WHEREAS, the Principal has entered into a certain written contract (Contract) with the Owner, dated the _____ day of _____, 20__ to construct:

26-74-B Minor Housing Rehabilitation Program (HVAC Repair/Replace Program)

which Contract is hereby referred to and made a part hereof as fully and to the same extent as if copied at length herein.

NOW, THEREFORE, THE CONDITION OF THIS OBLIGATION IS SUCH, that if the said Principal shall pay all claimants supplying labor and material to him or a subcontractor in the prosecution of the work provided for in said Contract, then, this obligation shall be void; otherwise to remain in full force and effect;

PROVIDED, HOWEVER, that this bond is executed pursuant to the provisions of Chapter 2253 of the Texas Government Code as amended and all liabilities on this bond shall be determined in accordance with the provisions of said Chapter to the same extent as if it were copied at length herein.

Surety, for value received, stipulates and agrees that no change, extension of time, alteration or addition to the terms of the contract, or to the work performed thereunder, or the plans, specifications or drawings accompanying the same, shall in anyway affect its obligation on this bond, and it does hereby waive notice of any such change, extension of time, alteration or addition to the terms of the contract, or to the work to be performed thereunder.

IN WITNESS WHEREOF, the said Principal and Surety have signed and sealed this instrument this _____ day of _____, 20__.

Principal

Surety

By:

By

Title:

Title

Address:

Address:

The name and address of the Resident Agent of Surety is:

MAINTENANCE BOND

Bond No. _____

KNOW ALL MEN BY THESE PRESENTS:

That we, _____
(hereinafter called **Principal**), and _____, a corporation organized under the laws of the State of _____ and authorized to do a surety business in the State of Texas, (hereinafter called **Surety**), are held and firmly bound unto the City of Lewisville, Texas (hereinafter called the **City**) in the full and just sum of _____, lawful money of the United States of America, for the payment of which sum, well and truly to be made, we bind ourselves, our heirs, executors, administrators, successors and assigns, jointly and severally, firmly by these presents.

WHEREAS, said **Principal** has performed _____
improvements, which have been or are about to be completed and accepted by the **City** for the project known as:

26-74-B Minor Housing Rehabilitation Program (HVAC Repair/Replace Program)

AND WHEREAS, it is required that the **Principal** should guarantee the project from defects caused by faulty or defective materials, workmanship, or design for a period of two years from and after the date of acceptance of the completed project by the **City**.

NOW, THEREFORE, if the **Principal** shall for a period of two years from and after the date of acceptance of the completed project by the **City** replace any and all defects arising in said work whether resulting from faulty or defective materials, workmanship, or design, then the above obligation shall be null and void; otherwise the obligation shall remain in full force and effect for two years from the date of acceptance of the completed project by the **City**.

The **City** shall notify the **Principal** in writing of any defects for which the **Principal** is responsible and shall specify in said notice a reasonable time within which the **Principal** shall have to correct said defects. If the **Principal** fails to correct said defects within the time specified in said notice, the **City**, in its discretion, may permit the **Surety** to correct said defects. If the **City** allows the **Surety** to

correct said defects, the **Surety** shall have sixty (60) days thereafter within which to take such action as it deems necessary to insure performance of the **Principal's** obligation.

If such defects are not corrected after the time period specified in the notice or after the expiration of the sixty (60) day time period, whichever is applicable, the **City** shall have the right to correct the defects, and the **Principal** and **Surety**, jointly and severally, shall pay all costs and expenses incurred by the **City** in correcting the defects, including, but not limited to, the engineer, legal and other costs, together with any damages either direct or consequential, which the **City** sustains, or may sustain, on account of the **Principal's** failure to correct the defects. In addition, the **City** shall have the right to contract for the correction of said defects and, upon acceptance of a bid in accordance with the **City's** normal bidding process, the **Principal** and **Surety** shall become immediately liable for the amount of the bid. In the event that the **City** commences legal proceedings for the collection thereof, interest shall accrue on said amount at the rate of six (6) percent per annum, beginning at the commencement of said legal proceedings.

If the City commences suit for collection of any sums due hereunder, the **Principal** and **Surety**, jointly and severally, agree to pay all costs and expenses incurred by the **City**, including, but not limited to, attorney's fees.

IN WITNESS WHEREOF, the parties have caused this instrument to be signed and sealed by their respective authorized officers this _____ day of _____ 20__.

Principal: _____

Surety: _____

By: _____

By: _____

_____, *Attorney-in-Fact*

Address: _____

Address: _____

Witness as to Principal

**CITY OF LEWISVILLE
PURCHASING DIVISION**

BOND REQUIREMENTS AND RETAINAGE

BONDS

The successful bidder will be required to furnish the following bonds from a surety licensed to do business in the State of Texas. These bonds, along with proper insurance papers, will be incorporated as part of the final contract documents and will remain in effect until the completion and acceptance of the project. Maintenance bonds shall be in effect based on their stated term after final acceptance of the project:

Project amount \$10,001 to \$24,999 – a payment bond at the project amount and a maintenance bond for one year from the date of final payment.

Project amount \$25,000 to \$99,999 – a payment bond at the project amount and a maintenance bond for two years from the date of the final payment.

Project amount \$100,000 and greater – a signed, fully executed bid bond equal to five percent (5%) of the project amount is to be included with the sealed bid; a payment bond and performance bond at the project amount and a maintenance bond for two years from the date of the final payment.

RETAINAGE

Retainage will be based on the following: Fifteen percent (15%) retainage for contracts up to \$25,000; ten percent (10%) retainage for contracts more than \$25,000 and less than \$400,000; five percent (5%) retainage for contracts in excess of \$400,000.

**PURCHASE ORDER
TERMS & CONDITIONS**

Seller and Buyer agree to comply with the following terms and conditions. These Terms and Conditions along with the purchase order shall constitute a contract between the Seller and Buyer upon the Seller issuing an invoice and/or providing any of the goods and services described in the purchase order. In the event of a conflict between these Terms and Conditions and a separate written agreement between the Seller and Buyer, the terms of the separate written agreement shall prevail.

1. SELLER TO PACKAGE GOODS: Seller will package goods in accordance with good commercial practice. Each shipping container shall be clearly and permanently packed as follows: (a) Seller's name and address; (b) Consignee's name, address and purchase order or purchase order release number and the supply agreement number if applicable; (c) Container number and total number of containers, e.g. box 1 of 4 boxes; and (d) the number of the container bearing the packing slip. Seller shall bear cost of packaging unless otherwise provided. Goods shall be suitably packed to secure lowest transportation costs and to conform with requirements of common carriers and any applicable specifications. Buyer's count or weight shall be final and conclusive on shipments not accompanied by packing lists.

2. SHIPMENT UNDER RESERVATION PROHIBITED: Seller is not authorized to ship the goods under reservation and no tender of a bill of lading will operate as a tender of goods.

3. TITLE AND RISK OF LOSS: The title and risk of loss of the goods shall not pass to Buyer until Buyer actually receives and takes possession of the goods at the point or points of delivery.

4. DELIVERY TERMS AND TRANSPORTATION CHARGES: F.O.B. Inside Delivery, Municipal Facility, Lewisville, Texas, and shall include all delivery and packaging costs. The Buyer assumes no liability for goods delivered in damaged or unacceptable condition. The Seller shall handle all claims with carriers, and in case of damaged goods, shall ship replacement goods immediately upon notification by Seller of damage.

5. NO REPLACEMENT OF DEFECTIVE TENDER: Every tender or delivery of goods must fully comply with all provisions of this contract as to time of delivery, quality and the like. If a tender is made which does not fully conform, this shall constitute a breach and Seller shall not have the right to substitute a conforming tender provided, where the time for performance has not yet expired, the Seller may notify Buyer of his intention to cure and may then make a conforming tender within the contract time but not afterward.

6. PLACE OF DELIVERY: The place of delivery shall be that set forth on the purchase order. Any change thereto shall be effected by modification as provided for in Clause 20, "Modifications", hereof. The terms of this contract are "no arrival, no sale".

7. INVOICES AND PAYMENTS: (a) Seller shall submit separate invoices on each purchase order after each delivery. Invoices shall indicate the purchase order number, shall be itemized and transportation charges, if any, shall be listed separately. A copy of the bill of lading, and the freight weigh bill when applicable, should be attached to the invoice. Mail to: City of Lewisville Accounts Payable, PO Box 299002 Lewisville, Texas 75029-9002. Payments shall be made thirty days after the goods are delivered to the Buyer, or a correct invoice is received, whichever is later. Suppliers should keep the Accounts Payable Office advised of any changes in remittance addresses. (b) Buyer's obligation is payable only and solely from funds available for the purpose of the purchase. Lack of funds shall render this contract null and void to the extent funds are not available and any delivered but unpaid for goods will be returned to Seller by Buyer. (c) Do not include Federal Excise, State or City Sales Tax. Buyer shall furnish tax exemption certificate, if required.

8. GRATUITIES: The Buyer may, by written notice to the Seller, cancel this contract without liability to Seller if it is determined by Buyer that gratuities, in the form of entertainment, gifts, or otherwise, were offered or given by the Seller, or any agent, or representative of the Seller, to any officer or employee of the City of Lewisville with a view toward securing a contract or securing favorable treatment with respect to the awarding or amending or the making or any determinations with respect to the performing of such a contract. In the event this contract is cancelled by Buyer pursuant to this provision, Buyer shall be entitled, in addition to any other rights and remedies, to recover or withhold the amount of the cost incurred by Seller in providing such gratuities.

9. SPECIAL TOOLS AND TEST EQUIPMENT: If the price stated on the face hereof includes the cost of any special tooling or special test equipment fabricated or required by Seller for the purpose of filling this order, such special tooling equipment and any process sheets related thereto shall become the property of the Buyer and to the extent feasible shall be identified by the Seller as such.

10. WARRANTY PRICE: (a) The price to be paid by the Buyer shall be that contained in Seller's bid which Seller warrants to be no higher than Seller's current prices on orders by others for products of the kind and specification covered by this contract for similar quantities under similar or like conditions and methods of purchase. In the event Seller breaches this warranty, the prices of the items shall be reduced to the Seller's current prices on orders by others, or in the alternative, Buyer may cancel this contract without liability to Seller for breach or Seller's actual expense. (b) The Seller warrants that no person or selling agency has been employed or retained to solicit or secure this contract upon an agreement or understanding for commission, percentage, brokerage, or contingent fee excepting bona fide employees of bona fide established commercial or selling agencies maintained by the Seller for the purpose of securing business. For breach of violation of this warranty, the Buyer shall have the right in addition to any other right or rights to cancel this contract without liability and to deduct from the contract price, or otherwise recover the full amount of such commission, percentage, brokerage or contingent fee.

11. WARRANTY PRODUCTS: Seller shall not limit or exclude any implied warranties and any attempt to do so shall render this contract voidable at the option of the Buyer. Seller warrants that the goods furnished will conform to the specifications, drawings and descriptions listed in the bid invitation and to the sample(s) furnished by Seller, if any. In the event of a conflict between the specifications, drawings and descriptions, the specifications shall govern.

12. SAFETY WARRANTY: Seller warrants that the product sold to Buyer shall conform to the standards promulgated by the U. S. Department of Labor under the Occupational Safety and Health Act of 1970. In the event the product does not conform to OSHA standards, Buyer may return the product for correction or replacement at the Seller's expense. In the event Seller fails to make the appropriate correction within a reasonable time, correction made by Buyer will be at Seller's expense.

13. NO WARRANTY BY BUYER AGAINST INFRINGEMENTS: As part of this contract for sale Seller agrees to ascertain whether goods manufactured in accordance with the specifications attached to this contract will give rise to the rightful claim of any third person by way of infringement or the like. Buyer makes no warranty that the production of goods according to the specification will not give rise to such a claim, and in no event shall Buyer be liable to Seller for indemnification in the event that Seller is sued on the grounds of infringement or the like. If seller is of the opinion that an infringement or the like will result, he will notify Buyer to this effect in writing within two weeks after the signing of this contract. If Buyer does not receive notice and is subsequently held liable for the infringement of the like, Seller will save Buyer harmless. If Seller in good faith ascertains that production of the goods in accordance with the specifications will result in infringement or the like, this contract shall be null and void except that Buyer will pay Seller the reasonable cost of his search as to infringements.

14. RIGHT OF INSPECTION: Buyer shall have the right to inspect the goods at delivery before accepting them.

15. CANCELLATION: Buyer shall have the right to cancel for default all or any part of the undelivered portion of this order if Seller breaches any of the terms hereof including warranties of Seller or if the Seller becomes insolvent or commits acts of bankruptcy. Such right of cancellation is in addition to and not in lieu of any other remedies which Buyer may have in law or equity.

16. TERMINATION: The performance of work under this order may be terminated in whole or in part by the Buyer in accordance with this provision. Termination of work hereunder shall be effected by the delivery to the Seller of a "Notice of Termination" specifying the extent to which performance of work under the order is terminated and the date upon which such termination becomes effective. Such right of termination is in addition to and not in lieu of rights of Buyer set forth in Clause 15, herein.

17. FORCE MAJEURE: If by reason of Force Majeure, either party hereto shall be rendered unable wholly or in part to carry out its obligations under this contract then such party shall give notice and full particulars of Force Majeure in writing to the other party within a reasonable time after occurrence of the event or cause relied upon, and the

obligation of the party giving such notice, so far as it is affected by such Force Majeure, shall be suspended during the continuance of the inability then claimed, except as hereinafter provided, but for no longer period, and such party shall endeavor to remove or overcome such inability with all reasonable dispatch. The term Force Majeure as employed herein, shall mean acts of God, strikes, lockouts, or other industrial disturbances, act of public enemy, orders of any kind of government of the United States or the State of Texas or any civil military authority, insurrections, riots, epidemics, landslides, lightning, earthquakes, fires, hurricanes, storms, floods, washouts, droughts, arrests, restraint of government and people, civil disturbances, explosions, breakage or accidents to machinery, pipelines or canals, or other causes not reasonably within the control of the party claiming such inability.

18. ASSIGNMENT DELEGATION: No right or interest in this contract shall be assigned or delegation of any obligation made by Seller without the written permission of the Buyer. Any attempted assignment or delegation by Seller shall be wholly void and totally ineffective for all purposes unless made in conformity with this paragraph.

19. WAIVER: No claim or right arising out of a breach of this contract can be discharged in whole or in part by a waiver or renunciation of the claim or right unless the waiver or renunciation is supported by consideration and is in writing signed by the aggrieved.

20. MODIFICATIONS: This contract may be modified or rescinded only by a writing signed by both of the parties or their duly authorized agents. This shall include any change orders.

21. INTERPRETATION PAROLE EVIDENCE: This writing is intended by the parties as a final expression of their agreement and is intended also as a complete and exclusive statement of the terms of their agreement. No course of prior dealings between the parties and no usage of the trade shall be relevant to supplement or explain any term used in this contract. Acceptance or acquiescence in a course of performance rendered under this contract shall not be relevant to determine the meaning of this contract even though the accepting or acquiescing party has knowledge of the performance and opportunity for objection. Whenever a term defined by the Uniform Commercial Code is used in this contract, the definition contained in the Code is to control.

22. APPLICABLE LAW: This contract shall be governed by the Uniform Commercial Code. Wherever the term "Uniform Commercial Code" is used, it shall be construed as meaning the Uniform Commercial Code as adopted in the State of Texas as effective and in force on the date of this contract.

23. ADVERTISING: Seller shall not advertise or publish, without Buyer's prior consent, the fact that Buyer has entered into this contract, except to the extent necessary to comply with proper requests for information from an authorized representative of the federal, state or local government.

24. RIGHT TO ASSURANCE: Whenever one party to this contract in good faith has reason to question the other party's intent to perform he may demand that the other party give written assurance of his intent to perform. In the event that a demand is made and no assurance is given within five (5) days, the demanding party may treat this failure as an anticipatory repudiation of the contract.

25. VENUE: Both parties agree that venue for any litigation arising from this contract shall lie in Denton County, Texas.

26. DISCLOSURE: Pursuant to Chapter 176 of the Texas Local Government Code, a person or agent of a person who contracts or seeks to contract with the City of Lewisville must complete a conflict of interest questionnaire if the person or agent has an affiliation or business relationship that might cause a conflict of interest with the City. The conflict of interest questionnaire, which is available online at ethics.state.tx.us, must be filed with the City Secretary of the City of Lewisville no later than the seventh business day after the person or agent begins contract discussions or negotiations with the City of Lewisville or submits to the City of Lewisville an application, response to a request for proposal or bid, correspondence, or another writing related to a potential agreement with the City of Lewisville. An updated conflict of interest questionnaire must be filed in accordance with Chapter 176 of the Local Government Code

Seller should consult with legal counsel if you have questions regarding its compliance with the requirements of Chapter 176. It is the responsibility of each person or agent who is contracting or seeking to contract with the City of Lewisville to comply with the filing requirements of Chapter 176.

27. INDEPENDENT CONTRACTOR: Seller shall be considered an independent contractor and not an agent, servant, employee, or representative of Buyer in the performance of the work. No term or provision herein or act of the Seller shall be construed as changing that status.

28. TERMINATION FOR DEFAULT: Buyer reserves the right to enforce the performance of any Purchase Order in any manner prescribed by law or deemed to be in the best interest of Buyer in the event of breach or default. The Buyer reserves the right to terminate any purchase order and/or agreement with the Seller in the event the Seller fails to: (a) meet delivery schedules, or (b) otherwise perform in accordance with these terms and conditions.

29. PROTESTS: All protests regarding the solicitation process must be submitted in written form to the Purchasing Manager within five (5) working days following the opening of bids/proposals. This includes all protests relating to legal advertisements, deadlines, bid/proposal openings, and all other related procedures under the Local Government Code

Post-award protests must be submitted in written form to the City Manager within five (5) working days after award. The protest must include, at a minimum, the name of protester, bid/proposal number or description of goods or services, and a statement of grounds for protest.

30. INDEMNIFICATION: SELLER AGREES TO DEFEND, INDEMNIFY AND HOLD BUYER, ITS OFFICERS, AGENTS AND EMPLOYEES, HARMLESS AGAINST ANY AND ALL CLAIMS, LAWSUITS, JUDGMENTS, COSTS AND EXPENSES FOR PERSONAL INJURY (INCLUDING DEATH), PROPERTY DAMAGE OR OTHER HARM FOR WHICH RECOVERY OF DAMAGES IS SOUGHT, SUFFERED BY ANY PERSON OR PERSONS, THAT MAY ARISE OUT OF OR BE OCCASIONED BY SELLER'S BREACH OF ANY OF THESE TERMS AND CONDITIONS OR BY ANY NEGLIGENT OR STRICTLY LIABLE ACT OR OMISSION, INTENTIONAL TORT, INTELLECTUAL PROPERTY INFRINGEMENT, OR FAILURE TO PAY A SUBCONTRACTOR OR SUPPLIER COMMITTED BY SELLER, ITS OFFICERS, AGENTS, EMPLOYEES OR SUBCONTRACTORS, IN THE PERFORMANCE OF THIS CONTRACT; EXCEPT THAT THE INDEMNITY PROVIDED FOR IN THIS PARAGRAPH SHALL NOT APPLY TO ANY LIABILITY RESULTING FROM THE SOLE NEGLIGENCE OR FAULT OF BUYER, ITS OFFICERS, AGENTS, EMPLOYEES OR SEPARATE CONTRACTORS, AND IN THE EVENT OF JOINT AND CONCURRING NEGLIGENCE OR FAULT OF THE SELLER AND BUYER, RESPONSIBILITY AND INDEMNITY, IF ANY, SHALL BE APPORTIONED IN ACCORDANCE WITH THE LAW OF THE STATE OF TEXAS, WITHOUT WAIVING ANY GOVERNMENTAL IMMUNITY AVAILABLE TO BUYER UNDER TEXAS LAW AND WITHOUT WAIVING ANY DEFENSES OF THE PARTIES UNDER TEXAS LAW. THE PROVISIONS OF THIS PARAGRAPH ARE SOLELY FOR THE BENEFIT OF THE PARTIES HERETO AND NOT INTENDED TO CREATE OR GRANT ANY RIGHTS, CONTRACTUAL OR OTHERWISE, TO ANY OTHER PERSON OR ENTITY.

31. SEVERABILITY: In case any one or more of the provisions contained in these Terms and Conditions shall for any reason be held to be invalid, illegal, or unenforceable in any respect, such invalidity, illegality, or unenforceability shall not affect any other provision thereof, and these Terms and Conditions shall be construed as if such invalid, illegal, or unenforceable provision had never been contained herein.

32. IMMIGRATION REFORM AND CONTROL ACT (8 U.S.C 1324a): The Buyer supports the Immigration Reform and Control Act (IRCA), which is a comprehensive scheme prohibiting the employment of unauthorized aliens in the United States. The Seller and its subcontractors shall at all times during the term of the contract with the Buyer comply with the requirements of IRCA and shall notify the Buyer within fifteen (15) working days of receiving notice of a violation of IRCA. The Seller also warrants that it has not had an IRCA violation within the last five (5) years. The Buyer may terminate a contract with the Seller if the Buyer determines that (a) the Seller or its subcontractors have been untruthful regarding IRCA violations in the preceding five (5) years or (b) the Seller or its subcontractors fail to timely notify the Buyer of an IRCA violation.

33. ADA COMPLIANCE: All goods and services provided to the Buyer must be compliant with the Americans with Disabilities Act and any amendments thereto (the "ADA") and all regulations promulgated pursuant to the ADA. Seller will be required to certify compliance, if required under the law or otherwise required by the Buyer.

34. PROTECTION OF RESIDENT WORKERS: The Buyer actively supports the Immigration and Nationality Act (INA), which includes provisions addressing employment eligibility, employment verification, and nondiscrimination. Under the INA, employers may hire only persons who may legally work in the United States (i.e., citizens and nationals of the U.S.) and aliens authorized to work in the U.S. The employer must verify the identity and employment eligibility of anyone to be hired, which includes completing the Employment Eligibility Verification Form (I-9). The Seller shall establish appropriate procedures and controls so no services under the contract will be performed by any worker who is not legally eligible to perform such services or employment. The Buyer reserves the right to audit Seller's employment records to verify the existence of a completed Employment Eligibility Verification Form (I-9) for every worker performing services under the contract. The audit will be at the Buyer's expense.

35. TEXAS GOVERNMENT CODE CHAPTER 2252. Pursuant to Texas Government Code Chapter 2252, Subchapter F, Consultant affirms, by entering into this Agreement, that it is not identified on a list created by the Texas Comptroller of Public Accounts as a company known to have contracts with or provide supplies or services to Iran, Sudan, or a foreign terrorist organization.

36. TEXAS GOVERNMENT CODE CHAPTER 2271. Pursuant to Texas Government Code Chapter 2271, Consultant affirms that execution of this Agreement serves as written verification that Consultant: (1) does not boycott Israel, as defined by Texas Government Code Section 808.001; and (2) will not boycott Israel during the term of the Agreement. This section shall not apply if Consultant employs fewer than ten (10) full-time employees, or if the funds to be paid wholly or partly from public funds of the City under this Agreement are less than \$100,000.00.

37. TEXAS GOVERNMENT CODE CHAPTER 2274. Pursuant to Texas Government Code Chapter 2274, Consultant verifies the following:

- A. Consultant: (1) does not boycott energy companies, as defined by Texas Government Code Section 809.001; and (2) will not boycott energy companies during the term of this Agreement.
- B. Consultant: (1) does not have a practice, policy, guidance, or directive that discriminates against a firearm entity or firearm trade association, as those terms are defined in that chapter; and (ii) will not discriminate during the term of this Agreement against a firearm entity or firearm trade association.

This section shall not apply if Consultant employs fewer than ten (10) full-time employees, if the funds to be paid wholly or partly from public funds of the City under this Agreement are less than \$100,000.00, or if this Agreement is otherwise exempted from the requirements of Texas Government Code Chapter 2274.

**CITY OF LEWISVILLE
PURCHASING DIVISION**

INSTRUCTIONS TO BIDDERS

INSTRUCTIONS: These instructions apply to all bids and become a part of the terms and conditions of any bid submitted.

BIDS must not be faxed, but are to be submitted to the City in one of the following manners:

- A. **Electronic Receipt:** Bidders are encouraged to submit bids to the City through Bonfire. The City is a member of this electronic bidding platform and the submittal of bids to the City is at no cost to the bidder. The internet site is www.gobonfire.com.

or

- B. **Paper Bid Receipt:** Paper bids may be submitted to the City. Bidders are to submit the original and one PDF copy of the bid on a flash drive in a sealed envelope to the Purchasing Division prior to response due date/time. The sealed envelope is to be marked on the outside with the bidder's name, address, the bid invitation number, and closing date recorded on the bottom left corner of the envelope.

Address to:

City of Lewisville
Finance Administration - Purchasing Division
151 W. Church St.
Lewisville, Texas 75057

Sealed bids must be submitted in sufficient time as to be received and time stamped at the above location on or before the published bid date and time shown on the bid invitation. Bids received after submission deadline shall be returned unopened and will be considered void and unacceptable. The City of Lewisville is not responsible for lateness of mail carrier, etc.

BID: The bidder should quote its lowest and best price, F.O.B. destination on each item bid. If delivery and shipping quantities affect unit bid price, multiple bids may be made so as to indicate "price break" quantities in order for the City to determine maximum economic benefits. Pricing for paper bids shall be entered on the Bid Sheet in ink or typewritten. Totals shall be entered in the "Total Price" column of the Bid Sheet. In all cases of discrepancy between unit price and extended price, the unit price will be presumed to be correct.

MAKE-MODEL Items must be the best and latest model available of the type specified. If the bid invitation indicates a specific brand of product, the brand listed is deemed to be descriptive and not restrictive and is used to indicate the type and quality level desired for comparison purposes. Bidders may offer an approved equal to the brand listed, unless otherwise noted. The City shall make the final determination as to the brand offered being an approved equal to the brand listed. A Complete catalog or brochure showing in detail the item offered must accompany the bid.

SPLIT-AWARD: Bidders may furnish pricing for all or any portion of the bid invitation. Unless the bidder specifies otherwise in his bid, the City may award the contract for any item or group of items shown on the bid invitation.

BID FORMS: Bids submitted on other than City forms, whether electronic or paper, or with different terms or provisions may not be considered as responsive bids.

Bids must be held firm for ninety (90) days to allow for evaluation unless otherwise noted in the bid document.

F.O.B./DAMAGE: Quotations shall be bid F.O.B. Inside Delivery, Municipal Facility, Lewisville, Texas, and shall include all delivery and packaging costs. The City of Lewisville assumes no liability for goods delivered in damaged or unacceptable condition. The successful bidder shall handle all claims with carriers, and in case of damaged goods, shall ship replacement goods immediately upon notification by the City of damage.

INVOICES: Invoices must be submitted by the successful bidder in duplicate to the City of Lewisville Accounts Payable, P O Box 299002, Lewisville, TX 75029-9002 or may be emailed to: accountspayable_col@cityoflewisville.com.

TAXES: The City of Lewisville is exempt from Federal Manufacturer's Excise, and State Sales taxes. TAX MUST NOT BE INCLUDED IN BID. Tax exemption certificates will be executed by the City and furnished upon request.

PRICING: Bids should be firm. If the bidder, however, believes it necessary to base its price on price adjustment, such a bid may be considered, but only as an alternate bid.

PAYMENT TERMS: Payment terms are net 30 days after the goods are provided or services are completed, as required, or a correct invoice is received, whichever is later.

DELIVERY PROMISE - PENALTIES: Bids MUST show the number of calendar days required to place the materials in the possession of the City. DO NOT quote shipping dates. Consistent failure of a bidder to meet his delivery promises without valid reason may be cause for removal from the Bidder's List. When Delivery delays can be foreseen, the bidder shall give prior notice to the Purchasing Division which shall have the right to extend the delivery due date if reasons for delay appear acceptable. Default in promised delivery, without acceptable reasons, or failure to meet specifications, authorizes the Purchasing Division to purchase the goods elsewhere, and charge any increase in cost and handling to the defaulting bidder.

PACKAGING: Unless otherwise indicated, items will be new, unused, and in first class condition in containers suitable for damage-free delivery and storage.

CORRESPONDENCE: The bid number must appear on ALL correspondence, inquiries, etc. pertaining to the bid.

DELIVERY TIMES: Deliveries will be acceptable only during normal working hours at the designated City Municipal Facility.

PATENT RIGHTS: The Vendor agrees to indemnify and hold the City harmless from any and all claims involving patent right infringement or copyrights on goods supplied.

EVALUATION: Response to the specification in this bid is of primary importance in determining the lowest responsible bid.

BID AWARD: Bids will be awarded either on Lowest Responsible Bid or Best Value. The Criteria used to determine Best Value is as follows:

- Purchase Price
- The reputation of the bidder and of the bidder's goods and service
- The quality of the bidder's goods or services
- The extent to which the goods or services meet the municipality's needs.
- The bidder's past relationship with the municipality.
- The impact on the ability of the city to comply with laws and rules relating to contracting with historically underutilized businesses and non-profit organizations employing persons with disabilities.

The total long-term cost to the city to acquire the bidders good or services (Life Cycle Costing).

Any other relevant factors that a private business would consider in selecting a bidder.

FUNDING: The City of Lewisville is a home-rule municipal government operated and funded on an October 1 to September 30 Fiscal Year; accordingly, the City reserves the right to terminate, without liability to the City any contract for which funding is not available.

RESERVATIONS: The City expressly reserves the right to:

- A. Waive as an informality, minor deviations from specifications.
- B. Waive any defect, irregularity or informality in any bid or bidding procedure.
- C. Reject or cancel any or all bids.
- D. Reissue a bid invitation.
- E. Extend the bid opening time and date.
- F. Procure any item by other means.
- G. Increase or decrease the quantity specified in the bid invitation, unless the Bidder specifies otherwise.
- H. Consider and accept an alternate bid as provided herein when most advantageous
- I. to the City.

ASSIGNMENT: The successful bidder shall not sell, assign, transfer or convey this contract in whole or in part, without the prior written consent of the City.

AUDIT: The City of Lewisville reserves the right to audit the records and performance of the successful bidder during the term of the contract and for three years after the contract is completed.

PROTESTS: All protests regarding the bid solicitation process must be submitted in writing to the City Purchasing Manager within five (5) working days following the opening of bids. This includes all protests relating to advertising of bid notices, deadlines, bid opening, and all other related procedures under the Local Government Code, as well as any protests relating to alleged improprieties with the bidding process.

This limitation does not include protests relating to staff recommendations as to award of this bid. Protests relating to staff recommendations may be directed to the City Council by contacting the City Secretary.

Failure to Protest within the time allotted shall constitute a waiver of any protest.

ALTERING BIDS: Bid cannot be altered or amended after submission deadline. Any interlineation, or alteration made before opening time for sealed bids must be initialed by the signer of the bid, guaranteeing authenticity.

CHANGE ORDERS: No oral statement of any person shall modify or otherwise change, or affect the terms, conditions or specifications stated in the resulting contract. All change orders to the contract will be made in writing by the City of Lewisville.

ADDENDA: Any interpretations, corrections or changes to this Invitation for Bid and Specifications will be made by ADDENDA. Sole authority to issue addenda shall be vested in the City of Lewisville. Bidders shall acknowledge receipt of all addenda on bid form.

MINIMUM STANDARDS FOR RESPONSIBLE PROSPECTIVE BIDDERS: A prospective bidder must affirmatively demonstrate bidder's responsibility. A prospective bidder must meet the following requirements:

- Have adequate financial resources, or the ability to obtain such resources as required;
- Be able to comply with the required or proposed delivery schedule;
- Have a satisfactory record of performance;
- Have a satisfactory record of integrity and ethics;
- Be otherwise qualified and eligible to receive an award; and
- The City of Lewisville may request representation and other information sufficient to determine bidder's ability to meet these minimum standards listed above.

BIDDER SHALL PROVIDE with this bid response, all documentation required. Failure to provide this information may result in rejection of bid.

SUCCESSFUL BIDDER SHALL defend, indemnify and save harmless the City of Lewisville and all its officers, agents and employees and all entities, their officers, agents and employees who are participating in this contract from all suits, actions, or other claims of any character,

name and description brought for or on account of any injuries or damages received or sustained by any person, persons, or property on account of any negligent act or fault of the successful bidder, or of any agent, employee, subcontractor or supplier in the execution of, or performance under, any contract which may result from bid award. Successful bidder shall pay any judgment with cost which may be obtained against the City of Lewisville and participating entities growing out of such injury or damages.

TERMINATION FOR DEFAULT: The City of Lewisville reserves the right to enforce the performance of this contract in any manner prescribed by law or deemed to be in the best interest of the City in the event of breach or default of this contract. The City reserves the right to terminate the contract immediately in the event the successful bidder fails to 1) meet delivery schedules, or 2) otherwise perform in accordance with these specifications. Breach of contract or default authorizes the City to award to another bidder. Purchase elsewhere and charge the full increase in cost and handling to the defaulting successful bidder.

TESTING: Testing may be performed at the request of the City without expense to the City.

REMEDIES: The successful bidder and City of Lewisville agree that each party have all rights, duties, and remedies available as stated in the Uniform Commercial Code.

VENUE: This agreement will be governed and construed according to the laws of the State of Texas. This agreement is performable in Denton County, Texas.

SILENCE OF SPECIFICATION: The apparent silence of these specifications as to any detail or to the omission from it of a detailed description concerning any point shall be regarded as meaning that only the best commercial products and practices are to prevail. All interpretations of the specifications in this bid shall be made on the basis of this statement.

DEVIATIONS from specifications and alternate bids must be clearly shown on the bid form with complete information attached to form. They may or may not be considered.

NO EMPLOYEE of the City of Lewisville who has a financial interest in a prospective vendor shall participate in submitting a bid or proposal to conduct work for the City.

NO EMPLOYEE of the City of Lewisville shall receive any compensation for or as a result of a contract for goods or services purchased by the City if that employee was in a position to influence the City with respect to the contract.

ELIGIBLE BIDDER: Bidders are limited to those persons or firms who are qualified and engaged in a full-time business and can assume liabilities for any performance or warranty service required.

REJECTED ITEM(S): Item(s) that are rejected for failure to meet prescribed minimum specifications shall be returned to the supplier at no cost to the City of Lewisville.

INDEMNITY: The City of Lewisville will not accept a contract that contains any provision causing the City of Lewisville to indemnify the vendor for any reason.

VENDOR AGREEMENT: Any vendor agreements (service, maintenance, etc.) to be signed by the City of Lewisville must be submitted with your bid.

**CITY OF LEWISVILLE
PURCHASING DIVISION**

ADDITIONAL TERMS

ANTI-LOBBYING PROVISION

During the period between proposal / sealed bid submission date and the contract award, proposers, including their agents and representatives, shall not directly discuss or promote their proposal with any member of the City of Lewisville City Council or City staff except during City-Sponsored inquiries, briefings, interviews, or presentations, unless requested by the City.

This provision is not meant to preclude offerors from discussing other matters with City Council members or City staff. This policy is intended to create a level playing field for all potential offerors, assure that contract decisions are made in public, and to protect the integrity of the RFP / Bid Evaluation process. Violation of this provision may result in rejection of the offeror's proposal.

LAWS AND ORDINANCES

Laws and Ordinances: The Contractor shall always observe and comply with all Federal, State and local laws, ordinances and regulations which in any manner affect the Contract or the work and shall indemnify and save harmless the City against any claim arising from the violation of any such laws, ordinances and regulations whether by the Contractor or his employees.

PROTECTION OF RESIDENT WORKERS

Protection of Resident Workers: The City of Lewisville actively supports the Immigration and Nationality Act (INA) which includes provisions addressing employment eligibility, employment verification, and nondiscrimination. Under the INA, employers may hire only persons who may legally work in the United States (i.e., citizens and nationals of the U.S.) and aliens authorized to work in the U.S. The employer must verify the identity and employment eligibility of anyone to be hired, which includes completing the Employment Eligibility Verification Form (I-9). The Contractor and its Subcontractors shall establish appropriate procedures and controls so no services or products under the Contract Documents will be performed or manufactured by any worker who is not legally eligible to perform such services or employment. The City reserves the right to audit Contractor's or Subcontractor's employment records to verify the existence of a completed Employment Eligibility Verification Form (I-9) for every worker performing services or manufacturing products under the Contract Documents. The audit will be at the City's expense.

IMMIGRATION REFORM AND CONTROL ACT

Immigration Reform and Control Act (8 U.S.C. §1324a): The City of Lewisville supports the Immigration Reform and Control Act (IRCA) which is a comprehensive scheme prohibiting the employment of unauthorized aliens in the United States. The Contractor shall submit a declaration signed under penalty of perjury of the laws of the State of Texas stating that it has not been found in violation of IRCA by the United States Attorney General or Secretary of Homeland Security in the preceding five (5) years. The Contractor shall ensure that its Subcontractors submit a declaration signed under penalty of perjury of the laws of the State of

Texas stating that they have not been found in violation of IRCA by the United States Attorney General or Secretary of Homeland Security in the preceding five (5) years. The Contractor and its Subcontractors shall at all times during the term of the contract with the City comply with the requirements of IRCA and shall notify the City within fifteen (15) working days of receiving notice of a violation of IRCA. The City may terminate a contract with the Contractor if the City determines that (a) the Contractor or its Subcontractors have been untruthful regarding IRCA violations in the preceding five (5) years; (b) if the Contractor fails to ensure that its Subcontractors submit the aforementioned declaration; or (c) the Contractor or its Subcontractors fail to timely notify the City of an IRCA violation.

Contractor Name

Authorized Signature

Date

**CITY OF LEWISVILLE
PURCHASING DIVISION**

STATE RECIPROCAL REQUIREMENT

The City of Lewisville, as a governmental agency of the State of Texas, may not award a contract for general construction, improvements, services or public works projects or purchases of supplies, materials, or equipment to a non-resident bidder unless the non-resident's bid is lower than the lowest bid submitted by a responsible Texas resident bidder by the same amount that a Texas resident bidder would be required to underbid a non-resident bidder to obtain a comparable contract in the state in which the non-resident's principal place of business is located (Section 2252.002 of the Government Code). Bidder shall answer all the following questions by encircling the appropriate response or completing the blank provided.

1. Where is your principal place of business? _____

2. Only if your principal place of business is not in the state of Texas, please indicate:
 - A. In which state is your principal place of business located? _____

 - B. Does that state favor resident bidders (bidders in your state) by some dollar increment or percentage? YES NO

 - C. If "YES", what is that dollar increment or percentage? _____

NON-COLLUSION STATEMENT

The undersigned affirms that they are duly authorized to execute this contract, that this company, corporation, firms, partnership or individual has not prepared this bid in collusion with any other Bidder, and that the contents of this bid as to prices, terms or conditions of said bid have not been communicated by the undersigned nor by any employer or agent to any other person engaged in this type of business prior to the official opening of this bid.

Vendor:			
Address:			
City, State, Zip:			
Phone:			
Email:			
Bidder (Print Name):			
Bidder Signature:			
Job Title:			
Signature of company official authorizing this bid:			
Company Official (Print name):			
Job Title:			



Lewisville 2025 - Sustainability

Lewisville City Council unanimously adopted the Lewisville 2025 plan on July 14, 2014. The plan was developed after more than a year of public input and discussion that garnered hundreds of ideas and suggestions. That input was studied extensively by the Lewisville 2025 Steering Committee, City staff and professional consultants and formulated into the Lewisville 2025 plan. The plan provides a clear shared vision for the kind of community Lewisville wants to be when it turns 100 years old in 2025: a place that people choose to live, work and visit.

Lewisville 2025 identifies nine “Big Moves” to guide the community’s efforts toward being a thriving, desirable community. One of these Big Moves is sustainability. Lewisville defines sustainability in this way:

Limited resources, such as land, water, energy, clean air, natural assets, and public funds are used efficiently to provide a desirable quality of life and business climate today without reducing Lewisville’s ability to provide the desired quality of life and business climate for success of future generations.

The Purchasing Division’s goal is to support and encourage sustainable management practices through the purchase and use of materials, products and services that demonstrate environmental stewardship as well as fiscal and social responsibility. To that end, Lewisville will consider environmental factors such as but not limited to, recycled content, product life cycle, waste reduction, energy efficiency, toxicity, water consumption, and human health impacts when making purchasing recommendations. To assist City staff with evaluating these factors, prospective vendors may be required to provide specific information about their products and services that addresses environmental impacts.

Does Product or Service?	Yes	No	Details
Reduce energy consumption			
Reduce toxicity, including emissions			
Reduce waste			
Contain recyclable materials			
Reduce water consumption			
List other environmental impacts			

Attach supporting documentation if needed

EXHIBIT B

INSURANCE REQUIREMENTS **GENERAL CONTRACTS FOR SERVICES**

Service work, supplies requiring installation, Janitorial Services, Welding, Surveyors, Plumbing Contractors, Maintenance Agreements, Concessionaires, Tire Repairs, Tow Service, Painting, Electrical, Movers, Major street repairs and Waterline projects, etc.

Vendor shall procure and maintain for the duration of the contract, insurance against claims for injuries to persons or damages to property which may arise from or in connection with the performance of the work hereunder by the vendor, his agents, representatives, employees or subcontractors. The cost of such insurance shall be included in the vendor's bid.

A. MINIMUM SCOPE OF INSURANCE

Coverage shall be at least as broad as:

1. Insurance Services Office Commercial General Liability coverage "occurrence" form CG 00 01 (10 01). **"Claims Made" form is unacceptable.**
2. Workers' Compensation insurance as required by the Labor Code of the State of Texas, including Employers' Liability Insurance.
3. Automobile Liability – as required by the State of Texas, covering all owned, hired, or non-owned vehicles. Automobile Liability is only required if vehicle(s) will be used under this contract. Coverage not required for delivery services.

B. MINIMUM LIMITS OF INSURANCE

Vendor shall maintain limits throughout contract not less than:

1. Commercial General Liability: \$500,000 per occurrence/\$1,000,000 aggregate for bodily injury, personal injury and property damage. Policy will include coverage for:
 - a. Premises – Operations
 - b. Broad Form Contractual Liability
 - c. Products and Completed Operations
 - d. Personal Injury
 - e. Broad Form Property Damage
 - f. If applicable, Explosion Collapse and Underground (XCU) Coverage, Fire Damage, and Medical Expense.

NOTE: The aggregate loss limit applies to each project.

2. Workers' Compensation and Employer's Liability: Workers' Compensation Statutory limits as required by the Labor Code of the State of Texas and Employer's Liability minimum limits of \$500,000 per injury, \$500,000 per occurrence, and \$500,000 per occupational disease.
3. Automobile Liability - \$500,000 Combined Single Limit. Limits can only be reduced if approved by the HR Director or designee.

C. DEDUCTIBLES AND SELF-INSURED RETENTIONS

Any deductible or self-insured retentions must be declared to and approved by the City.

D. OTHER INSURANCE PROVISIONS

The policies are to contain, or be endorsed to contain the following provisions:

1. General Liability and Automobile Liability Coverages
 - a. The City, its officers, officials, employees, Boards and Commissions and volunteers are to be added as "Additional Insured" as respects liability arising out of activities performed by or on behalf of the vendor, products and completed operations of the vendor, premises owned, occupied or used by the Contractor. The coverage shall contain no special limitations on the scope of protection afforded to the City, its officers, officials, employees or volunteers. It is understood that the business auto policy under "Who is an Insured" automatically provides liability coverage in favor of the City. The coverage shall include defense of claims against the City as additional insured.
 - b. The vendor's insurance coverage shall be primary and non-contributory insurance as respects the City, its officers, officials, employees and volunteers. Any insurance or self-insurance maintained by the City, its officers, officials, employees or volunteers shall be excess of the vendor's insurance and shall not contribute with it.
 - c. Any failure to comply with reporting provisions of the policy shall not affect coverage provided to the City, its officers, officials, and employees, Boards and Commissions or volunteers.
 - d. The vendor's insurance shall apply separately to each insured against whose claim is made or suit is brought, except to the limits of the insured's liability.
2. Waiver of Subrogation – All Coverages
Each insurance policy required by this exhibit shall waive all rights of subrogation against the City, its officers, officials, employees, and volunteers for losses arising from work performed by the vendor for the City.
3. Notice of Cancellation - All Coverages
Each insurance policy required by this exhibit shall be endorsed to state that coverage shall not be suspended, voided, canceled or non-renewed by either party, reduced in coverage or in limits except after thirty (30) days prior written notice by certified mail, return receipt requested, has been given the City, or ten (10) days prior written notice for non-payment of premium.

E. ACCEPTABILITY OF INSURERS

The City prefers that insurance be placed with insurers with an A.M. Best's rating of no less than **A-:VI, or, A or better** by Standard and Poors.

F. VERIFICATION OF COVERAGE

Contractor shall furnish the City with certificates of insurance affecting coverage required. The certificates for each insurance policy are to be signed by a person authorized by that insurer to bind coverage on its behalf. Certificates of Insurance must be provided on forms approved by the Texas Department of Insurance. City will not accept Memorandums of Insurance or Binders as proof of insurance. The City reserves the right to require complete, certified copies of all required insurance policies at any time.

G. HOLD HARMLESS AND INDEMNIFICATION

THE CONSULTANT/CONTRACTOR AGREES TO DEFEND, INDEMNIFY AND HOLD THE CITY, ITS OFFICERS, AGENTS AND EMPLOYEES, HARMLESS AGAINST ANY AND ALL CLAIMS, LAWSUITS, JUDGMENTS, COSTS AND EXPENSES FOR PERSONAL INJURY (INCLUDING DEATH), PROPERTY DAMAGE OR OTHER HARM FOR WHICH RECOVERY OF DAMAGES IS SOUGHT, SUFFERED BY ANY PERSON OR PERSONS, THAT MAY ARISE OUT OF OR BE OCCASIONED BY CONSULTANT'S/CONTRACTOR'S BREACH OF ANY OF THESE TERMS AND CONDITIONS OR BY ANY NEGLIGENT OR STRICTLY LIABLE ACT OR OMISSION OR INTENTIONAL TORT, INTELLECTUAL PROPERTY INFRINGEMENT, OR FAILURE TO PAY A SUBCONTRACTOR OR SUPPLIER COMMITTED BY, CONSULTANT/CONTRACTOR, ITS OFFICERS, AGENTS, EMPLOYEES OR SUBCONTRACTORS, IN THE PERFORMANCE OF THIS AGREEMENT; EXCEPT THAT THE INDEMNITY PROVIDED FOR IN THE PARAGRAPH SHALL NOT APPLY TO ANY LIABILITY RESULTING FROM THE SOLE NEGLIGENCE OR FAULT OF THE CITY, ITS OFFICERS, AGENTS, EMPLOYEES OR SEPARATE CONTRACTORS, AND IN THE EVENT OF JOINT AND CONCURRING NEGLIGENCE OR FAULT OF THE CONSULTANT/CONTRACTOR AND THE CITY, RESPONSIBILITY AND INDEMNITY, IF ANY, SHALL BE APPORTIONED IN ACCORDANCE WITH THE LAW OF THE STATE OF TEXAS, WITHOUT WAIVING ANY GOVERNMENTAL IMMUNITY AVAILABLE TO THE CITY UNDER TEXAS LAW AND WITHOUT WAIVING ANY DEFENSES OF THE PARTIES UNDER TEXAS LAW AND THE CITY'S REASONABLE ATTORNEY'S FEES SHALL BE REIMBURSED IN PROPORTION TO THE CONSULTANT'S LIABILITY. THE PROVISIONS OF THIS PARAGRAPH ARE SOLELY FOR THE BENEFIT OF THE PARTIES HERETO AND NOT INTENDED TO CREATE OR GRANT ANY RIGHTS, CONTRACTUAL OR OTHERWISE, TO ANY OTHER PERSON OR ENTITY.

VENDOR SUPPLEMENTAL INFORMATION

The following information is required for contract development.

1. In what state was your business formed? _____

2. Provide the following information for the person authorized to execute contracts on behalf of your organization:

Name _____ Title _____
Email Address _____ Telephone No. _____
Mailing Address _____ City _____ State _____ Zip _____

3. Provide the following information for the contact person authorized to implement this contract on behalf of your organization:

Name _____ Title _____
Email Address _____ Telephone No. _____
Mailing Address _____ City _____ State _____ Zip _____

4. Provide the following information for the person authorized to receive notices and communications regarding this contract on behalf of your organization:

Name _____ Title _____
Email Address _____ Telephone No. _____
*Physical Business Address _____ City _____ State _____ Zip _____

**Notices and communications will be mailed to this physical address*

5. Select and complete one of the following:

a. **Sole Proprietorship**
i. Legal name of Sole Proprietor: _____
ii. Physical business address: _____
City _____ State _____ Zip _____

b. **General Partnership**
i. Legal name of Partnership: _____
ii. Physical business address: _____
City _____ State _____ Zip _____

[REMAINDER OF PAGE INTENTIONALLY LEFT BLANK]

VENDOR SUPPLEMENTAL INFORMATION

- c. **Limited Partnership**
- i. Legal name of Limited Partnership: _____
- ii. General Partner(s):
- If a legal entity, name of the entity: _____
 - If an individual, name of the individual: _____
- iii. Physical business address: _____
- City _____ State _____ Zip _____
- d. **Corporation**
- i. Legal name of Corporation: _____
- ii. Physical business address _____
- City _____ State _____ Zip _____
- e. **Limited Liability Company**
- i. Legal name of Limited Liability Company: _____
- ii. Physical business address _____
- City _____ State _____ Zip _____
- f. **Other Entity (not listed)**
- i. Legal name and type of Company: _____
- ii. Physical business address _____
- City _____ State _____ Zip _____

6. Does your business have 10 or more full-time employees? No Yes

7. a. Are you a publicly traded business? No Yes – where traded: _____

b. Are you a wholly owned subsidiary of a publicly traded business? No Yes – which publicly traded business: _____

8. a. Is your business registered with the Texas Secretary of State? No Yes

b. **If yes, please provide records or screenshot(s) from the Texas Secretary of State's website reflecting the name or names for which your business has been registered.**

In signing this form, I acknowledge that I have read the above and state that the information contained therein is true and correct.

Signature: _____ Date: _____

Print Name: _____ Print Title: _____

CITY OF LEWISVILLE
PURCHASING DIVISION

EXCEPTIONS

Bid _____

On the lines below, please list any exceptions taken to this bid invitation

ITEM #	DESCRIPTION

Signature: _____

Company: _____

Date: _____

No exceptions taken to this bid invitation.

Signature: _____

Company: _____

Date: _____



City of Lewisville

RFB #26-74-B

Minor Housing Rehabilitation Program (HVAC Repair/Replace Program)

Addendum No. 1

The bid document for the above-referenced project is amended as follows:

Questions from Bonfire:

Question: Were there any photos obtained? if so, can we get a copy emailed.

Answer: Yes, photos have been uploaded to the Files section of Bonfire.

Question: Also, Scop #F, G, I, call for increasing the tonnage to the home, are there Manual J documents available for that validation?

Answer: Manual J documentation was not prepared for the properties associated with this program.

Question: There was one more where the tonnage is being increased, # K.

Answer: Manual J documentation was not prepared for the properties associated with this program.

Question: Will invoices be accepted after each completed repair or installation?

Answer: Milestone payment language can be incorporated into the contract with the awarded vendor. Invoices may be submitted after each home is completed and passes their HVAC final inspection from the City's building inspectors.

Question: I am reaching out regarding Bid 26-74-B for the Minor Housing Rehabilitation Program, specifically the HVAC Repair and Replacement scope across the 14 residential homes. My firm is very interested in supporting the City of Lewisville in the successful execution of this initiative. As a project management and program execution firm, our approach is to facilitate delivery through a network of licensed, insured, and bonded HVAC contractors,



ensuring compliance, quality, and timely completion. In preparation for a potential bid submission, I would appreciate any additional clarity you can provide to ensure full alignment with the City's expectations. Specifically, I would like to confirm the following:

Whether the City prefers a prime contractor model or if a program management-led approach (utilizing vetted subcontractors) is acceptable?

Answer: The City prefers one prime contractor for this project.

Question: Any pre-qualified contractor requirements or local vendor participation expectations?

Answer: Contractor requirements are listed in Document 00 – Introduction and Bond Instructions in the Files section of Bonfire.

Question: Detailed scope breakdown per residence (repair vs. full replacement, tonnage, existing system types, etc.)?

Answer: The scope of work per residence can be found in Bonfire.

Question: Project timeline expectations, including start, milestones, and completion targets?

Answer: Work should be completed within 120 calendar days, or about one home per week.

Question: Inspection, permitting, and closeout requirements specific to this program?

Answer: All system repairs shall have permits pulled for any relevant work, dependent on the project's scope. All systems must have the relevant final inspection approved by City of Lewisville Building Inspectors before reimbursement is initiated. All permit fees are waived for the project.

Question: Any reporting, documentation, or compliance deliverables beyond ADA certification?

Answer: Contractors must comply with all applicable local, state, and federal laws and regulations, including but not limited to employment, labor, environmental, construction and



energy efficiency laws and regulations. City staff will utilize a third-party to verify wage requirements are met (Davis Bacon) by the awarded Contractor. City staff will complete environmental reviews of all homes.

Question: Insurance, bonding thresholds, and warranty expectations for awarded contractors?

Answer: Bond requirements can be found in Document 00 and 06, and insurance requirements can be found in Document 12, all found in the Files section of Bonfire.

Questions from Pre-Bid Meeting:

Question: Are all bonds required to be submitted with our bid, or just the bid bond?

Answer: Just the bid bond. The other required bonds would be submitted by the awarded vendor after the contract is executed.

Question: What are the permit requirements- do we pay for them?

Answer: Permits are required, but all permit fees are waived.

Question: Do we need to increase the tonnage?

Answer: If the scope of work calls for an increase, yes. If the awarded Contractor determines an increase is necessary to bring the home up to code, that should be communicated to the City.

Question: Can we do site visits of each home, or can pictures be provided instead? Page 2 of Document 00 says "Each bidder is expected to inspect the site of the work and to inform himself regarding all local conditions. Ignorance of existing conditions of the site will not be a basis for any changes after the award of the bid."

Answer: Site visits are not available. We will provide pictures of each unit, and each bidder should be familiar with the equipment condition of each home presented in the request for bid.



Question: What is the timeframe to complete work?

Answer: Work should be completed within 120 calendar days, or about one home per week.

Question: How will access to each home be coordinated?

Answer: The City representative will obtain the awarded Contractor's availability and convey that to the homeowner.

Question: Do we need to be registered as a vendor with SAM.gov?

Answer: No, that is not a City requirement.

Question: Will you be awarding the contract to multiple vendors?

Answer: The City intends to award to one vendor.

Question: What if a client wants work done on the weekend?

Answer: We have not experienced this in the past, but if we do, we would coordinate availability between the homeowner and the Contractor. We anticipate homeowners will not have a problem opening their home for this work during the week.

Additional Updates:

Pictures of Homeowner Current Systems

Pictures of homeowner current systems for each home have been uploaded to the Files section of Bonfire as Documents 15 – 28.

Bidders are advised to acknowledge receipt of Addendum No. 1 by filling in the appropriate blanks contained in the Proposal Form and, if applicable, the outer envelope of their bid.

#3

SCOPE OF WORK REQUIRED – CITY OF LEWISVILLE

Address: [REDACTED]

System Repair

Partial Install

Full System replacement

Summary of requirements to restore to operation & bring to code Recommendation is to replace the whole HVAC system. The Furnace, Evaporator Coil, Aux Drain Pan, Return Air Plenum and the outside Condensing Unit.

Overview of diagnostic findings The A.C. System is 14 years old and not efficient in cooling the home.

Current equipment – Model & Serial

	model #	Serial #
Outdoor Lennox	14ACX-036-230-14	[REDACTED]
Air handler/ <u>Furn</u> Lennox	M4180UHO7DE3LB	[REDACTED]
Evaporator Lennox	CH33-430-2F-3	[REDACTED]
Thermostat	Digital T-Stat	OK

Detail of requirements

Advantage Air Solutions Recommendation is to replace the whole HVAC system due to age & efficiency.

- ① 3-ton C-Cabinet Furnace
- ② 3-ton C-Cabinet Evaporator Coil & Aux Drain Pan
- ③ Return Air Plenum with 4" Filter Rack
- ④ 3-ton outside Condensing Unit.

LENNOX
DALLAS, TEXAS

ASSEMBLED
IN MEXICO

M/N 14ACX - 036 - 230 - 14

S/N 1912L08832

CONTAINS HFC-410A

DESIGN PRESSURE

FACTORY CHARGE

HI 446 PSIG

6 LBS 11 OZS

LO 236 PSIG

ELECTRICAL RATING

NOMINAL VOLTS: 208/230

1 PH

60 HZ

MIN 197

MAX 253

COMPRESSOR

FAN MOTOR

PH

1
14.1

PH

1

RLA

FLA

1.1

LRA

77.0

HP

1/6

MIN CKT AMPACITY
(WITH SECONDARY
SOURCE USE 19.3)
AMPERAGE MINIMUM

18.7

MAX FUSE OR CKT. BKR.
FUSIBLE/COUPE CIRCUIT
(HACR PER NEC) 30



Intertek

CONFORMS TO UL STD 1988
CERTIFIED TO CSA STD C22.2 NO. 250



FOR
OUTDOOR
USE

THIS EQUIPMENT IS SUITABLE FOR
POWERING WITH A SECONDARY
(SOLAR) SOURCE CIRCUIT. UTILITY
INTERACTIVE INVERTERS MUST BE
LISTED TO UL STANDARD 1741.
SECONDARY SOURCE SPECIFICATIONS:
240 VAC 60 HZ, 1 PH,
15.0 A MAXIMUM

SEE INSTALLATION INSTRUCTIONS

PATENT PENDING



LENNOX
2014 14 SEER
MINI SPLIT SYSTEM
S/N: 187248828
FACTORY CHARGE: 1.0
ELECTRICAL WIRING: 1.0
COMPRESSOR: 1.0
CONDENSER FAN MOTOR: 1.0
EVAPORATOR FAN MOTOR: 1.0
CIRCUIT BOARD: 1.0
THERMOSTAT: 1.0
WARRANTY: 5 YEAR LIMITED WARRANTY
SEE INSTALLATION INSTRUCTIONS
PART NO. 187248828

LENNOX
DALLAS, TEXAS

ASSEMBLED
IN MEXICO

M/N 14ACX - 036 - 230 - 14

S/N 1912L08832

CONTAINS HFC-410A

DESIGN PRESSURE

FACTORY CHARGE

HI 446 PSIG

6 LBS 11 OZS

LO 236 PSIG

ELECTRICAL RATING

NOMINAL VOLTS: 208/230

1 PH

60 HZ

MIN 197

MAX 253

COMPRESSOR

FAN MOTOR

PH 1

PH 1

RLA 14.1

FLA 1.1

LRA 77.0

HP 1/6

MIN CKT AMPACITY 18.7
(WITH SECONDARY
SOURCE USE 19.3)
AMPERAGE MINIMUM

MAX FUSE OR CKT. BKR.
FUSIBLE/COUPE CIRCUIT 30
(HACR PER NEC)



1912L08832

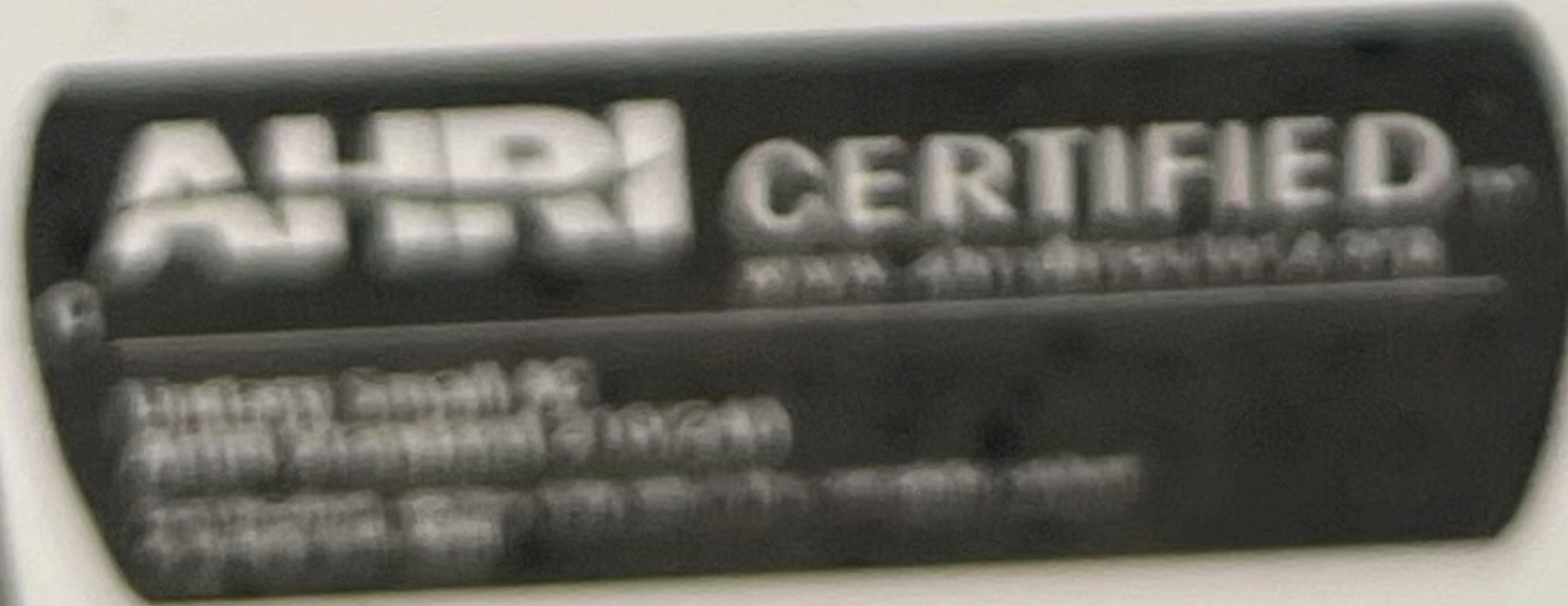

FOR
OUTDOOR
USE



THIS EQUIPMENT IS SUITABLE FOR
POWERING WITH A SECONDARY
(SOLAR) SOURCE CIRCUIT. UTILITY
INTERACTIVE INVERTERS MUST BE
LISTED TO UL STANDARD 1741.

SECONDARY SOURCE SPECIFICATIONS:
240 VAC 60 HZ, 1 PH,
15.0 A MAXIMUM

SEE INSTALLATION INSTRUCTIONS

PATENT PENDING

LENNOX

DALLAS, TX

TM

MODEL: CH33-43C-2F-3

SERIAL NO.: 6012K21226

REFRIGERANT: *SEE NOTE BELOW

DESIGN PRESS: MAX 480 PSIG

*MATCH METERING DEVICE WITH REFRIGERANT (R-22 OR R410A)

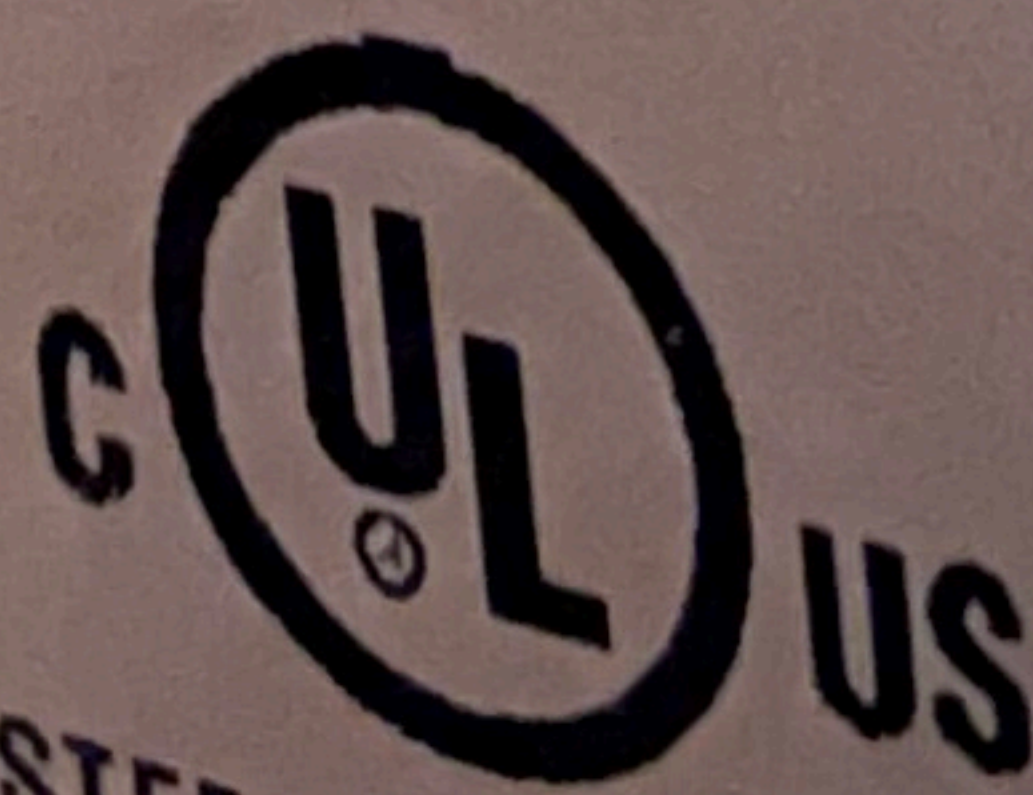

LISTED 3F86 TYPE 1-a

REFRIGERANT EVAPORATOR ALSO AS SECTION OF HEAT PUMP



SERIAL NUMBER

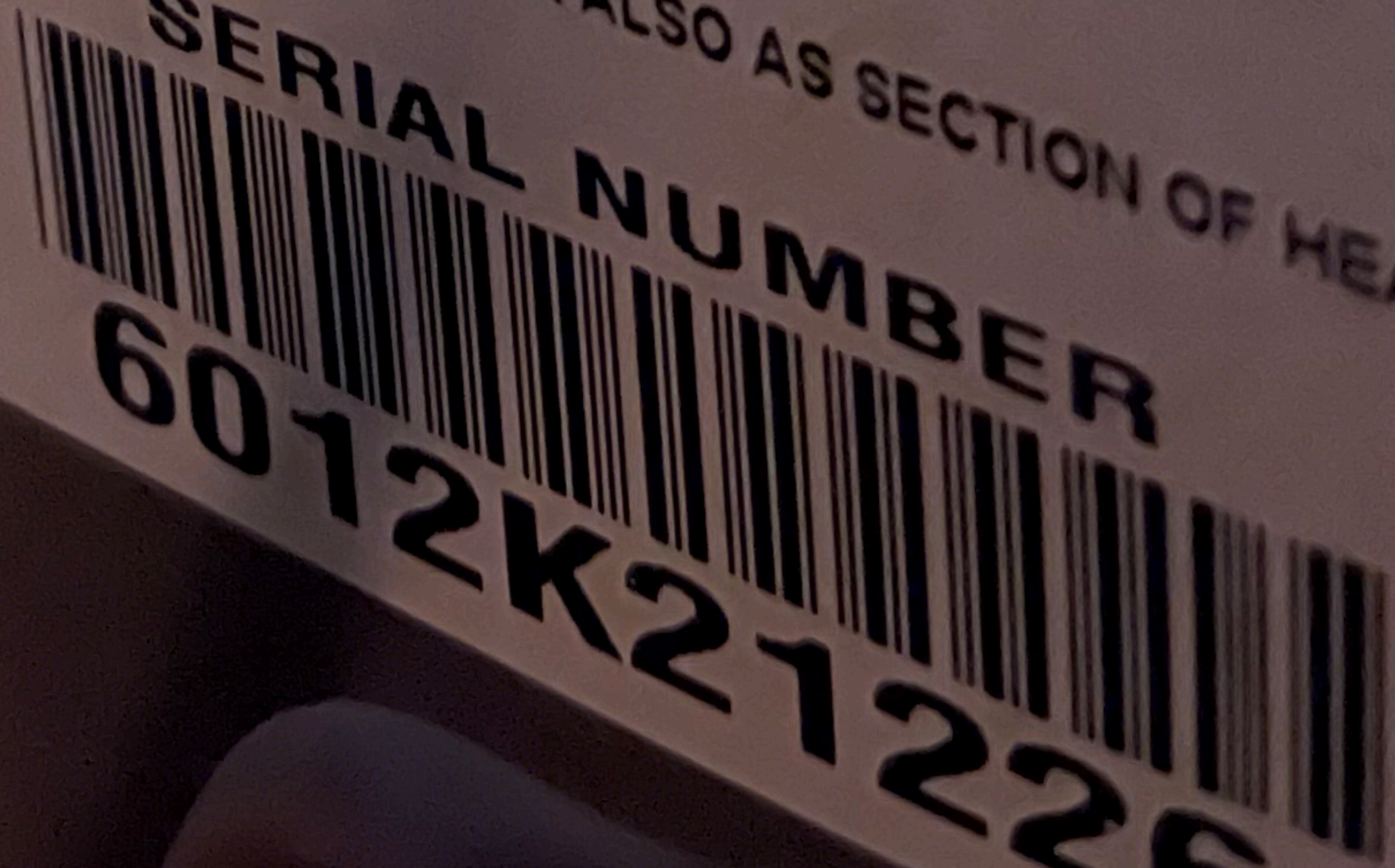

6012K21226

the insulation
duct during
maintenance,
will expose you
glass wool.
this may cause
er. (Fiberglass
own to the State
to cause
erglass wool
cause
skin, and eye
exposure to this
or for further
white sheets

#3

SCOPE OF WORK REQUIRED – CITY OF LEWISVILLE

Address: [Redacted]

System Repair Partial Install Full System replacement

Summary of requirements to restore to operation & bring to code Recommendation is to replace the Full HVAC system. Install a New Air Handler, Heat Kit, Aux Drain Pan and the outdoor Heat Pump. Will also need New Pad outside

Overview of diagnostic findings HVAC System is around 13yrs Old & has a Non repairable Refrigerant leak. The A.C. System is not efficient.

Current equipment – Model & Serial	MFG.	model #	Serial #
	Outdoor Amana	ASZ130421AF	[Redacted]
	Air handler Furn Goodman	ARUF42C14AD	[Redacted]
	Evaporator	N/A	
	Thermostat Honeywell	Digital T-Stage 2-Stage	

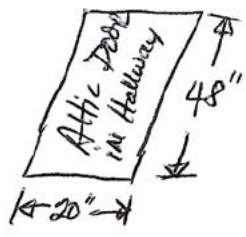

Detail of requirements

The Attic Door Assembly may have to be removed
Narrow Door 20"x48" in Hallway of Attic. No Plywood Floor in Attic
The outside Heat Pump will need New Electrical Whip & UV
INSULATION ON Uncovered suction line for A.C. unit.

- ① 3.5 ton Air Handler & 20KW Heat Kit
- ② Aux Drain Pan & H2O Safety Switch
- ③ Heat Pump outside 3.5 ton Unit
- ④ Condenser Pad for outside Unit.
- ⑤ 2pcs. of 12"x48" x 3/4" Plywood for Attic Floor



WARNING: This unit contains high voltage electrical components. Do not touch or tamper with these components. For more information, see the Safety Instructions in the Owner's Manual.

Model	Capacity	Efficiency	Input Power	Output Power	Current	Voltage	Frequency	Phase	Power Factor	Efficiency	Capacity	Efficiency	Input Power	Output Power	Current	Voltage	Frequency	Phase	Power Factor	Efficiency
120V	120V	120V	120V	120V	120V	120V	120V	120V	120V	120V	120V	120V	120V	120V	120V	120V	120V	120V	120V	120V

DANGER
This unit contains high voltage electrical components. Do not touch or tamper with these components. For more information, see the Safety Instructions in the Owner's Manual.

WARNING
This unit contains high voltage electrical components. Do not touch or tamper with these components. For more information, see the Safety Instructions in the Owner's Manual.

For more information, see the Safety Instructions in the Owner's Manual.

Product Information DP-000









GOODMAN MANUFACTURING COMPANY, L.P.
5151 SAN FELIPE ST., SUITE 500, HOUSTON, TEXAS 77056

MODEL ASZ130421AF SERIAL NO. 1402086075
A.C.VOLTS 208-230 PHASE 1 HERTZ 60
VOLTAGE RANGE MIN. 197 MAX. 253
MAX. FUSE AMPS OR MAX. CIRCUIT BREAKER 40
(TIME DELAY FUSE OR HACR CIRCUIT BREAKER REQUIRED)
MIN. CIRCUIT AMPS 23.5
FAN MOTOR FLA 1.1 H.P. 1/6
COMPRESSOR RLA 17.9 LRA 112
MAX. WORKING PRESSURE _____
FACTORY CHARGE OZ. R-410A 166
FACTORY TEST PRESSURE PSIG LOW 240 HIGH 450



WARNING
DISCONNECT ALL ELECTRICAL POWER BEFORE SERVICING.

ADVERTISSEMENT
COUPEZ TOUT LE COURANT AVANT TOUT ENTRETIEN
OU RÉPARATION.

ADVERTENCIA
DESCONECTE TODAS LAS FUENTES DE ENERGÍA ELÉCTRICAS
ANTES DE MANTENIMIENTO O SERVICIO TÉCNICO.

USE COPPER CONDUCTORS ONLY.
THIS EQUIPMENT SUITABLE FOR OUTDOOR USE.

PART NO. SR1421419

37887





Heating & Air Conditioning
Amana

BRICK CO.

①

SCOPE OF WORK REQUIRED – CITY OF LEWISVILLE

Address: [REDACTED]

System Repair

Partial Install

Full System replacement

Summary of requirements to restore to operation & bring to code

Recommendation is

to replace the full Heat Pump System, First Company Air Handler in Restroom above Bath Tub. 2.5 ton Heat Pump System in Home.

Overview of diagnostic findings

HVAC system is over 20 years old.

work but not very efficient to heat or cool Home.

2.5 ton Heat Pump System.

Current equipment – Model & Serial

MFG.	Model	Serial
Outdoor TRANE	2TWR3030A1000AA	[REDACTED]

Note Access Panel above Bath Tub in Restroom.

Air handler/ Furn First Company (above Bath tub in Restrm.)

Evaporator

one screw will have to be drilled out.

Thermostat Digital T-Stat

Unable to Access Equip.
Detail of requirements

The metal screws are missing from Access Door in Restroom.

Two Drywall screws are holding Door in place. which one of the screws is stripped.





XR 13

DATE 5/2006

MOD. NO. 2TWR3030A1000AA VOLTS 200/230
 SERIAL NO. 6213NWN4F PH 1
 MINIMUM CIRCUIT AMPACITY 13.0
 OVERCURRENT PROTECTIVE DEVICE USA CANADA
 MIN FUSE / BREAKER (HACR) 20 20
 MAX FUSE / BREAKER (HACR) 20 20
 HCFC - 22 6 LBS. 07 OZ. 200 - kg(SI)
 10 °F DESIGN SUBCOOLING

Climatuff DuraTuff Spine Fin Quick-Sess Weathertron

TRANE, A BUSINESS OF AMERICAN STANDARD

TYLER, TX 75707

ASSEMBLED IN USA



LISTED SECTION OF HEAT PUMP

23MF OUTDOOR USE

COMPR. MOT. 9.5 RLA
 O.D. MOT. 0.90 FLA
 M.E.A. NO.
 DESIGN PSI - HIGH 300 LOW 300

200/230 V 63 LRA
 200/230 V 1/8 HP
 F. ID. 33M



CERTIFICATION APPLIES ONLY WHEN THE COMPLETE SYSTEM IS LISTED WITH ARI





#4

SCOPE OF WORK REQUIRED – CITY OF LEWISVILLE

Address: [Redacted]

System Repair Partial Install Full System replacement

Summary of requirements to restore to operation & bring to code Recommendation is to replace Air Handler Heat Kit Filter Pack and outdoor Heat Pump Unit.

Overview of diagnostic findings The HVAC System is not efficient, over 15 years old. Very high Utility Bill. Requesting a more efficient HVAC System.

Current equipment – Model & Serial	Model #	Serial #
Outdoor RHeem	I3PJT24A01	[Redacted]
mfg. Model #		Serial #
Air handler/ Furn RHeem	RHSL-HM2417JA	N/A
Evaporator	N/A	
Thermostat	Honeywell - Digital T-Stat	

Utility Closet
Opening in Living Rm
23" X 54 1/2"

Detail of requirements

- Install a new ① 2-ton Air Handler & Heat Kit
- ② Filter Pack for A/H
- ③ Heat Pump 2-ton Unit.
- ④ Increase Return Air Filter From 16" X 18" to 24" X 18"



ENERGYGUIDE
Annual Fuel Utilization Efficiency
100
Lower Efficiency Higher Efficiency
Efficiency ranges based only on Electric Systems.
For more information, visit www.fda.gov/energyguide.

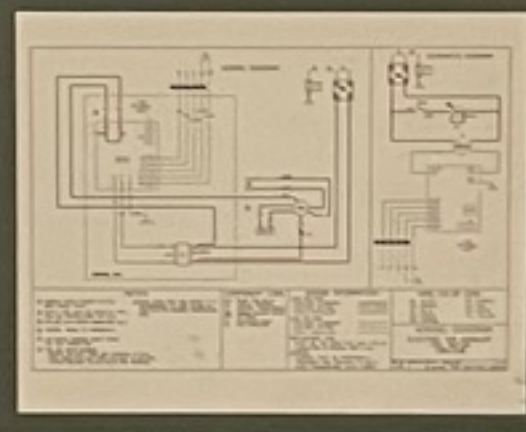

PRECAUCION!
Antes de hacer ajustes a la
dispositivo termostático, tome
las medidas de precaución
antes de manipularlo.

WARNING
This system contains R-410A. Repairing
or replacing the R-410A may require
specialized tools and training.
Do not attempt to repair or
replace the R-410A unless you are
qualified.

NOTICE / AVIS
This system contains R-410A. Repairing
or replacing the R-410A may require
specialized tools and training.
Do not attempt to repair or
replace the R-410A unless you are
qualified.

R-410A
This system contains R-410A. Repairing
or replacing the R-410A may require
specialized tools and training.
Do not attempt to repair or
replace the R-410A unless you are
qualified.

NOTICE
This system contains R-410A. Repairing
or replacing the R-410A may require
specialized tools and training.
Do not attempt to repair or
replace the R-410A unless you are
qualified.

HDX 16x20x1
HDX 16x20x1
HDX 16x20x1

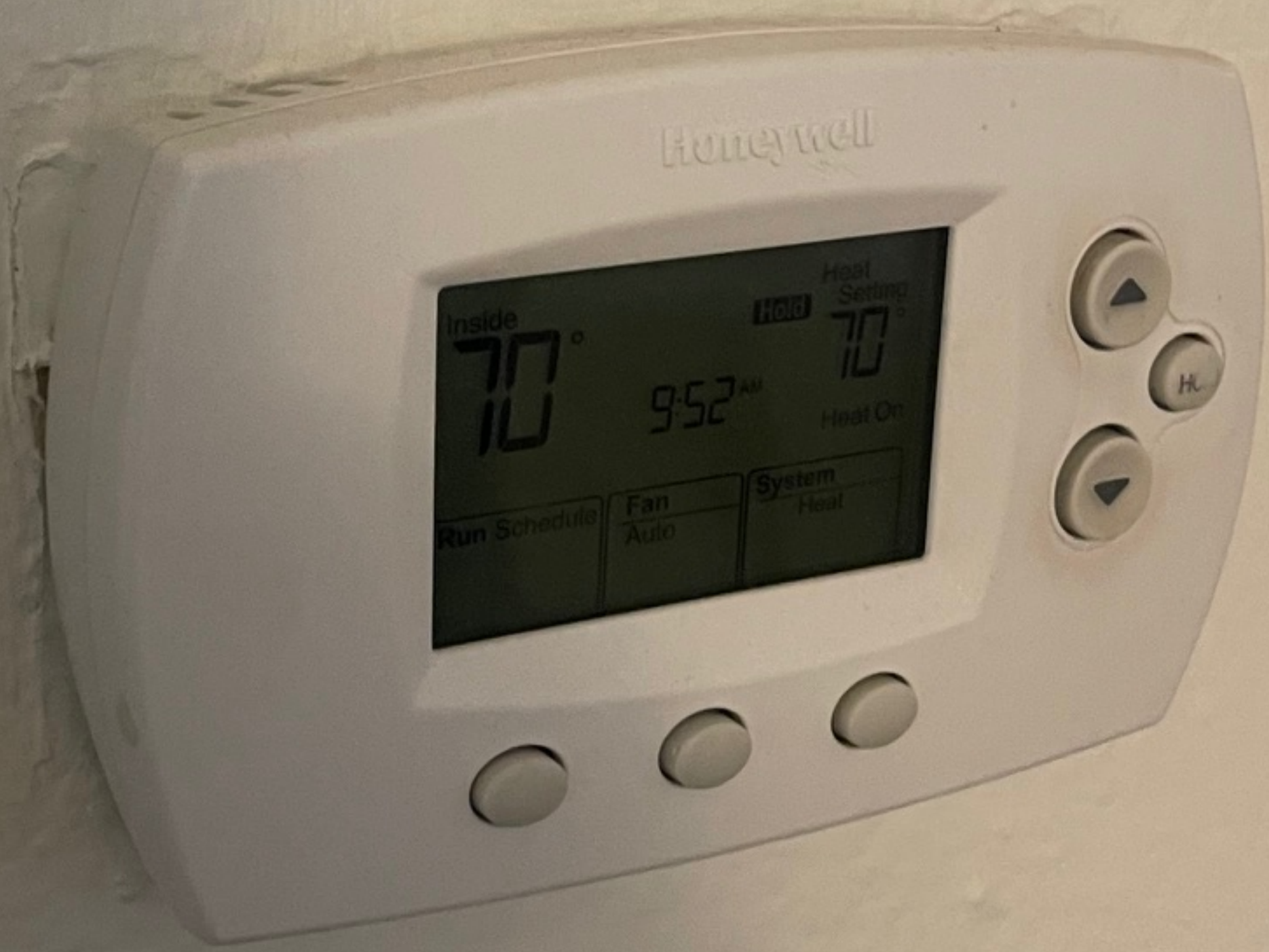

Honeywell

Inside 70°
9:52 AM
Heat Setting 70°
Heat On
Run Schedule Fan System
Auto Heat

▲
H.C.
▼

○ ○ ○

Rheem Sales Company

Acondicionador de Aire Central

Modelo: RHSL-HM2417JA

Tensión Nominal: ~ 208/240 V

Fases: 1

Frecuencia: 60 Hz

Corriente Nominal: 3,0 A

Requiere Tierra Fisica

HECHO EN MÉXICO

Leer Manual de Instalación y Operación Anexo

92-22050-20-00



¡ PRECAUCION !

Antes de tener acceso a los dispositivos terminales, todos los circuitos de alimentación deben ser interrumpidos.

92-22204-48-00

MF
FR

M

V

AT

HE

D
DE C

N

RXE

RXB

RXBH

RXBH

RXBH

RXBH-

RXBH-1

RXBH-1

RXBH-17

RXBH-17

RXBH-172

RXBH-172

RXBH-1724

S = SINGLE CIRCUIT/CIRCUIT SIMPLE
INDOOR BLOWER MOTOR LOAD INCLUD
EXTERNAL STATIC RANGE .1 TO .5 IN. W



MODEL NO. /		MFD./FAB	06/2011
MODÈLE N°	13PJL24A01		
SERIAL NO. /		OUTDOOR USE /	
N° DE SÉRIE	7688W261121199	USAGE EXTÉRIEUR	
VOLTS	208/230	PHASE. 1	HERTZ 60
COMPRESSOR /			
COMPRESSEUR	R.L.A. 12.8/12.8	L.R.A. 58.3	
OUTDOOR FAN MOTOR /			
MOTEUR VENTIL. EXT.	F.L.A. 0.6	HP. 1/10	
MIN. SUPPLY CIRCUIT AMPACITY /			
COURANT ADMISSIBLE D'ALIM. MIN.		17/17	AMP
MAX. FUSE OR CKT. BRK. SIZE* /			
CAL. MAX. DE FUSIBLE/DISJ*	25/25	AMP	
MIN. FUSE OR CKT. BRK. SIZE* /			
CAL. MIN. DE FUSIBLE/DISJ*	20/20	AMP	
DESIGN PRESSURE HIGH /			
PRESSION NOMINALE HAUTE	550 PSIG/3792 kPa		
DESIGN PRESSURE LOW /			
PRESSION NOMINALE BASSE	250 PSIG/1724 kPa		
OUTDOOR UNITS FACTORY CHARGE /			
CHARGE USINE D'UNITÉS EXT.	91 oz/2580g	R410A	
TOTAL SYSTEM CHARGE /			
CHARGE TOTALE SYSTÈME		R410A	
SEE INSTRUCTIONS INSIDE ACCESS PANEL.			
VOIR INSTRUCTIONS DANS LE PANNEAU D'ACCÈS			
RHEEM MANUFACTURING COMPANY			
FORT SMITH, ARKANSAS			
*HACR TYPE BREAKER FOR U.S.A. /		ASSEMBLED IN MEXICO	
DISJONCTEUR DIFFÉRENTIEL		92-22050-17	

NOTICE / AVIS

AIR / NON-CONDENSIBLE GASES / MOISTURE

These contaminants in the refrigerant system can cause:
 High head pressure with normal suction pressure
 Low suction pressure with normal head pressure
 Gurgling or pulsating noise of expansion device
 Fluctuating discharge and vapor pressures

Remove refrigerant from system per the Federal Clean Air Act. Evacuate the system to 29.9 inches Hg vacuum. Recharge system with new or reclaimed refrigerant per ANSI Z60 purity standard as required by EPA.

AIR / GAZ NON CONDENSIBLE / HUMIDITÉ

Ces contaminants dans le système réfrigérant peuvent causer:
 Pression de tête élevée avec pression d'aspiration normale
 Faible pression d'aspiration avec pression de tête normale
 Bruit de gargouillement ou de pulsation au détendeur
 Fluctuation de pression de vapeur et de débit

Retirez le réfrigérant du système en respectant la loi fédérale sur l'élimination de l'air. Évacuez le système jusqu'à un vide de 29,9 pouces de mercure. Rechargez le système avec un réfrigérant neuf ou recyclé conformément à la norme de pureté ANSI Z60, tel qu'exigé par l'EPA.

B-410A



NOTICE/AVIS

R-410A

WARNING

NOTICE

#2

SCOPE OF WORK REQUIRED – CITY OF LEWISVILLE

Address: [REDACTED]

System Repair

Partial Install

Full System replacement

Summary of requirements to restore to operation & bring to code A.A.S. Recommendation

is replace the whole HVAC System, The Air Handler, Heat Kit 18KW Assembly, Aux Drain Pan and the outdoor Condensing Unit/Heat Pump.

Overview of diagnostic findings

The outside Condensing Unit/ is OVER 20 years old. The Air Handler is only 6 years old, however it is not compatible with the New 454B Refrigerant.

Current equipment – Model & Serial

Outdoor Carrier (Missing the Data Tag info.)

Air handler/ Furn TRANE TEM4A0C48541SBA [REDACTED]

Evaporator N/A

Thermostat Zoning Board & two T-Stats

Detail of requirements

A.A.S. Recommendation are to replace the following items below:
Need a small section of 3/4" Plywood replaced in order to Access Air Handler in Attic on 2nd FL. of Condo. 18" X 72" PC. of Plywood. The one HVAC system takes care of the upstairs & Downstairs Area. The Unit has a zoning Board & two thermostats.

- ① 4-ton Air Handler and Heat Kit Assembly
- ② Aux Drain Pan & H₂O Safety Switch
- ③ Outdoor 4-ton Condensing Unit

ON QUALITY FULL
REPUTATION BRANDS
ELECTRICAL SUPPLIES
AND COMPONENTS
FOR YOUR SYSTEM
AND YOUR PEACE OF MIND.
TRANE
A THOMSON COMPANY
10000 W. 16th Ave., Omaha, NE 68130
800.447.2373
www.trane.com



WARNING **AVERTISSEMENT** **ADVERTENCIA**

DO NOT TOUCH THE REFRIGERANT LINES OR CONNECTIONS. REFRIGERANT IS UNDER HIGH PRESSURE AND CAN CAUSE SEVERE BURNING OR FROSTBITE. DO NOT TOUCH THE REFRIGERANT LINES OR CONNECTIONS. REFRIGERANT IS UNDER HIGH PRESSURE AND CAN CAUSE SEVERE BURNING OR FROSTBITE. DO NOT TOUCH THE REFRIGERANT LINES OR CONNECTIONS. REFRIGERANT IS UNDER HIGH PRESSURE AND CAN CAUSE SEVERE BURNING OR FROSTBITE.

WARNING **AVERTISSEMENT** **ADVERTENCIA**

DO NOT TOUCH THE REFRIGERANT LINES OR CONNECTIONS. REFRIGERANT IS UNDER HIGH PRESSURE AND CAN CAUSE SEVERE BURNING OR FROSTBITE. DO NOT TOUCH THE REFRIGERANT LINES OR CONNECTIONS. REFRIGERANT IS UNDER HIGH PRESSURE AND CAN CAUSE SEVERE BURNING OR FROSTBITE. DO NOT TOUCH THE REFRIGERANT LINES OR CONNECTIONS. REFRIGERANT IS UNDER HIGH PRESSURE AND CAN CAUSE SEVERE BURNING OR FROSTBITE.

AIR HANDLER

Model	Capacity (BTU/hr)	Capacity (kW)	Capacity (Tons)	Capacity (HP)
AAH036	36,000	10.5	3.0	1.5
AAH048	48,000	14.0	4.0	2.0
AAH060	60,000	17.5	5.0	2.5
AAH072	72,000	21.0	6.0	3.0
AAH084	84,000	24.5	7.0	3.5
AAH096	96,000	28.0	8.0	4.0
AAH108	108,000	31.5	9.0	4.5
AAH120	120,000	35.0	10.0	5.0
AAH132	132,000	38.5	11.0	5.5
AAH144	144,000	42.0	12.0	6.0
AAH156	156,000	45.5	13.0	6.5
AAH168	168,000	49.0	14.0	7.0
AAH180	180,000	52.5	15.0	7.5
AAH192	192,000	56.0	16.0	8.0
AAH204	204,000	59.5	17.0	8.5
AAH216	216,000	63.0	18.0	9.0
AAH228	228,000	66.5	19.0	9.5
AAH240	240,000	70.0	20.0	10.0
AAH252	252,000	73.5	21.0	10.5
AAH264	264,000	77.0	22.0	11.0
AAH276	276,000	80.5	23.0	11.5
AAH288	288,000	84.0	24.0	12.0
AAH300	300,000	87.5	25.0	12.5
AAH312	312,000	91.0	26.0	13.0
AAH324	324,000	94.5	27.0	13.5
AAH336	336,000	98.0	28.0	14.0
AAH348	348,000	101.5	29.0	14.5
AAH360	360,000	105.0	30.0	15.0





A large, grey metal electrical control panel is mounted on a metal frame. The panel features a prominent red 'TRANS' logo in the center. To the left of the logo are two black rectangular components, possibly relays or switches. Above the logo, there are several yellow warning labels with black symbols and text, including a lightning bolt symbol. Below the logo, a white technical data sheet is affixed to the panel, containing various tables and text. The panel is surrounded by silver reflective insulation.

Two blue electrical control boxes are mounted on a vertical wooden beam. They are connected to the main panel via white PVC piping. The boxes are stacked vertically, with the top one being slightly larger than the bottom one. Black and orange wires are connected to the boxes. The background consists of silver reflective insulation.

A grey electrical terminal block is mounted on a wooden beam. It has several terminals, some of which are connected to orange and black wires. The terminal block is labeled 'HEP' and 'VAN'. The background consists of silver reflective insulation.



#4

SCOPE OF WORK REQUIRED – CITY OF LEWISVILLE

Address: [REDACTED]

System Repair

Partial Install

Full System replacement

Summary of requirements to restore to operation & bring to code

Recommendation is

to change out the Full HVAC System along with the Hard

Ductwork, Six drop from Supply Air Plenum. 4 BRM, 2 Restrooms, Kitchen, Living Rm, Dining Rm.

Overview of diagnostic findings

The 4-ton HVAC System is not efficient

any more. The HVAC System is over 16 yrs. Old & in poor condition

Not able to cool home in Summer. The Ductwork has leaks & needs to be replaced.

Current equipment – Model & Serial

	MFG.	Model #	Serial #
Outdoor	Heil	N4A348GKB200	[REDACTED]
Air handler/ ^{Furn}	Ruud	C-Cabinet 100K	BTU's missing label
Evaporator	ICP	EDM4X48FA2	[REDACTED]
Thermostat	Digital	T-Stat	[REDACTED]

Detail of requirements

Need to replace the following equipment:

- ① 5-ton Gas Furnace 100,000 BTU'S C-Cabinet
- ② 5-ton Evaporator Coil & Aux Drain Pan.
- ③ 5-ton Condenser & Condenser Pad outside.
- ④ Supply & Return Air Plenums in Attic
- ⑤ The Supply Air Ductwork Runs from A.C. Unit to the BRMs, Restrooms, Kitchen, Dining Rm & Living Rm.
- ⑥ Digital Thermostat in Hallway.
- ⑦ Needs more insulation in Attic





Silhouette II
Gas Furnace



BURNER
COMPARTMENT
DOOR

ENERGYGUIDE

Compare the Energy Efficient Furnace with Others Before You Buy.

The Model's Efficiency
AFUE

Energy efficiency range of all similar models
Most Efficient
78.0
Model
Efficient
80.0

Gas furnaces that have higher AFUEs are more energy efficient.

GARY'S
AIR CONDITIONING & HEATING
24 HOUR SERVICE
(214) 219-1349

FOR YOUR SAFETY READ BEFORE OPERATING

WARNING: Failure to read the instructions before attempting to install, operate, or maintain this furnace may result in property damage, personal injury, or death.

WARNING: This furnace is not to be used for space heating in a room where it is not intended to be used. See the instructions for the correct use of this furnace.

WARNING: This furnace is not to be used for space heating in a room where it is not intended to be used. See the instructions for the correct use of this furnace.

WARNING: This furnace is not to be used for space heating in a room where it is not intended to be used. See the instructions for the correct use of this furnace.

WARNING: This furnace is not to be used for space heating in a room where it is not intended to be used. See the instructions for the correct use of this furnace.

IMPORTANT INFORMATION TO INSTALLER

WARNING: This furnace is not to be used for space heating in a room where it is not intended to be used. See the instructions for the correct use of this furnace.

WARNING: This furnace is not to be used for space heating in a room where it is not intended to be used. See the instructions for the correct use of this furnace.

WARNING: This furnace is not to be used for space heating in a room where it is not intended to be used. See the instructions for the correct use of this furnace.

WARNING: This furnace is not to be used for space heating in a room where it is not intended to be used. See the instructions for the correct use of this furnace.

WARNING: This furnace is not to be used for space heating in a room where it is not intended to be used. See the instructions for the correct use of this furnace.

WARNING
AVERTISSEMENT
FIRE HAZARD / RISQUE DE FEU

Do not use this furnace for space heating in a room where it is not intended to be used. See the instructions for the correct use of this furnace.

WARNING
RISQUE D'EXPLOSION
RISQUE D'ÉLECTROCUTION

Do not use this furnace for space heating in a room where it is not intended to be used. See the instructions for the correct use of this furnace.



Silhouette II
Gas Furnace

RUUD

WARNING: BACKDRAFTING HAZARD - DO NOT BLOCK THE INTAKE AIRWAYS. See instructions for proper installation. See instructions for proper venting. See instructions for proper gas line installation.



SERIAL E102611922

PROD N4A348GKB200

MODEL N4A348GKB200

METERING TXU NA

DEVICE INDOOR OUTDOOR

FACTORY CHARGED R410A

7.00 LBS 3.18 KG

INDOOR TXU SUB COOLING 15 °F

POWER SUPPLY 208-230 VOLTS AC

1 PH 60 HZ

PERMISSIBLE VOLTAGE AT UNIT

253 MAX 197 MIN

SUITABLE FOR OUTDOOR USE

COMPRESSOR 208/230 VOLTS AC

1 PH 60 HZ

19.9 RLA 109.0 LRA

FAN MOTOR 208/230 VOLTS AC

1 PH 60 HZ

1/4 HP 1.4 FLA

DESIGN/TEST PRESSURE GAGE

HI 450 PSI 3103 KPA

LO 250 PSI 1724 KPA

MAX. DESIGN/WORKING PRESSURE

700 PSIG 482.5 KPA

MINIMUM CIRCUIT AMPS 26.2

MAX FUSE MAX CKT-BKR (A) 40 A

40 A * HACR TYPE RECOMMENDED

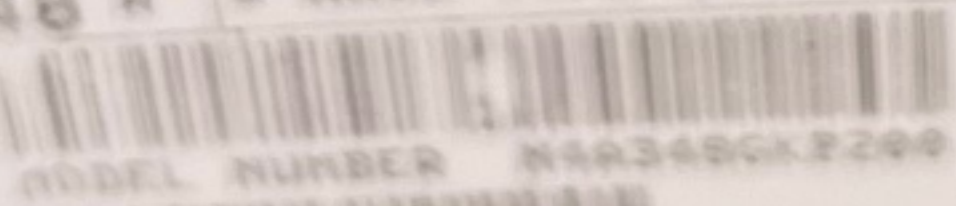

MODEL NUMBER N4A348GKB200

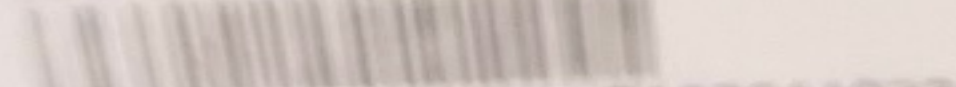

SERIAL NUMBER E102611922

DATE OF MANUFACTURE JUN 2010

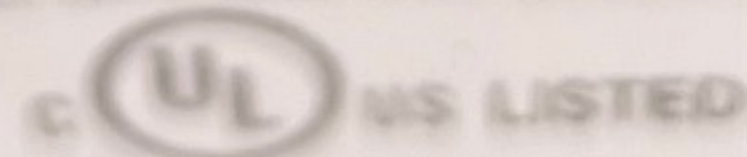





2.

SCOPE OF WORK REQUIRED – CITY OF LEWISVILLE

Address: [REDACTED]

System Repair Partial Install Full System replacement

Summary of requirements to restore to operation & bring to code Recommendation is to replace the full HVAC System in Attic & outdoor A.C. Condenser. 4-ton Drive Furnace, B-Cabinet & Allstyle Coil (Very Tight Attic space)

Overview of diagnostic findings HVAC is NOT operational, A.C. Unit is over 20 years old.

Current equipment – Model & Serial	Mfg.	Model #	Serial #
Very Small Attic Area.	Outdoor American Std.	2A7B0036A1000AA	[REDACTED]
	Air handler/Furn American Std.	AU080C936K1	[REDACTED]
	Evaporator Allstyle Coil	ACL3644218	[REDACTED]
	Thermostat	Nest T-Stat.	[REDACTED]

Detail of requirements

Narrow Attic Door opening upstairs Hallway

20"X52" Dia. opening.

Recommendation is a

- ① 4-ton B-cabinet Furnace
- ② 4-ton Allstyle Coil in Attic
- ③ Return Air Plenum with Filter Pack
- ④ 4-ton Straight Cool Condenser
- ⑤ Replace outdoor Condenser Pad
- ⑥ Install New Electrical Whip.

8 33712-12500
4RV - 90
ADJ. ELBOW 90 DEG
4" X 90"

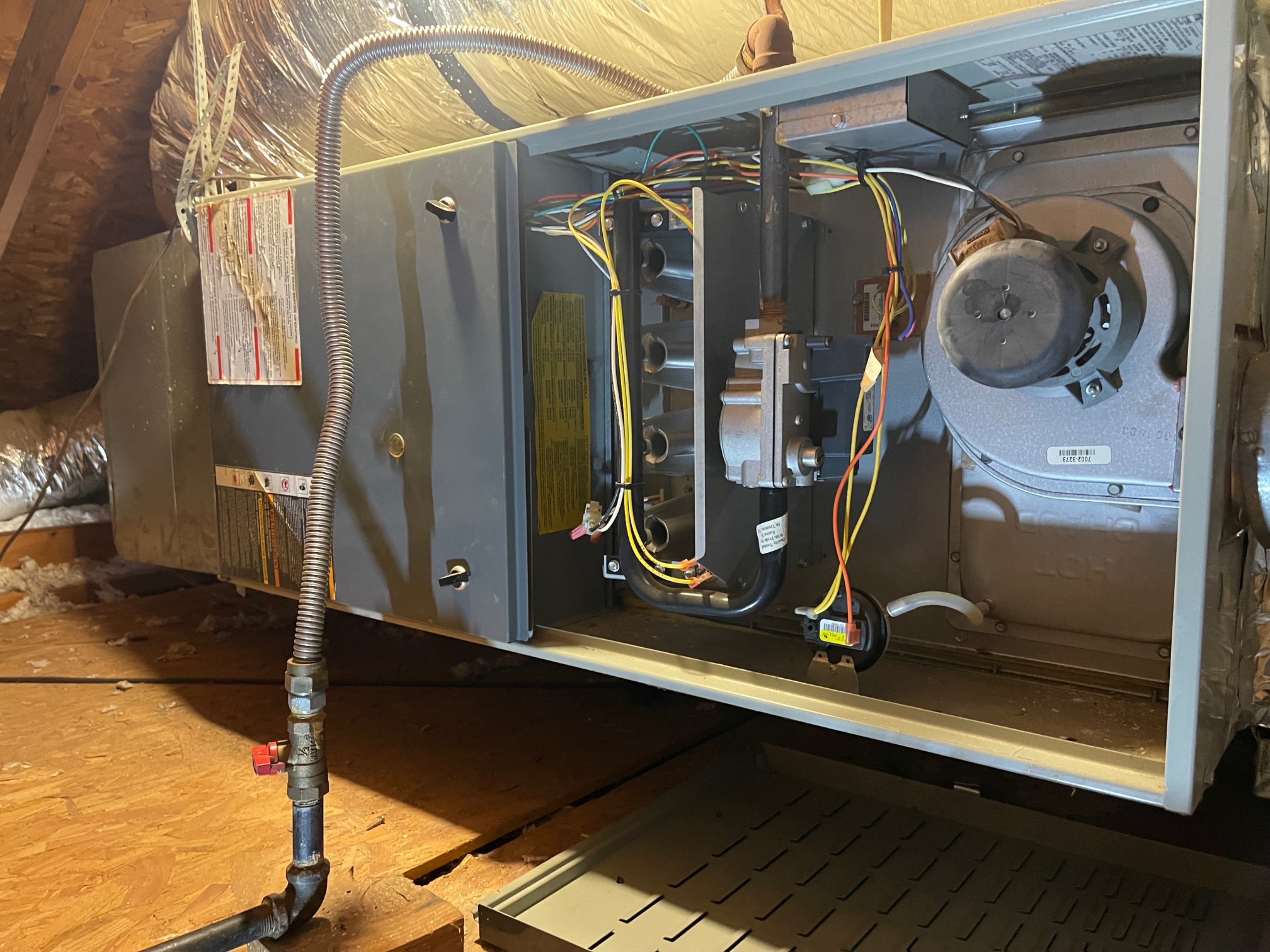



MODEL:

AUD080C936K1

SERIAL NO:

2323SS571G

LINE:

11



AMERICAN STANDARD INC.
THE TRANE COMPANY
TRENTON N. J. 08619
Assembled in U.S.A.



MODEL NO./NUMERO DE MODELE: AUD080C936K1
SERIAL NO./NUMERO DE SERIE: 232355710

CATEGORY I FORCED AIR FURNACE FOR INDOOR INSTALLATION ONLY IN A BUILDING
CONSTRUCTED ON - SITE CATEGORIE I GÉNÉRATEUR D'AIR CHAUD A AIR FORCEE POUR
INSTALLATION A L'INTÉRIEUR SEULEMENT, DANS UN BATIMENT CONSTRUIT SUR LE SITE.
ELECTRIC 115 V. 60 HZ 1 PH, MAXIMUM TOTAL INPUT 8.5 | AMPS.

ELECTRIQUE 115 V. 60 HZ 1 PH, PUISSANCE D ENTREE TOTALE MAXIMUM 8.5 | A.
FACTORY EQUIPPED FOR NATURAL GAS/AGENCE A L'USINE POUR NATUREL GAZ.
EQUIPPED WITH NO. 45 DRILL SIZE ORIFICE/L'ORIFICE EST IDENTIQUE AU TROU D'UN FORET N. 45

HOURLY INPUT RATING	MANIFOLD PRESSURE	NATURAL GAS/	PROPANE/
DEBIT CALORIFIQUE	PRESSION A LA TUBULURE	GAZ NATUREL	GAZ PROPANE
BTU/H	INCHES W.C. PO/C.E. (KPA)	INCH W.C. (KPA)	INCH W.C. (KPA)
80,000	3.5	PO. C.E. (KPA)	PO. C.E. (KPA)
	(.87)	13.8 (3.43)	13.8 (3.43)
MAXIMUM PERMISSIBLE GAS SUPPLY PRESSURE TO FURNACE		13.8 (3.43)	13.8 (3.43)
PRESSION MAXIMUM D'ALIMENTATION EN GAZ A CHAUDIERE		5.0 (1.24)	11.0 (2.49)
MINIMUM GAS SUPPLY PRESSURE FOR PURPOSES OF			

ALLSTYLE
CABINETRY

CABINETRY

DESIGN PRESURE
SERIAL

MODEL

121836-N21

2103-KTS

200 PSI

DRAW

2

PREPARED BY



American Standard

#1

SCOPE OF WORK REQUIRED – CITY OF LEWISVILLE

Address: [REDACTED]

System Repair

Partial Install

Full System replacement
(Down Stair System)

Summary of requirements to restore to operation & bring to code

Recommendation is to replace the whole Downstairs 2-ton First Company Air Handler with Heat Kit & the 2-ton outside Condensing unit.

Overview of diagnostic findings

Both the Air Handler & outside Condenser are over 35 years old. HVAC System is not efficient

Current equipment – Model & Serial

Outdoor YORK 2-ton Condensing Unit

Air handler/ Furn FIRST Company Air Handler

Evaporator N/A

Thermostat Digital T-stat (Needs to be replaced)

(Labels were not legible)

Detail of requirements

First Company Air Handler in Restroom (Downstairs Unit)

The YORK 2-ton Condenser is in very tight Area. Will need the Condenser Pad Replaced.

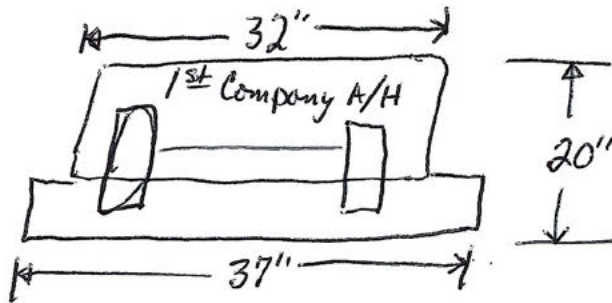

May be necessary to cut small openings in wood fence & install a 14" x 14" opening for the new Condenser to get AIR.

CAUTION — UNIT FACTORY
WIRED FOR 240 VOLTS
FOR 208 VOLT APPLICATION TRANSFORMER
WIRING MUST BE CHANGED — SEE WIRING
DIAGRAM



CAUTION - HIGH VOLTAGE
DO NOT TOUCH THIS SURFACE
OR THE SURFACE OF THE
COMPONENTS OF THE UNIT











#3

SCOPE OF WORK REQUIRED – CITY OF LEWISVILLE

Address: [Redacted]

System Repair Partial Install Full System replacement

Summary of requirements to restore to operation & bring to code Recommendations are

to replace the 2-ton system with a New 3-ton Air Handler &

3-ton Heat Pump. However there is no plywood in Attic to walk on & Access the Air Handler. Will Have to Access by Cutting Sheet Rock. May need to increase the Return Air from 20" x 20" to 25" x 30" Return.

Overview of diagnostic findings

↓
HVAC System is under sized & over 20 years old, will Not get below 80° in Summer when outside temperature is 90°F

Current equipment – Model & Serial	MFG.	Model #	Serial #
	Outdoor Goodman	CK24-18	[Redacted]
Note: No Ladder in House to Access Air Handler.	Air handler/Furn	Rheem 2-ton Air Handler & Heat Kit	
<u>20" x 23" opening upstairs</u>	Evaporator	N/A	
	Thermostat	Nest Digital - T-Stat	

Detail of requirements

If Heat Pump is installed outside will need to Run New Thermostat wire from Air Handler to Heat Pump.

- ① 3-ton Air Handler & Heat Kit
- ② New Supply & Return Air Plenums
- ③ Increase Return Air Grill from 20" x 20" to 25" x 30" Return
- ④ Run New Thermostat wire to outside unit
- ⑤ Install New 3-ton Heat Pump & New Pad outside
- ⑥ Cut Sheet Rock in order to Access Air Handler in Attic





469-449-8898
LIFE SUPPORT

WATERLOO
AIR CONDITIONING
578-8458

GOODMAN MANUFACTURING CO. P.
HOUSTON, TEXAS 77008

MODEL DX24-1B
SERIAL NO. 0001533961
A.C. VOLTS 208/230 PHASE 3 HERTZ 60
VOLTAGE RANGE MIN. 197 MAX. 208
MIN. CIRCUIT AMPS 16.4
MAX. FUSE AMPS OR HACR TYPE CIRCUIT BREAKER
(HACR CIRCUIT BREAKER FOR U. S. ONLY) RLA 12.1 LRA 5
COMPRESSOR FLA 1.3
MAX. WORKING PRESSURE 71
FAN MOTOR
FACTORY CHARGE OZ: R22 LOW
FACTORY TEST PRESSURE PSIG

HEATING
AND COOLING
EQUIPMENT

CAUTION
DISCONNECT THE ELECTRICAL
BEFORE SERVICING.
ATTENTION:
DECONNECTER DU CIRCUIT
ELECTRIQUE AVANT L'ENTRETIEN
USE COPPER CONDUCTORS ONLY
THIS EQUIPMENT SUITABLE FOR



CENTRAL
COOLING AIR
CONDITIONER
G0182770080

CE

MEAN NO. _____
ACCEPTED FOR USE

PART NO. _____

SCOPE OF WORK REQUIRED – CITY OF LEWISVILLE

Address: [REDACTED]

System Repair

Partial Install

Full System replacement

Summary of requirements to restore to operation & bring to code

Recommendations

- ① Install a New Filter Base, 3.5 ton Air Handler & 15KW Heat Kit.
No Electrical Disconnect in Closet. Will need to install Elec. Disconnect for A/H.
 - ② Install New outdoor Condensing Unit also, unit over 15yrs. old. Flat. No Refrig.
- Overview of diagnostic findings HVAC System is over 15 years old, R-22 Refrigerant. Will need to Flush Refrig. Lines to Convert to New Refrigerant.

Current equipment – Model & Serial

	Model #	Serial #
Outdoor	Carrier (24ABR342A0031010)	[REDACTED]
Air handler/ Furn	EPCO E44-168384	[REDACTED]
Evaporator	N/A	[REDACTED]
Thermostat	Magic Star	[REDACTED]

Detail of requirements

A. A. S. Recommendation is to replace the whole HVAC System due to age and needed repairs. Will also need to replace the Thermostats in Hallway.

- ① 3.5 ton Air Handler, Heat Kit Assembly.
- ② 3.5 ton Straight Cool outdoor Condenser
- ③ Air Filter Base in Utility Closet & Electrical Disconnect Box
- ④ Thermostat in Hallway Area.



ELECTRIC PRODUCTS

MFG. CORP.

MESQUITE, TEXAS

SERIAL NO. **E44-168381**

MODEL NO. **F20-K-04-20-09**

BTU **69,600** AT **240** VOLTS 60 HZ **1** PHASE. THIS

UNIT PRODUCES **1,600** CFM AT **0.50** IN. EXTERNAL STAT

PRESSURE. ELEMENT AMPS: (A) L1 **89** L2 **89** L3

(B) L1 L2 L3 (C) L1 L2 L3 L4

L5 & L6 L7 & L8 (D)

FAN **1/3** HP **1** PHASE **240** VOLTS **4.4** AMPS

FAN CIRCUIT F1 & F2 **5** AMPS

MAXIMUM AIR OUTLET TEMPERATURE LESS THAN 200°F. WHEN INSTALLING THE UNIT IN THE COUNTER FLOW POSITION ON A COMBUSTIBLE FLOOR, USE SUB-BASE MODEL NO. **E20-** THIS UNIT APPROVED FOR THE FOLLOWING CLEARANCES: SIDE AND BACK 0, RETURN AND SUPPLY PLENUMS 1". ALLOW 24" FOR SERVICING, SEE INSTALLATION MANUAL FOR SPECIFIC INSTALLATION REQUIREMENTS.

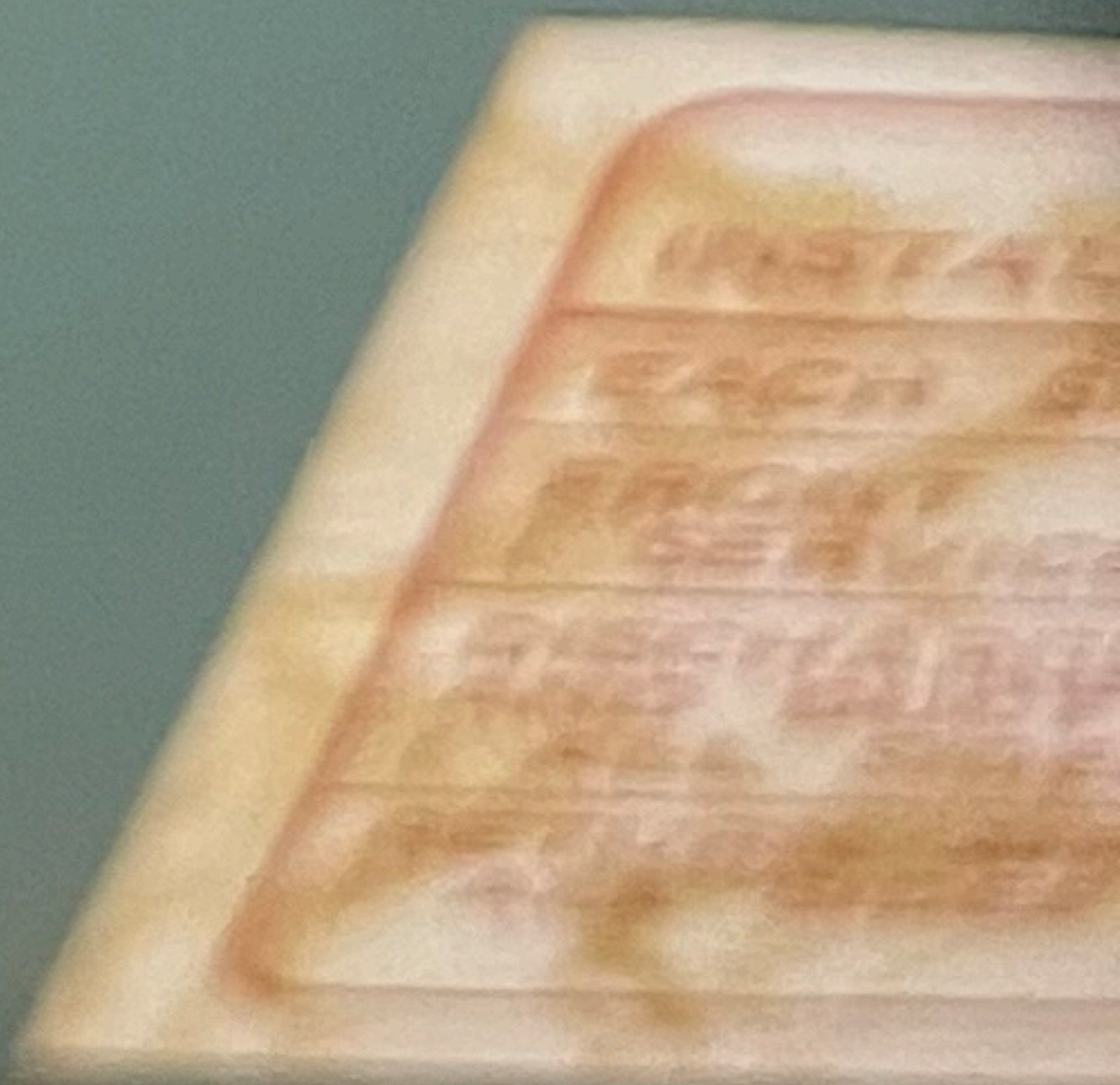
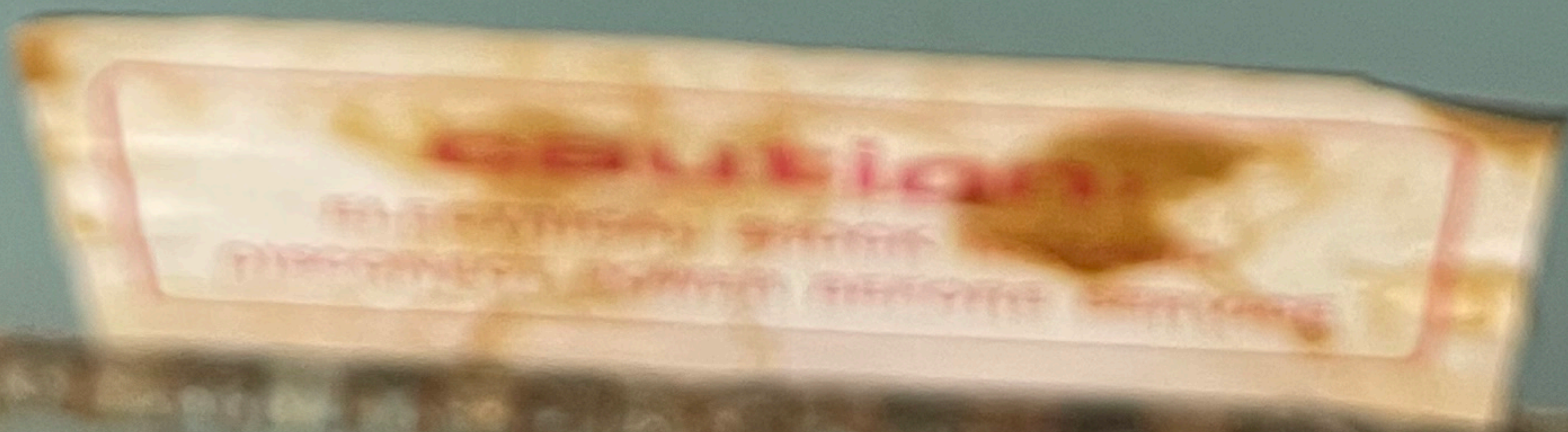
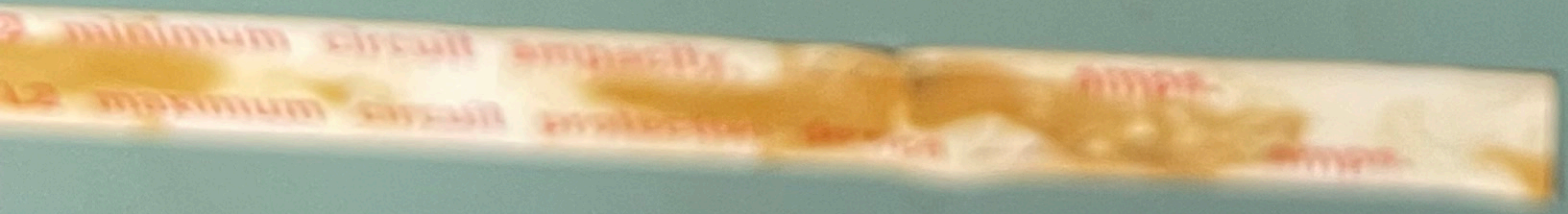
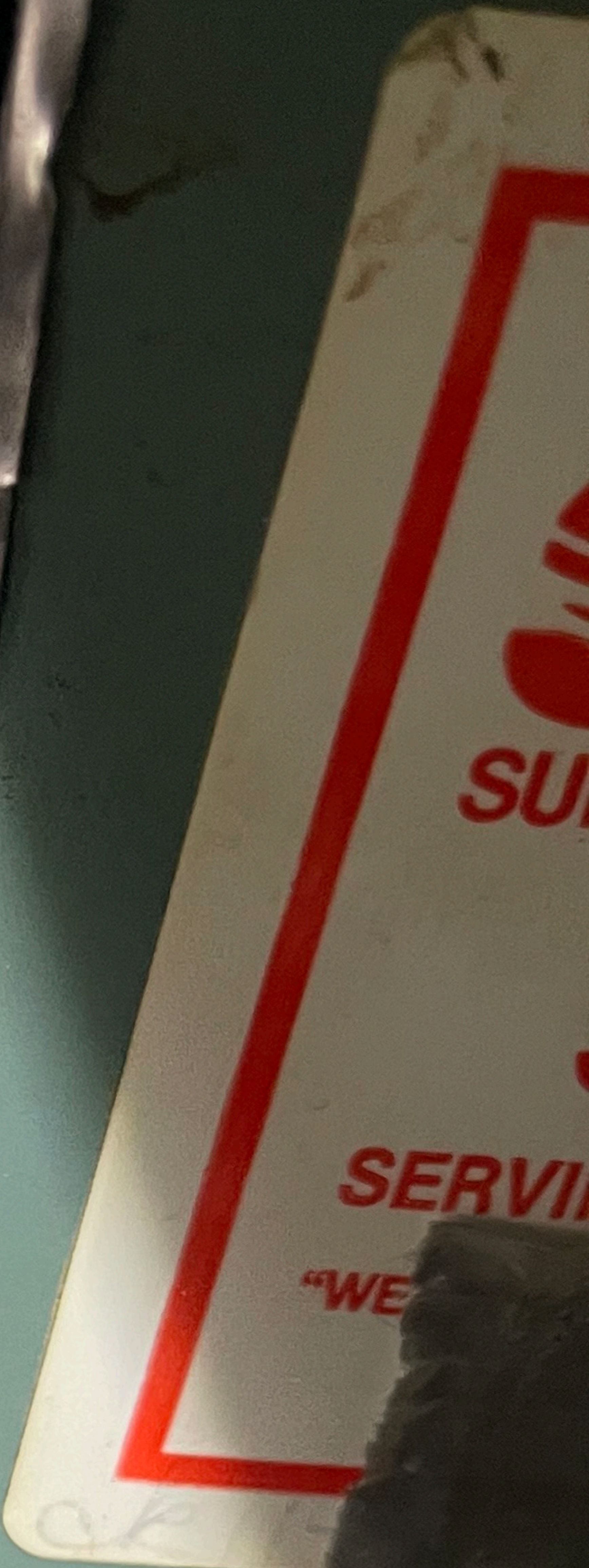

24A LISTED 82P4

LISTED 181A-P

NO. 101-101-101

21427729
METAL-PAK, INC.
Houston, Texas

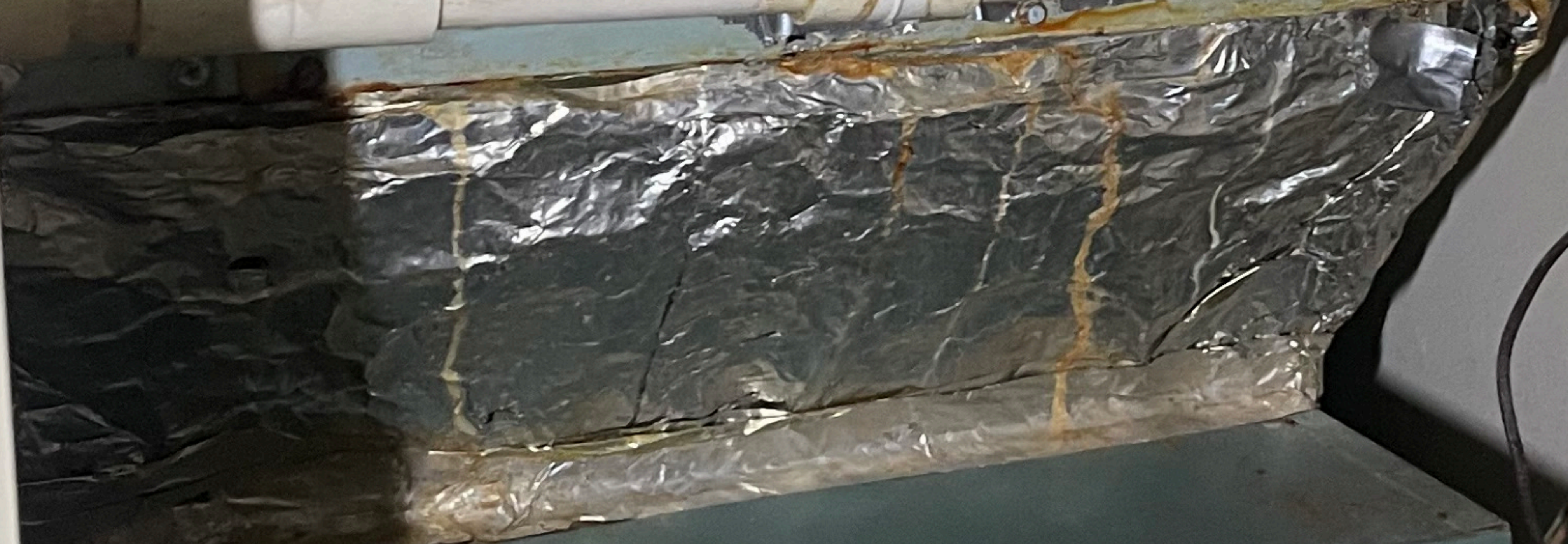

ELECTRIC PRODUCTS
MFG. CORP.
WILSON, TEXAS

CALL OUR SERVICE DEPARTMENT
SUN-AP
SUN AIR CONDITIONING INC.
956-9151
SERVING DALLAS AREA

CAUTION
ELECTRICAL SHOCK
DISCONNECT POWER BEFORE SERVING

TEST EQUIPMENT	CLEARANCE
1. VOLTAGE	24 INCHES
2. CURRENT	36 INCHES
3. POWER	48 INCHES
4. FREQUENCY	60 INCHES
5. PHASE	72 INCHES
6. AMPLITUDE	84 INCHES
7. DURATION	96 INCHES
8. TEMPERATURE	108 INCHES
9. HUMIDITY	120 INCHES
10. VIBRATION	132 INCHES





SERIAL 1007E08260

PROD 24ABR342A0031010

MODEL 24ABR342A310

METERING TXU N/A
DEVICE INDOOR OUTDOOR

FACTORY CHARGED R-22
7.15 LBS 3.24 KG

INDOOR TXU SUB COOLING 11 °F

POWER SUPPLY 208-230 VOLTS AC
1 PH 60 HZ

PERMISSIBLE VOLTAGE AT UNIT
253 MAX 197 MIN

SUITABLE FOR OUTDOOR USE

COMPRESSOR 208/230 VOLTS AC
1 PH 60 HZ
19.2 RLA 104.0 LRA

FAN MOTOR 208/230 VOLTS AC
1 PH 60 HZ
1/4 HP 1.4 FLA

DESIGN/TEST PRESSURE GAGE
HI 300 PSI 2068 KPA
LO 150 PSI 1034 KPA

MAX DESIGN/WORKING PRESSURE
700 PSIG 4826 KPA

MINIMUM CIRCUIT AMPS 25.4
MAX FUSE 40 A MAX CKT-BKR(*) 40 A
* HACR TYPE RECOMMENDED

MODEL NUMBER 24ABR342A0031010

SERIAL NUMBER 1007E08260

LISTED SECTION OF
CENTRAL COOLING
AIR CONDITIONER
3630

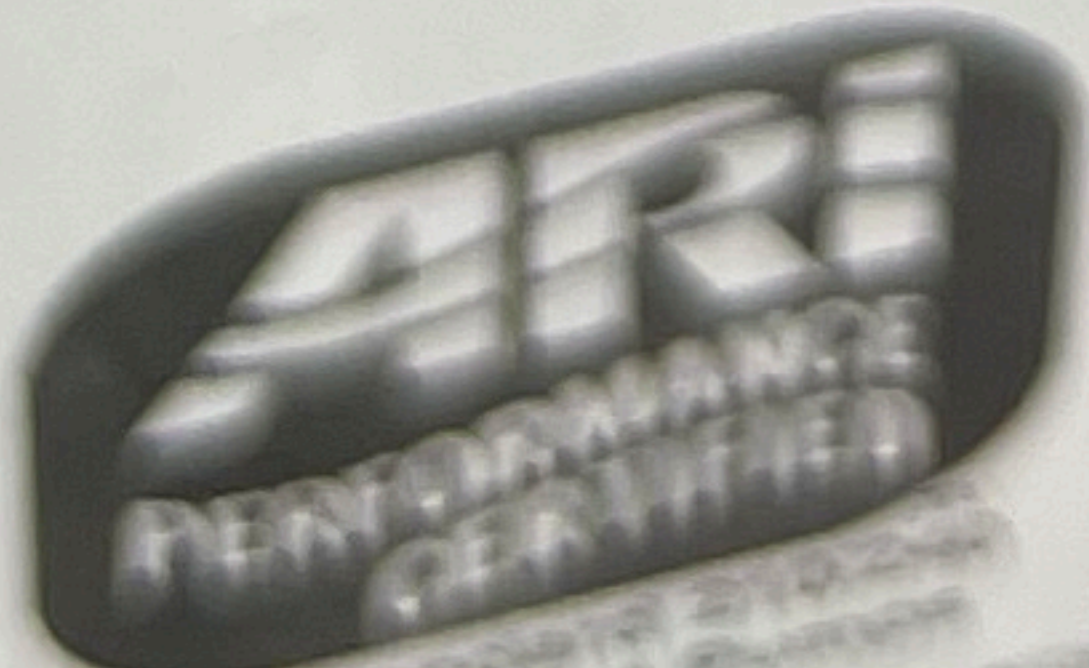

SCOPE OF WORK REQUIRED – CITY OF LEWISVILLE

Address: [REDACTED]

System Repair

Partial Install

Full System replacement

Summary of requirements to restore to operation & bring to code Recommendation are to

Replace both the Downstairs & upstairs HVAC Systems.

The Downstairs A.C. System is undersized. Both A.C. Systems are 18 years old. In addition, the Downstairs A.C. System has a non-repairable Refrigerant leak.

Overview of diagnostic findings The Downstairs unit is undersize & has a Refrigerant leak. Both Air Handlers & Outside Condensing units are Old and inefficient.

Current equipment – Model & Serial

	Model #	Serial #
Outdoor Goodman	GLBN24	Label Not Legible
Outdoor Goodman	GLBN180	Label is Not Legible
Air handler/ Furn Goodman	ARUFO24-DDA-1	[REDACTED]
Air handler/ Furn Goodman	ARUFO18-DDA-1	[REDACTED]
Evaporator	N/A	
Thermostat	Digital Thermostats	

Detail of requirements

A.A.S. Recommendations are to install two New HVAC Systems. Replace both Electrical Whips on the Outside Condensing Units.

① 1.5 ton A-Cabinet Air Handler w/15KW Heat PKG & Outside Condenser for the upstairs Zone need to replace Air Filter Base in Closet.

② 2.5 ton B-Cabinet Air Handler with 15KW Heat Kit & outside Condensing Unit, also need New Air Filter Base in Utility Closet

Both Air Handlers & outside Condensing Units are over 18 years Old.

MODEL NO. ARUF018-00A-1

SERIAL NO. 0405144093

MOTOR	
AMP	H/P
0.96	1/5

TEST EXTERNAL STATIC PRESSURE (INCHES) **0.2** MAXIMUM OUTLET TEMPERATURE 200°F.
 OR LESS. 0 INCH CLEARANCE FROM CABINET, PLENUM AND DUCT. FOR INSTALLATION,
 SEE MANUAL CABINET INSULATION R-VALUE=4.2

PART NO. **14310-00**

208/240 VOLTS

60 HERTZ

1 PHASE

WHEN INSTALLING ONE OF THE ACCESSORY HEAT KITS, PERMANENTLY IDENTIFY THE MODEL ON THIS PLATE.

MARK HERE	HEATER KIT MODEL USED	CIRCUIT 1			CIRCUIT 2		
		H.A.	M.C.A.	M.O.P.	H.A.	M.C.A.	M.O.P.
	NO HEAT KIT	0/0	1.2/1.2	15/15			
	W/ HKR-03	10.8/12.5	15/17	20/20			
	W/ HKR-05(C)	17.1/19.8	23/26	30/30			
	W/ HKR-06	21.6/25.0	29/33	40/40			
	W/ HKR-08(C)	25.2/29.1	33/38	40/40			

* CIRCUIT 1: SINGLE PHASE FOR AIRHANDLER
 CIRCUIT 2: THREE PHASE FOR HKR3 HEATER KIT

H.A.=HEATER AMPS
 M.C.A.=MINIMUM CIRCUIT AMPS
 M.O.P.=MAXIMUM OVERCURRENT PROTECTION

WARNING: HAZARD OF ELECTRIC SHOCK. DISCONNECT ALL POWER BEFORE REMOVING THIS PANEL. MORE THAN ONE DISCONNECT WILL BE REQUIRED TO DE-ENERGIZE EQUIPMENT SUPPLIED BY MORE THAN ONE BRANCH CIRCUIT.

ADVERTENCIA: PELIGRO DE CHOQUE ELÉCTRICO. DESCONECTE EL SUMINISTRO ELÉCTRICO ANTES DE SACAR ESTE PANEL. ES NECESARIO DESCONECTAR MÁS DE UNA CONEXIÓN PARA DESELECTRIFICAR EQUIPO ALIMENTADO POR MÁS DE UN RAMAL DE CIRCUITO.

AVERTISSEMENT: DANGER D'ELECTROCUTION. D'EBRANCHER TOUTES LES ALIMENTATIONS AVANT D'ENLEVER CE PANNEAU. PLUS D'UN DEBRANCHEMENT EST NÉCESSAIRE POUR METTRE HORS CIRCUIT L'EQUIPEMENT QUI EST ALIMENTÉ PAR PLUS D'UNE DÉRIVATION.

CAUTION: NOT SUITABLE FOR USE ON SYSTEMS EXCEEDING 150V TO GROUND
 ATTENTION: NE CONVIENT PAS AUX INSTALLATIONS DU PLUS DE 150V A LA TERRE



HEAT PUMP/AIR
 CONDITIONER
 SECTION



GOODMAN MANUFACTURING CO., L. P.
HOUSTON, TEXAS 77008

MODEL _____ HERTZ
SERIAL NO. _____
A.C. VOLTS _____
VOLTAGE RANGE _____
MIN. CIRCUIT AMPS _____
MAX. FUSE AMPS OR HACR TYPE CIRCUIT BREAKER _____
(HACR CIRCUIT BREAKER FOR U.S. ONLY)
COMPRESSION PRESSURE _____
MAX. WORKING PRESSURE _____
FAN MOTOR _____
FACTORY CHARGE OZ. R22 _____
FACTORY TEST PRESSURE PSIG _____

CAUTION: DISCONNECT THE ELECTRICAL POWER BEFORE SERVICING.
ATTENTION: DECONNECTER DU CIRCUIT D'ALIMENTATION ELECTRIQUE AVANT L'ENTRETIEN.
USE COPPER CONDUCTORS ONLY
THIS EQUIPMENT SUITABLE FOR OUTDOOR USE



HEATING AND COOLING EQUIPMENT

CENTRAL COOLING AIR CONDITIONER
60182770080

MEAS. NO. _____
ACCEPTED FOR USE
CITY OF NEW YORK

PART NO. _____

Parker

White Out - Blue
Red Unit - Brown
Y-W
E-B
R-H

This filter can also be installed in wall & ceiling returns

Instructions
This filter can be installed in wall & ceiling returns. To install, simply slide the filter into the return until it clicks into place. For more information, please refer to the instructions that came with the filter.

Maintenance Schedule
Call 1-800-875-2212 for customer service

Installation Date:	9-18-08
Cleaned Date:	
Cleaned Date:	
Cleaned Date:	
Cleaned Date:	
Cleaned Date:	
Cleaned Date:	
Cleaned Date:	
Cleaned Date:	
Cleaned Date:	
Cleaned Date:	

Limited Lifetime Warranty
Any filter found to be defective in workmanship or materials will be replaced or repaired at no charge of purchase date and original date of the filter. This warranty will be void if the filter is not installed in accordance with the instructions. Regular cleaning is required to maintain this warranty.

Important: Please complete and return the registration form to the manufacturer to activate your warranty.

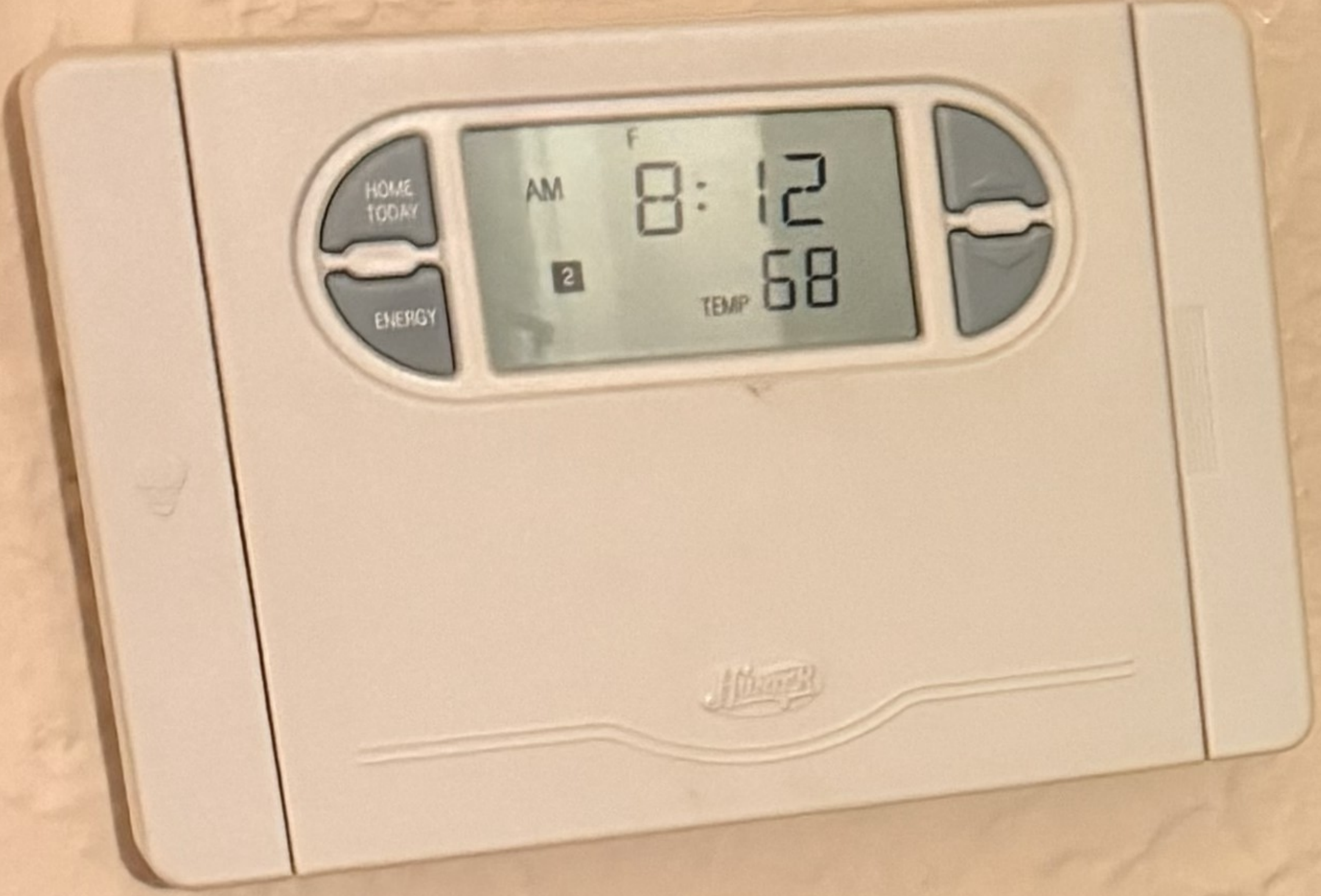

Based on standard U.S. Government test
ENERGYGUIDE
Compare the Energy Efficiency of this Furnace with Others Before You Buy.

This Model's Energy Efficiency Ratio (EER) is 13.0

Energy efficiency range of all similar models:
Lowest EER: 12.0
Highest EER: 13.0

The AFUE, Annual Fuel Efficiency, is the measure of energy efficiency for furnaces and boilers. Only furnaces utilizing electricity are used in this table.

Furnace use requires the user to follow all the instructions for use, installation, and operation. Read the instructions for use, installation, and operation. Look for the information on the efficiency and operating cost of the equipment.

WARNING
DANGER
Read the instructions for use, installation, and operation. Look for the information on the efficiency and operating cost of the equipment.

Model No. 98R-P22B-020-1

Model No.	Model No.	Model No.	Model No.	Model No.
98R-P22B-020-1	98R-P22B-020-2	98R-P22B-020-3	98R-P22B-020-4	98R-P22B-020-5
98R-P22B-020-6	98R-P22B-020-7	98R-P22B-020-8	98R-P22B-020-9	98R-P22B-020-10
98R-P22B-020-11	98R-P22B-020-12	98R-P22B-020-13	98R-P22B-020-14	98R-P22B-020-15
98R-P22B-020-16	98R-P22B-020-17	98R-P22B-020-18	98R-P22B-020-19	98R-P22B-020-20

INSTALLATION NOTE
ALL DRAIN PIPING CONNECTIONS TO BE MADE THROUGH THE EXTERIOR WALL. ALL DRAIN PIPING SHOULD BE MADE THROUGH THE EXTERIOR WALL. ALL DRAIN PIPING SHOULD BE MADE THROUGH THE EXTERIOR WALL.





SCOPE OF WORK REQUIRED – CITY OF LEWISVILLE

Address:



System Repair

Partial Install

Full System replacement

Summary of requirements to restore to operation & bring to code

Customer stated

the upstairs area gets very hot during the summer months.

Needs a zoning system installed on existing HVAC system.

Overview of diagnostic findings

Install a zoning board, thermostat for

the upstairs zone in house

HVAC is approx 6 yrs. appears to be in good condition.

Current equipment – Model & Serial

Outdoor

Carrier CA16NA048-B

Air handler/Furn
Carrier

FB4CNF048

Evaporator

N/A

Thermostat

model #

Serial #

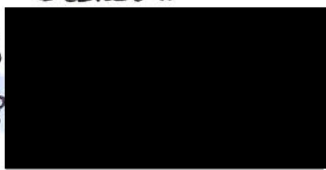

Detail of requirements

A. A. S. Recommendations are to install a zoning board, thermostat & necessary wiring to the existing HVAC system.

ADVERTENCIA

313824-201 REV B



313824-201 REV B



⚠ WARNING ⚠ AVERTISSEMENT

ELECTRICAL SHOCK HAZARD
RISQUE DE ELECTROCUTION

ATTENTION: RISK OF DECHARGE ELECTRIQUE

RISK OF ELECTRIC SHOCK CAN CAUSE INJURY OR DEATH. DISCONNECT ALL REMOTE ELECTRIC POWER SUPPLIES BEFORE SERVICING.

POUVANT CAUSER DES BLESSURES OU LA MORT. DECONNECTER TOUTES LES ALIMENTATIONS ELECTRIQUES AVANT L'ENTRETIEN

313824-201 REV B

CAC/80P
 7810 W. Merck
 Indianapolis, IN
 46257-4708
**ENGINEERS
 ASSEMBLED**

CAUTION ⚠ ATTENTION

EXPLOSION HAZARD / RISQUE D'EXPLOSION

system under pressure. Relieve all pressure and recover refrigerant before system repairs or final disposal. Use all service ports. *Le système sous pression. Relâchez toutes pressions et récupérer le réfrigérant avant d'entreprendre les travaux d'entretien ou de réparation finale du produit. Utilisez tous les ports de maintenance.*

FIRE HAZARD / RISQUE DE FEU

Do not use torch to remove components. Oil may catch fire. Use tubing cutter. *N'utilisez pas la torche pour retirer les composants. L'huile peut prendre feu. Utilisez une coupe-tube.*

NOTICE / AVIS

BEFORE REPLACING TV, COMPLETE THESE STEPS:

1. Verify airflow is correct.
2. Check evaporator at outdoor unit is properly attached and insulated.
3. Confirm TXV coils are properly attached and insulated.
4. Verify system is free of contaminants and moisture.
5. Do not evaporator and condenser coils are clean.

Detailed troubleshooting instructions are available in the service manual.

AVANT DE REMPLACER LE TV, BIEN SUIVRE LES ÉTAPES

1. Vérifier si le débit d'air est correcte.
2. Vérifier si l'évaporateur est correctement attaché et isolé.
3. Vérifier si les bobines TXV sont correctement attachées et isolées.
4. Vérifier que le système est libre de contaminants et d'humidité.
5. Assurer que l'évaporateur et le condenseur sont propres.

Une chaîne de détails est disponible dans le manuel de service.

INSTALLATION / INSTALLATION

UNIT REQUIRES THE FOLLOWING FOR PROPER OPERATION:

 1. Level unit and to clear, unit to be installed with primary and secondary drain lines. PVC fittings should be used with sealant.
 2. Verify that the drain lines are clear to unit as possible. Use 1/2" traps. Pitch line 1" per 10'.
 3. Do not use motor speed tap directly for installation instructions and unit pre-sale program.
 4. Do not use the drain pan (not for use with 200V unit or 6 ton units) with cause leakage.
 5. Do not use the drain pan (not for use with 200V unit or 6 ton units) with cause leakage.
 6. Do not use the drain pan (not for use with 200V unit or 6 ton units) with cause leakage.

SEE INSTALLATION INSTRUCTIONS FOR ADDITIONAL INFORMATION ON THESE AND OTHER SUBJECTS.

POUR UN FONCTIONNEMENT NORMAL, L'UNIT A BESOIN DE :

 1. Mettre l'unité à niveau et à être installé avec des raccords de PVC.
 2. Vérifier que les lignes d'évacuation des condensats primaires et secondaires sont claires et que les raccords de PVC sont utilisés avec du mastic.
 3. Vérifier que les lignes d'évacuation des condensats sont claires et que les raccords de PVC sont utilisés avec du mastic.
 4. Ne pas utiliser le tap de vitesse du moteur directement pour l'installation et les instructions de pré-vente de l'unité.
 5. Ne pas utiliser le bac à égouttoir (non prévu pour les unités de 200V ou les unités de 6 tonnes) avec une cause de fuite.
 6. Ne pas utiliser le bac à égouttoir (non prévu pour les unités de 200V ou les unités de 6 tonnes) avec une cause de fuite.

VOIR LES INSTRUCTIONS D'INSTALLATION POUR TOUTES LES MÉTHODES ET AUTRES SUJETS.

⚠ WARNING ⚠

SERVICE / ENTRETIEN

Service of this equipment may damage the plastic pan. Please use care when servicing and always use proper techniques. See service manual for proper techniques. *Le service de cet équipement peut endommager le plateau de plastique. Veuillez faire attention lors de l'entretien. Utilisez des techniques appropriées. Voir le manuel de service pour les techniques appropriées.*





313824-201 REV B

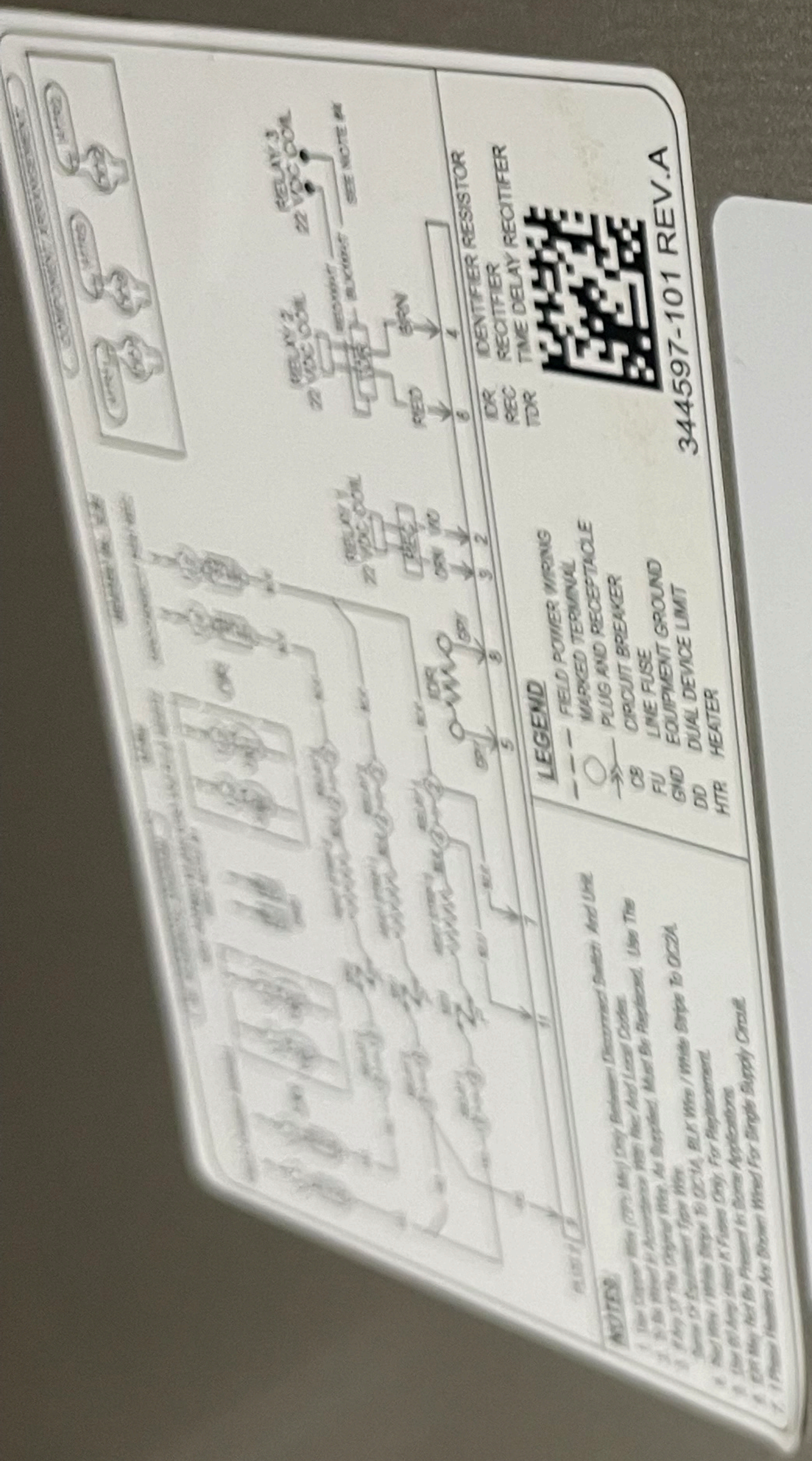



344597-101 REV.A

 FB4CNF048L00E1AA
 2020F30349
 PRODUCT NO. FB4CNF048L00E1AA
 MODEL NO. FB4CNF048
 SERIAL NO. 2020F30349
 VOLTS 208/230
 MOTOR HP 3/4
 MOTOR FLA 6
 PHASE/HERTZ 1/60
 TEST STATIC 0.2 IN. W.C.
 REFRIGERANT 410A DESIGN PSIG 450
 DATE OF MANUFACTURE MAY 2020

INSTALLER: APPLY THIS INFORMATION PLATE OVER SPACE INDICATED ON DOOR RATING PLATE. SEE INSTALLATION INSTRUCTIONS FOR 1" CLEARANCE REQUIREMENTS

DUAL	HEATER AMPS SUPPLY CIRCUIT	MAX. OVERCURRENT PROTECTION	MIN. AMPACITY
L1/L2	HEATER AMPS	36.2/40.0	MIN. AMPACITY 53.8/58.5
L3/L4	HEATER AMPS	18.1/20.0	MIN. AMPACITY 22.7/25.0
HEAT PACKAGE IN THIS UNIT			MAX. OVERCURRENT PROTECTION 26/26

L1/L2 HEATER AMPS	MAX. OVERCURRENT PROTECTION	MIN. AMPACITY
0	15	7.5
L1/L2 HEATER AMPS	DUAL SUPPLY CIRCUIT	N/A
N/A	N/A	N/A
L3/L4 HEATER AMPS	N/A	N/A
N/A	N/A	N/A

HEAT PACK INSTALLED N/A
 UNIT HAS INTEGRAL LIMIT CONTROL. MAX. OUTLET TEMP. 100F
 MOTOR ELECTRONICALLY PROTECTED.
 SEE INSTALLATION INSTRUCTIONS FOR SPECIFIC INSTALLATION REQUIREMENTS AND APPROVED ACCESSORY KIT INFORMATION.
 MAX. VOLTAGE TO GROUND OF SUPPLY CIRCUIT NOT TO EXCEED 120 VOLTS IF HEATER COIL FOR COOLING ONLY EXCEPT WHEN INSTALLED AS PART OF SECTION AND FROM FOUNDATION CLEARANCE.

SHORIT CIRCUIT CURRENT: 5KA RMS, SYMMETRICAL, 230 V
 LABEL P/N 324648-443 REV. A

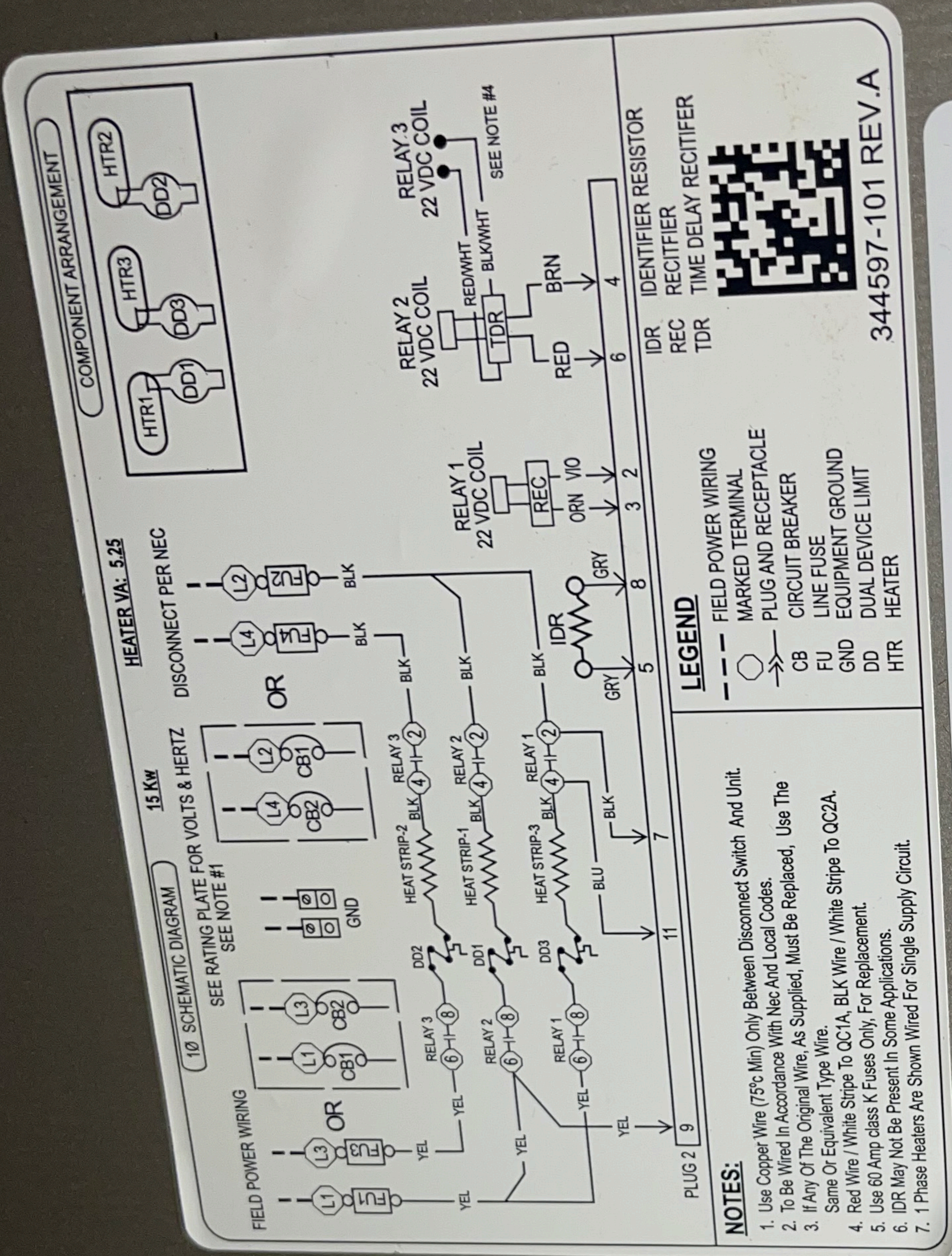

PRODUCT NO.	FB4CNF048L00E1AA
MODEL NO.	FB4CNF048
SERIAL NO.	2020F30349
VOLTS	208/230
MOTOR HP	3/4
MOTOR FLA	6
PHASE/HERTZ	1/60
TEST STATIC	0.2 IN. W.C.
REFRIGERANT	410A DESIGN PSIG 450
DATE OF MANUFACTURE	MAY 2020



INSTALLER: APPLY THIS INFORMATION PLATE OVER SPACE INDICATED ON DOOR RATING PLATE. SEE INSTALLATION INSTRUCTIONS FOR 1" CLEARANCE REQUIREMENTS

SUPPLY CIRCUIT	VOLTS	208/230	PHASE	1
HEATER AMPS SUPPLY CIRCUIT	MAX. OVERCURRENT PROTECTION	MIN. AMPACITY		
L1/L2	36.2/40.0	53.8/58.5		
L3/L4	18.1/20.0	60/60		
HEATER AMPS	MAX. OVERCURRENT PROTECTION	MIN. AMPACITY		
L1/L2	18.1/20.0	22.7/25.0		
L3/L4	MAX. OVERCURRENT PROTECTION	25/25		

HEAT PACKAGE IN THIS UNIT KFCEH3101C15B LABEL P/N 324648-443 REV. A

L1/L2 HEATER AMPS	0	MIN. AMPACITY	7.5
MAX. OVERCUR. PROTECTION	15	DUAL SUPPLY CIRCUIT	
L1/L2 HEATER AMPS	N/A	MIN. AMPACITY	N/A
MAX. OVERCUR. PROTECTION	N/A	MIN. AMPACITY	N/A
L3/L4 HEATER AMPS	N/A	MIN. AMPACITY	N/A
MAX. OVERCUR. PROTECTION	N/A	MIN. AMPACITY	N/A

SERIAL	1220X45770		
PROD	CA16NA04800GABBA		
MODEL	CA16NA048 - B		
METERING	TXV	N/A	
DEVICE	INDOOR	OUTDOOR	
FACTORY CHARGED	R-410A		
	13.00	LBS	5.90 KG
INDOOR TXV SUB COOLING	8		°F
POWER SUPPLY	208 - 230		VOLTS AC
	1	PH	60 HZ
PERMISSIBLE VOLTAGE AT UNIT			
	253	MAX	197 MIN
SUITABLE FOR OUTDOOR USE			
COMPRESSOR	208/230		VOLTS AC
	1	PH	60 HZ
	19.90	RLA	109.0 LRA
FAN MOTOR	208/230		VOLTS AC
	1	PH	60 HZ
	1/4	HP	1.20 FLA
DESIGN / TEST PRESSURE GAGE			
HI	450	PSI	3103 KPA
LO	250	PSI	1724 KPA
MAX DESIGN / WORKING PRESSURE			
	700	PSIG	4826 KPA
MINIMUM CIRCUIT AMPS			
	26.1		
MAX FUSE	40	A	MAX CKT - BKR 40 A
Short Circuit Current : 5 kA rms, symmetrical.			230 V

MODEL NUMBER

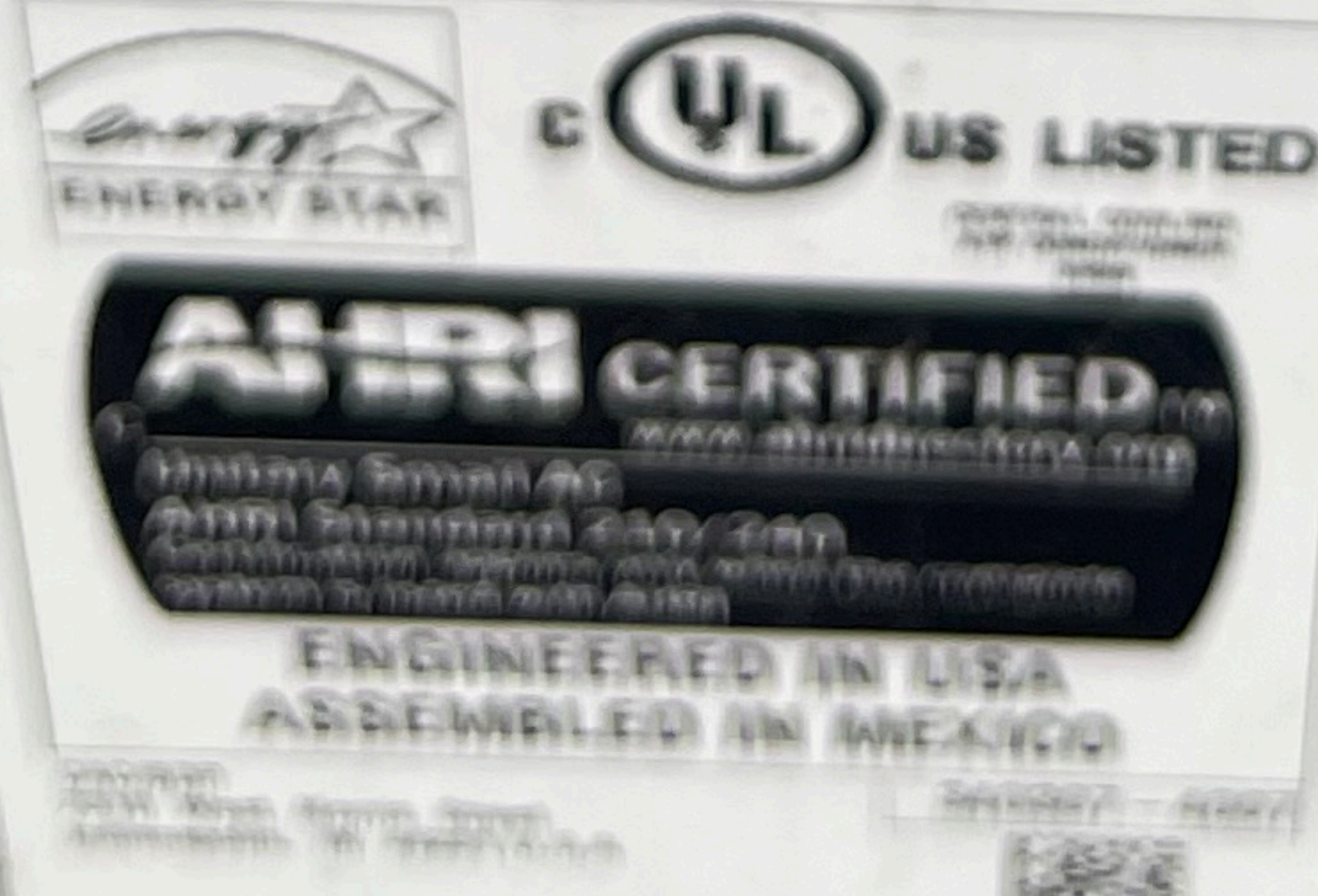
 SERIAL NUMBER

 DATE OF MANUFACTURE: Mar-2020



Installation Prohibited in Southwest

⚠ WARNING

This product can expose you to chemicals including Lead and lead compounds, which are known to the State of California to cause cancer and birth defects or other reproductive harm. For more information go to www.P65Warnings.ca.gov.

⚠ AVERTISSEMENT

Ce produit peut vous exposer à des agents chimiques, y compris le plomb et les composés de plomb, identifiés par l'État de Californie comme pouvant causer le cancer et des malformations congénitales ou autres troubles de l'appareil reproducteur. Pour de plus amples informations, allez de consulter www.P65Warnings.ca.gov.

⚠ ADVERTENCIA

Este producto puede exponerle a químicos que incluyen plomo y compuestos de plomo, los cuales son conocidos en el Estado de California como causantes de cáncer y defectos de nacimiento, o otros daños reproductivos. Para mayor información, visite www.P65Warnings.ca.gov.

24-0004-201 REV A

WARNING
ELECTRICAL SHOCK HAZARD
WARNING: ANY ELECTRICAL
WORK SHOULD BE DONE BY A
LICENSED ELECTRICIAN. DO NOT
REMOVE COVER OR REFRIGERANT
TUBING WITHOUT THE ASSISTANCE
OF A LICENSED REFRIGERATION
TECHNICIAN.
AVERTISSEMENT
DANGER DE CHOC ELECTRIQUE
ATTENTION: NE PAS FAIRE DE
TRAVAIL ELECTRIQUE SANS L'AIDE
D'UN ELECTRICIEN LICENCIE.
NE PAS ENLEVER LE COUVERCLE
NI LES TUYAUX DE REFRIGERANT
SANS L'AIDE D'UN TECHNICIEN
LICENCIE EN REFRIGERATION.

MODEL 1220X45770
PART CATENAD45770A
SERIAL 13.800
TYPE TVI
REGION N/A
FACTORY CHARGE 5.90
POWER SUPPLY 208-230V 60Hz
POWERED BY WIRING AT THE
RATED FOR OUTDOOR USE
COMPRESSOR 208/230V 60Hz
THERMOSTAT 60 Hz
FAN MOTOR 208/230V 60Hz
1/4 HP 1.00 P.A.
SEASON 7000 PRESSURE 28.1
HI 450 PSI 3100 kPa
LO 250 PSI 1724 kPa
MAXIMUM WORKING PRESSURE 700 PSI 4826 kPa
WARRANTY PERIOD 24 MONTHS
DATE OF MANUFACTURE 04-10-2010
UL LISTED
ENERGY STAR
A/C CERTIFIED
Installation Prohibited in Southwest

WARNING
This product can expose you to chemicals including
lead and lead compounds which are known to the
State of California to cause cancer and birth defects
or other reproductive harm. For more information go
to www.P65Warnings.ca.gov

AVERTISSEMENT
Ce produit peut vous exposer à des agents
cancérogènes ou susceptibles de provoquer des
défauts de naissance, y compris le plomb et les
composés du plomb, qui sont connus par l'état de
la Californie de causer le cancer, des défauts de
naissance ou d'autres problèmes de reproduction.
Pour plus d'informations, visitez le site internet
www.P65Warnings.ca.gov

ADVERTENCIA
Este producto puede exponerle a químicos,
incluyendo plomo y compuestos de plomo, que
según el estado de California son conocidos por
causar cáncer, defectos de nacimiento y otros
problemas reproductivos. Para mayor información,
visite el sitio web www.P65Warnings.ca.gov

DESIGN / TEST PRESSURE GAGE

HI	450	PSI	3103	KPA
LO	250	PSI	1724	KPA

MAX DESIGN / WORKING PRESSURE

700 PSIG 4826 KPA

MINIMUM CIRCUIT AMPS 26.1

MAX FUSE 40 A MAX CKT - BKR 40 A

Short Circuit Current : 5 kA rms, symmetrical, 230 V

MODEL NUMBER



CA16NAB04800GABBA

SERIAL NUMBER



1220X45770

DATE OF MANUFACTURE: Mar - 2020

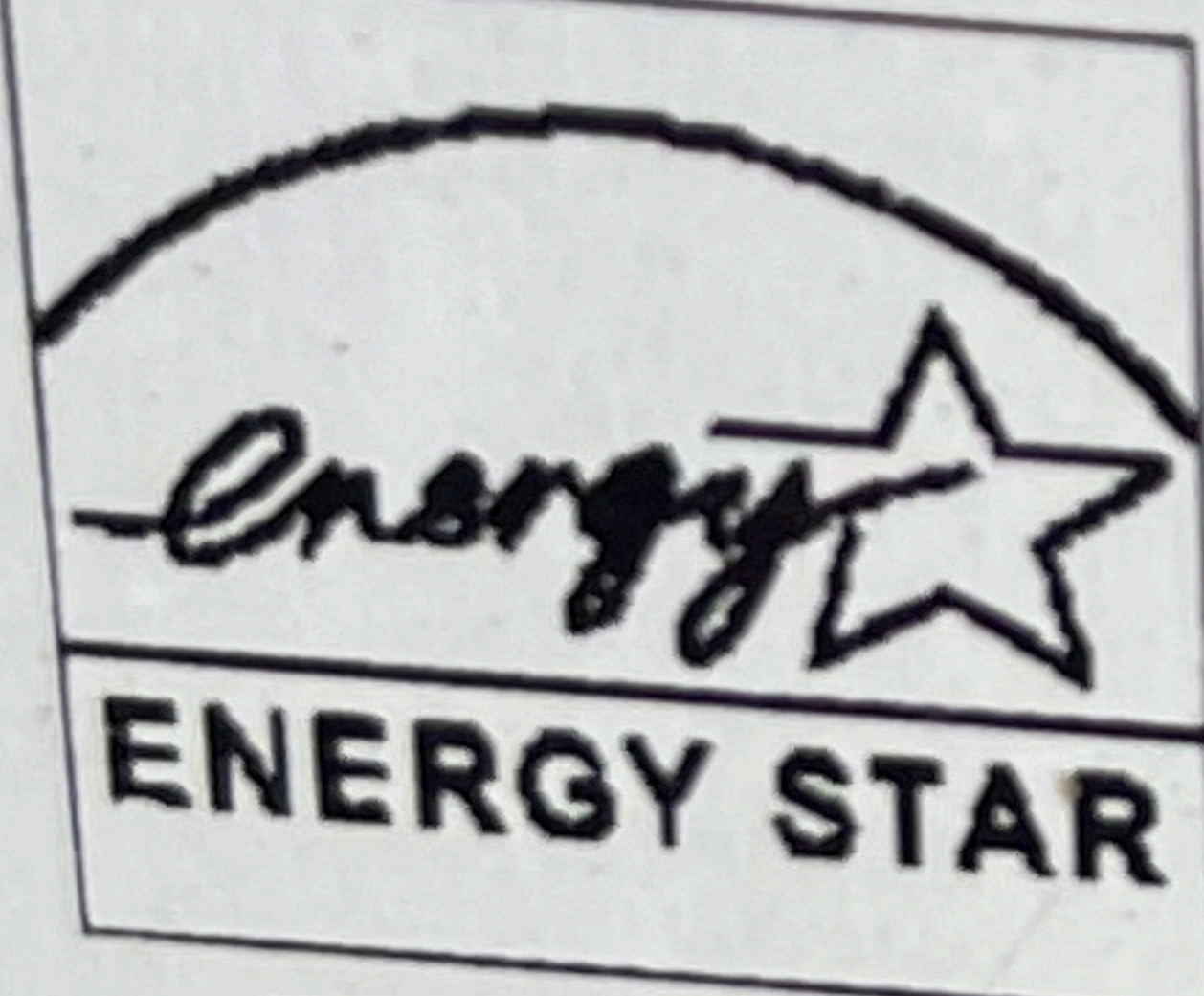

CENTRAL COOLING AIR CONDITIONER 3R39



Unitary Small AC AHRI Standard 210/240 Certification applies only when the complete system is listed with AHRI

ENGINEERED IN USA ASSEMBLED IN MEXICO

CAC/BDP 7310 West Morris Street Indianapolis, IN 46231 U.S.A

340307-4007



Installation Prohibited in Southwest

This product contains Lead and other hazardous materials. For more information, visit the State of California Department of Pesticide Regulation website at www.P65Warnings.ca.gov



Ce produit peut contenir des substances chimiques, y compris du plomb, identifiées comme étant susceptibles de provoquer des dommages congénitaux ou reproductifs. Pour plus d'informations, veuillez consulter le site internet du Département de la Régulation des Pesticides de l'état de Californie à www.P65Warnings.ca.gov



Este producto puede contener sustancias químicas, incluyendo plomo y otros metales pesados, los cuales son conocidos por el Estado de California como causantes de daños congénitos y defectos reproductivos. Para más información, visite www.P65Warnings.ca.gov



Carrier

5

SCOPE OF WORK REQUIRED – CITY OF LEWISVILLE

Address: _____

System Repair Partial Install Full System replacement

Summary of requirements to restore to operation & bring to code Recommendation is

to replace the full HVAC system. Install a New C-Cabinet Furnace 80,000BTU 4-ton Drive, Evaporator Coil, Filter Base & outside Condenser, Condenser pad 4-ton unit.

Overview of diagnostic findings HVAC is over 20 years, the outside condensing unit does not work. A.C. system is not efficient to Heat or Cool Home.

Current equipment – Model & Serial

MFG.	Model #	Serial #
Outdoor TRANE	TTR048D100A2	
Air handler/Furn International Comfort Product	FBF075F16G1	
Evaporator	ICP EPA48F19C1	
Thermostat	Digital Type - Honeywell	

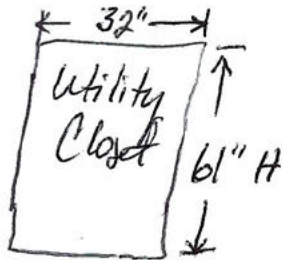

Detail of requirements

Recommendation are to install a new 4-ton Furnace and Evaporator coil, Filter Base in Utility Closet, Replace the outside 4-ton Condenser & Pad.

- ① 4-ton Drive Furnace
- ② 4-ton Evaporator Coil
- ③ Filter Base in Utility Closet
- ④ outside 4-ton Condenser & Pad

INTERNATIONAL COMFORT PRODUCTS
CORPORATION (USA)
LEWISBURG, TN USA 37091
EVAPORATOR COIL
MODEL NO. EPA48F19A1

CASED MODEL NO.
MODEL NO. EPM48F19C1

MFG. NO. EPM48F19C1
SERIAL NO. L0225 77406
INSTALLED RESTRICTOR 079
DESIGN PRESSURE 300 PSIG
REFRIGERANT 22

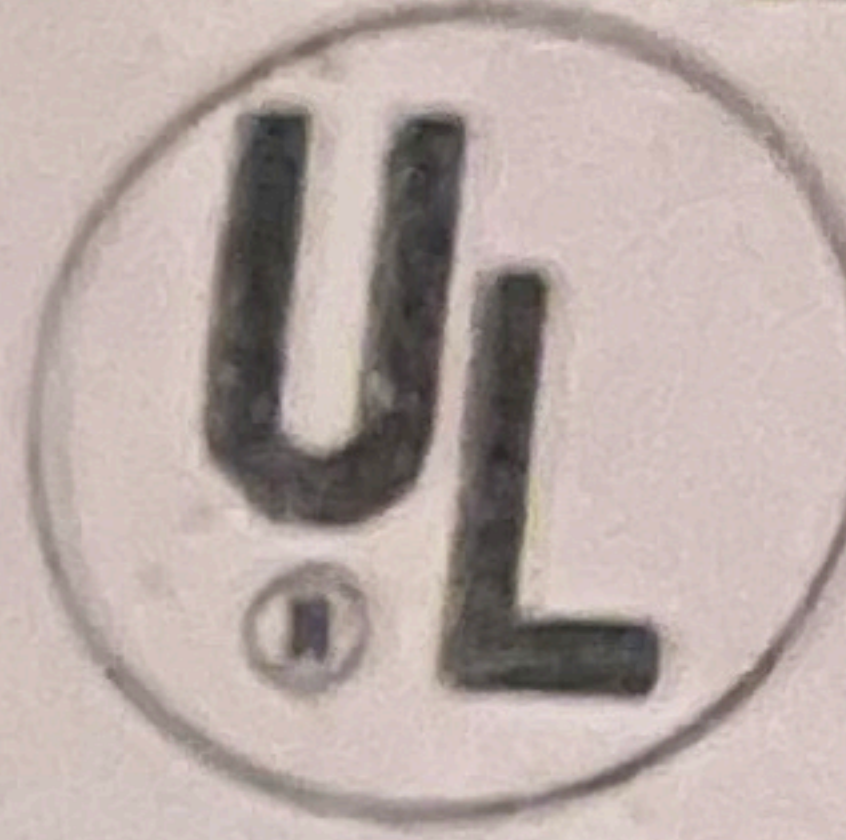

LISTED 13XF
REFRIGERANT
EVAPORATOR ALSO
AS SECTION OF
HEAT PUMP

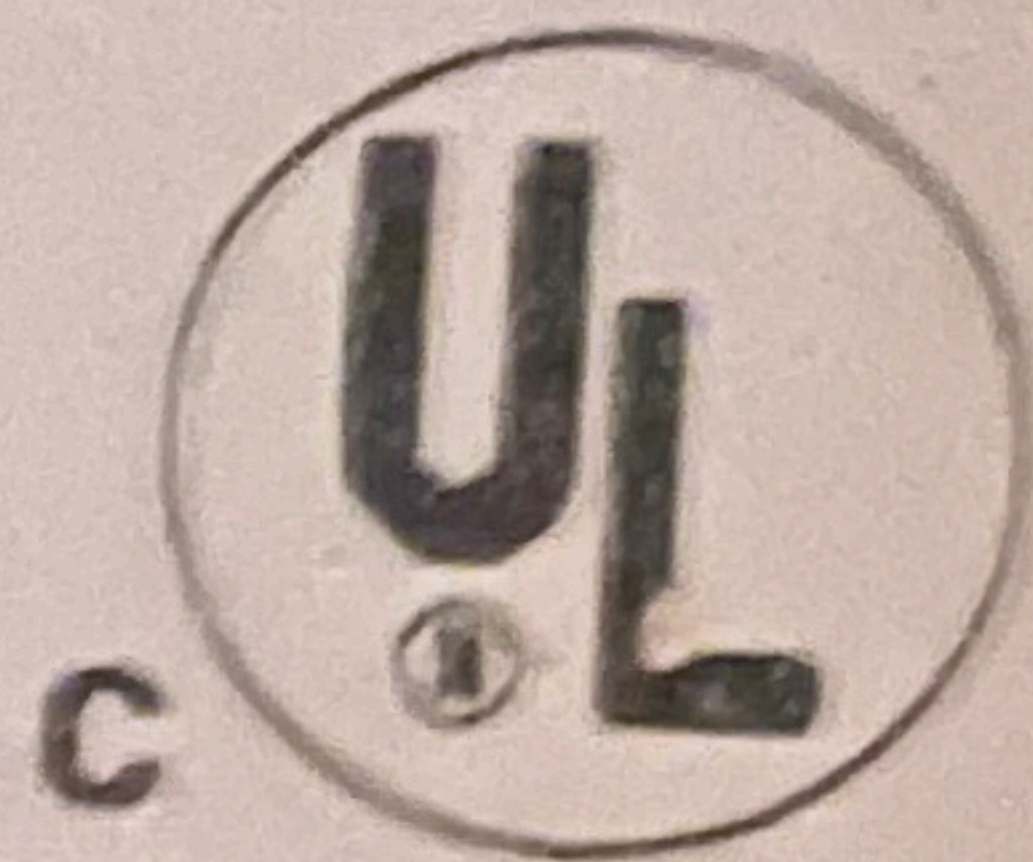

UNION MADE, LOCAL 8-14
DIVISION OF BOILERMAKERS INTERNATIONAL

INTERNATIONAL COMFORT PRODUCTS CORPORATION (USA)
LEWISBURG, TN USA 37091



SERIAL NO. L0223 61352
ANS Z21.47a*CSA - 2.3a 1999 CENTRAL FURN.

MODEL NO. FBF075F16G1
MFG. NO. NTG3075HFG1
MODEL NO. NTG3075HFG1

INDOOR FORCED AIR FURNACE FOR BUILDING CONSTRUCTED ON SITE
GÉNÉRATEUR D'AIR CHAUD ENCASTRÉ POUR BÂTIMENT

EQUIPPED FOR NATURAL GAS
L.P. GAS CONVERTIBLE WITH
CERTIFIED FACTORY KIT
CATEGORY 1

VOLTS AC 115 /PH 1/ HZ 60
MAX. INPUT AMPS 12.0

INPUT 75,000 BTU/HR

MAX. GAS SUPPLY PRESS. 14.0 IN W.C.
MIN. GAS SUPPLY PRESS. FOR
INPUT ADJ. 4.5 IN W.C.

MANIFOLD PRESSURE 3.5 IN W.C.
TEMPERATURE RISE 25 - 55 DEG. F
MAX. STATIC PRESS. 0.5 IN W.C.
DESIGN MAX. AIR TEMP 175 DEG. F

FOR INDOOR INSTALLATION

FOR INSTALLATION ON COMBUSTIBLE FLOORING IN ALCOVE OR CLOSET AT MINIMUM CLEARANCE FROM
COMBUSTIBLE MATERIAL AS SHOWN BELOW.
PEUT ÊTRE INSTALLÉE SUR UN PLANCHER COMBUSTIBLE DANS UN PLACARD OU UNE ALCOVE, A UNE
DISTANCE MINIMUM DU MATÉRIAU COMBUSTIBLE COMME INDIQUE.

TOP DESSUS	SIDES COTÉS	BACK ARRIÈRE	FRONT AVANT	VENT ÉVENT	INCHES (POUCES)
1	0	0	6	6	WITH SINGLE WALL VENT AVEC UTILISATION D'UN ÉVENT À PAROI UNIQUE.
1	0	0	3	1	WITH TYPE B-1, AVEC UTILISATION D'UN ÉVENT TYPE B-1.

SEE INSTRUCTIONS FOR ALTITUDE OPERATION ABOVE 2000 FT.
POUR FONCTIONNEMENT A UNE ALTITUDE PLUS HAUTE QUE 2.000 PIEDS. ET POUR LES CONVERSIONS
D'ALIMENTATION ALTERNÉES. RÉFÉREZ VOUS AUX INSTRUCTIONS.

UNION MADE, LOCAL S-14 DIVISION OF BOILERMAKERS INTERNATIONAL

XE 1000

MOD. NO. TTR048D100A2 MFR DATE 07/2001
SERIAL NO. Z275YMK3F
MINIMUM CIRCUIT AMPACITY VOLTS 208/230
OVERCURRENT PROTECTIVE DEVICE PH 1 HZ 60
MIN FUSE / BREAKER (HACR) 31/29 AMP'S
MAX FUSE / BREAKER (HACR) USA 40 CANADA 40
HCFC - 22 5 LBS. 06 OZ. OR 50 50
BAYFCCV 083A REQUIRED INDOORS FOR RATED PERFORMANCE 2.44 Kg(lb)
THE TRANE COMPANY ASSEMBLED IN USA c UL OUTDOOR USE
TYLER, TX 75711-9010
COMPR. MOT. 23/22LA
O.D. MOT. 1.50 FLA
M.E.A. NO. 56-92E 208/230 V 131 LRA
DESIGN PSI - HIGH 300 LOW 300 200/230 V 1/5 HP
F. ID. R49



PRODU...
REFER TO...
WITH THIS...
OPERATION...
Disturbing the...
installation, main...
airborne particles...
known to the State...
inhalation. Glasswool...
skin or eye irritation.



XE 1000

MFR
DATE 07/2001

MOD. NO.	TTR048D100A2	VOLTS	208/230
SERIAL NO.	Z275YMK3F	PH 1	HZ 60
MINIMUM CIRCUIT AMPACITY		31/29	AMPS
OVERCURRENT PROTECTIVE DEVICE		USA	CANADA
MIN FUSE / BREAKER (HACR)		40	40
MAX FUSE / BREAKER (HACR)		50	50
HCFC - 22	5 LBS. 06 OZ.	OR	2.44 Kg(alt)
BAYFCCV	083A	REQUIRED INDOORS FOR RATED PERFORMANCE	

THE TRANE COMPANY
TYLER, TX 75711-9010 ASSEMBLED IN USA  OUTDOOR USE

COMPR. MOT.	23/22LA	208/230 V	131 LRA
O.D. MOT.	1.50 FLA	200/230 V	1/5 HP
M.E.A. NO.	56 - 92E	F. ID. R49	
DESIGN PSI - HIGH 300 LOW 300			

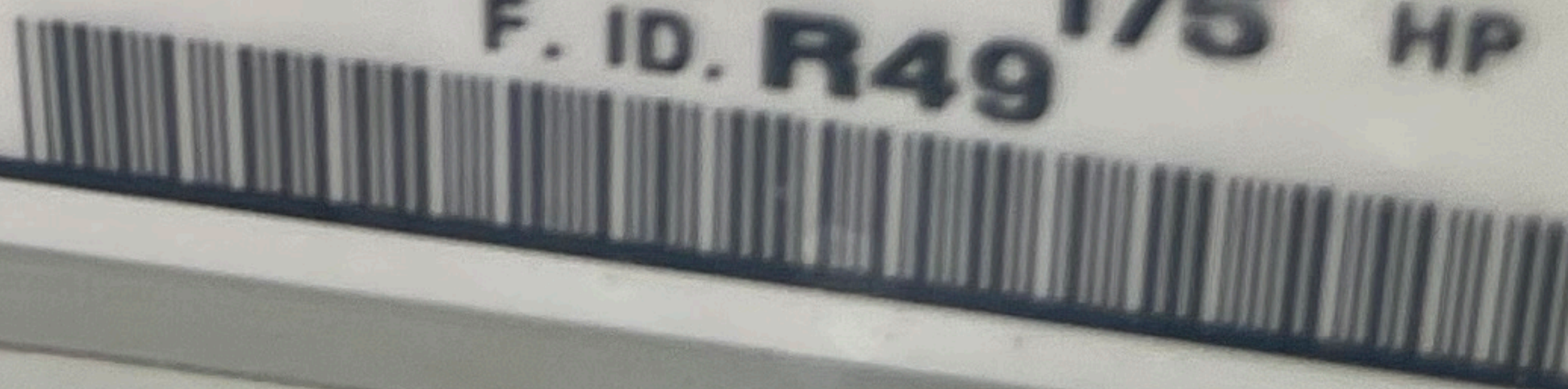



TRANE

HIGH EFFICIENCY
AIR CONDITIONER **XE 1000**

AIR FILTER

#2

SCOPE OF WORK REQUIRED – CITY OF LEWISVILLE

Address: [REDACTED]

System Repair

Partial Install

Full System replacement

Summary of requirements to restore to operation & bring to code

Recommendation is

to replace the whole HVAC system, it's over 16yrs. Old. The A.C. system is not efficient any more.

Overview of diagnostic findings

HVAC System over 16 years old, recommendation

is to replace the full system due to age & inefficiency.

Current equipment – Model & Serial

	Model #	Serial #
Outdoor American std.	4A7B4036E1000AA	[REDACTED]
Air handler <u>FURN</u>	AUD080R9V4K5	[REDACTED]
Evaporator American std.	4TXFHD63A531HAB	[REDACTED]
Thermostat	Honeywell - T-Stat	[REDACTED]

Detail of requirements

Garage Access to Furnace & Evaporator Coil in Attic.

Attic opening 23" X 48" Standard pull down Door.

- ① 80,000 BTU Furnace C-Cabinet 3-ton Drive
- ② Evaporator Coil C-Cabinet, Aux Drain Pan
- ③ Supply Air Plenum - will need flex Ductwork to tie into Hard Ductwork.
- ④ 3-ton outside Condenser
- ⑤ Condenser Pad for outside Unit.
- ⑥ Digital Thermostat

Trane
Tyler, TX 75707

ASSEMBLED IN USA

MODEL NO. 4TXFH063AS3HHAB SERIAL NO. 9352JOB7H

FTS

REFRIGERANT R410A

MFG DATE 8/2009

DESIGN PSI 480



SECTION OF
CENTRAL COOLING
AIR CONDITIONER
US 3059934

ALSO
LISTED
SECTION OF
HEAT PUMP

D932303P01



WARNING

CONTAINS REFRIGERANT!

SYSTEM CONTAINS OIL AND REFRIGERANT UNDER HIGH PRESSURE. RECOVER REFRIGERANT TO RELIEVE PRESSURE BEFORE OPENING THE SYSTEM. SEE OUTDOOR UNIT NAMEPLATE FOR REFRIGERANT TYPE. DO NOT USE NON-APPROVED REFRIGERANTS OR REFRIGERANT SUBSTITUTES OR REFRIGERANT ADDITIVES.

Failure to follow proper procedures or the use of non-approved refrigerants or refrigerant substitutes or refrigerant additives could result in death or serious injury or equipment damage.

WARNING

PRODUCT CONTAINS FIBERGLASS WOOL!

REFER TO OWNER'S INFORMATION MANUAL PROVIDED WITH THIS UNIT FOR PROPER INSTALLATION, OPERATING AND MAINTENANCE INSTRUCTIONS.

Disturbing the insulation in this product during installation, maintenance or repair will expose you to airborne particles of glass wool fibers and ceramic fibers known to the state of California to cause cancer through inhalation. Glass wool fibers could also cause respiratory, skin or eye irritation.

AVERTISSEMENT

CE PRODUIT CONTIENT UN FLUIDE FRIGORIGÈNE!

LE SYSTÈME CONTIENT DE L'HUILE ET UN FLUIDE FRIGORIGÈNE SOUS HAUTE PRESSION. RÉCUPÉRER LE FLUIDE FRIGORIGÈNE POUR FAIRE CHUTER LA PRESSION AVANT D'OUVRIR LE SYSTÈME. CONSULTER LA PLAQUE SIGNALÉTIQUE À L'EXTÉRIEUR DE L'UNITÉ POUR CONNAÎTRE LE TYPE DE FLUIDE FRIGORIGÈNE UTILISÉ. NE PAS UTILISER DE FLUIDES FRIGORIGÈNES NON AUTORISÉS, DE FLUIDES FRIGORIGÈNES DE SUBSTITUTION NI D'ADDITIFS DE FLUIDES FRIGORIGÈNES.

Si la procédure appropriée n'est pas suivie ou si des fluides frigorigènes non autorisés, des fluides frigorigènes de substitution ou des additifs de fluides frigorigènes sont utilisés, la mort, des blessures graves ou l'endommagement du matériel pourraient s'ensuivre.

AVERTISSEMENT

CE PRODUIT CONTIENT DE LA LAINE DE VERRE!

CONSULTER LE GUIDE D'UTILISATION DU PROPRIÉTAIRE REMIS AVEC CETTE UNITÉ POUR CONNAÎTRE LES DIRECTIVES D'INSTALLATION, DE FONCTIONNEMENT ET D'ENTRETIEN.

Des particules de fibres de laine de verre et de céramique, reconnues par l'État de Californie comme pouvant provoquer des cancers par inhalation, peuvent être projetées pendant l'isolation ou de produit en cours d'installation, d'entretien ou de réparation. Les fibres de laine de verre pourraient aussi causer des problèmes respiratoires, des irritations de la peau et des yeux.

X39002511010B

AUD080R9V4K5

938639L1G

11

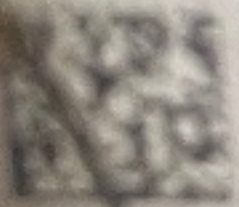

Carrier U.S. Inc.
Manufacturer of American Standard
Heating and Air Conditioning
Equipment, N.Y. 08619. Assembled in USA

MODEL NO: AUD080R9V4K5
SERIAL NO: 938639L1G
DATE OF MANUFACTURE: 9/2009
NUMERO DE MODELE:
NUMERO DE SERIE:

CATEGORY I FORCED AIR FURNACE FOR INDOOR INSTALLATION ONLY IN A BUILDING
CONSTRUCTED ON SITE.

ELECTRICAL: 115 V, 60 HZ, 1 PH.; MINIMUM SUPPLY CIRCUIT CONDUCTOR AMPACITY 13.0 AMPS,
MAXIMUM OVERCURRENT PROTECTION DEVICE 20 AMPS
FACTORY EQUIPPED WITH NO. 45 DRILL SIZE ORIFICE FOR NATURAL GAS
FACTORY INPUT 80,000 BTU/HR (23.45 KW) AT 3.5" W.C (0.87 KPA) MANIFOLD PRESSURE
FACTORY INPUT 52,000 BTU/HR (15.24 KW)

MAXIMUM PERMISSIBLE GAS SUPPLY PRESSURE TO FURNACE 13.8" W.C. (3.43 KPA) FOR BOTH
NATURAL GAS AND PROPANE
MINIMUM GAS SUPPLY PRESSURE FOR PURPOSES OF INPUT ADJUSTMENT 5.0" W.C. (1.24 KPA) FOR
NATURAL GAS OR 11.0" W.C. (2.49 KPA) FOR PROPANE

MAXIMUM EXTERNAL STATIC PRESSURE (HEATING) 0.50" W.C. (.125 KPA)
RISE RANGE 30 °F TO 60 °F (17 °C TO 33 °C)
DESIGN MAXIMUM OUTLET AIR TEMPERATURE 160 °F (71 °C) LIMIT SETTING 160 °F (71 °C)

MAXIMUM ABOVE 2000 FT. DERATE THE TOTAL & MINIMUM INPUT 4 % PER 1000 FT ABOVE SEA LEVEL.
CATEGORY I GENERATEUR D'AIR CHAUD A AIR FORCE POUR INSTALLATION A L'INTERIEUR
SEULEMENT.

ELECTRIQUE 115 V, 60 HZ, 1 PH.; PUISSANCE D'ENTREE TOTALE MAXIMUM 13.0 A.
MAXIMUM CAPACITE 20 A
A L'USINE POUR NATUREL GAZ, L'ORIFICE EST IDENTIQUE AU TROU D'UN FORÉT N° 45
CALORIFIQUE 80,000 BTU/HR (23.45 KW) A 3.5 PO C.E. (0.87 KPA) PRESSION A LA TUBULURE



Model: 75077
Type: TR
REFRIGERANT: R410A
Capacity: 480
SECTION BY: CENTRAL COASTLINE AIR CONDITIONERS & HEATING
ALSO LISTED SECTION BY: HEAT PUMP

▲ WARNING
CONTAINS REFRIGERANT!
DO NOT OPEN OR REMOVE REFRIGERANT FROM THIS UNIT. REFRIGERANT IS UNDER HIGH PRESSURE. REFRIGERANT RELEASED FROM THIS UNIT CAN BE DANGEROUS TO YOUR HEALTH. IF REFRIGERANT IS RELEASED, CONTACT YOUR LOCAL FIRE DEPARTMENT FOR ASSISTANCE. DO NOT ATTEMPT TO REPAIR OR RECHARGE THIS UNIT. ONLY A LICENSED REFRIGERATION TECHNICIAN SHOULD ATTEMPT TO REPAIR OR RECHARGE THIS UNIT.

▲ AVERTISSEMENT
CE PRODUIT CONTIENT UN FLUIDE FRIGORIGÈNE!
NE PAS OUVRIRE NI ENLEVER LE FLUIDE FRIGORIGÈNE DE CETTE UNITÉ. LE FLUIDE FRIGORIGÈNE EST SOUS HAUTE PRESSE. LE FLUIDE FRIGORIGÈNE LIBÉRÉ DE CETTE UNITÉ PEUT ÊTRE DANGEREUX POUR VOTRE SANTÉ. SI LE FLUIDE FRIGORIGÈNE EST LIBÉRÉ, CONTACTEZ VOTRE DÉPARTEMENT LOCAL DES SAUVEVIEUX POUR OBTENIR DE L'ASSISTANCE. NE PAS TENTER DE RÉPARER NI DE RECHARGER CETTE UNITÉ. SEUL UN TECHNICIEN QUALIFIÉ EN RÉFRIGÉRATION PEUT RÉPARER OU RECHARGER CETTE UNITÉ.

▲ WARNING
PRODUCT CONTAINS FIBERGLASS WOOL!
DO NOT REMOVE INSULATION FROM THIS UNIT. REMOVAL OF INSULATION CAN BE DANGEROUS TO YOUR HEALTH. IF INSULATION IS REMOVED, CONTACT YOUR LOCAL FIRE DEPARTMENT FOR ASSISTANCE. DO NOT ATTEMPT TO REPAIR OR RECHARGE THIS UNIT. ONLY A LICENSED REFRIGERATION TECHNICIAN SHOULD ATTEMPT TO REPAIR OR RECHARGE THIS UNIT.

▲ AVERTISSEMENT
CE PRODUIT CONTIENT DE LA LAINE DE VERRE!
NE PAS ENLEVER L'ISOLATION DE CETTE UNITÉ. L'ENLEVEMENT DE L'ISOLATION PEUT ÊTRE DANGEREUX POUR VOTRE SANTÉ. SI L'ISOLATION EST ENLEVÉE, CONTACTEZ VOTRE DÉPARTEMENT LOCAL DES SAUVEVIEUX POUR OBTENIR DE L'ASSISTANCE. NE PAS TENTER DE RÉPARER NI DE RECHARGER CETTE UNITÉ. SEUL UN TECHNICIEN QUALIFIÉ EN RÉFRIGÉRATION PEUT RÉPARER OU RECHARGER CETTE UNITÉ.

American Standard

MFR DATE 7/2009

MOD. NO. 4A7B4036E1000AA VOLTS 208/230
SERIAL NO. 92851NS5F PH 1 HZ 60
MINIMUM CIRCUIT AMPACITY 19.0 AMPS
OVERCURRENT PROTECTIVE DEVICE USA CANADA
MIN FUSE / BREAKER (HACR) 30 30
MAX FUSE / BREAKER (HACR) 30 30
HFC - 410A 7 LBS. 04 OZ. OR 3.28 kg(SI)
11 °F DESIGN SUBCOOLING

TRANE U.S. INC.
MANUFACTURER OF TRANE AND AMERICAN STANDARD
TYLER, TX 75707

ASSEMBLED IN USA  LISTED SECTION OF
CENTRAL COOLING
AIR CONDITIONER
23MF OUTDOOR USE
COMPR. MOT. 14.1 RLA 208/230 V 77 LRA
O.D. MOT. 1.10 FLA 200/230 V 1/5 HP
M.E.A. NO. DESIGN PSI - HIGH 480 LOW 480 F. ID. BGP



ARI Standard
210/240 UAC
CERTIFICATION APPLIES ONLY
WHEN THE COMPLETE SYSTEM
IS LISTED WITH ARI

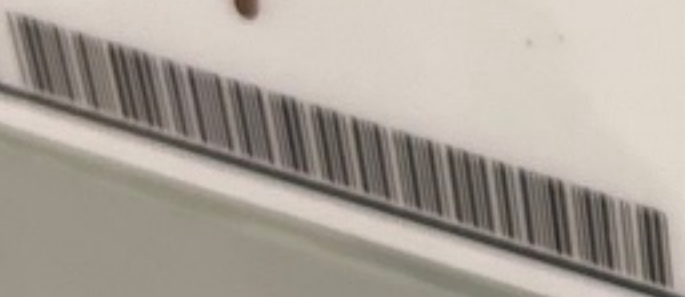



TRIS









American Standard

CITY OF LEWISVILLE

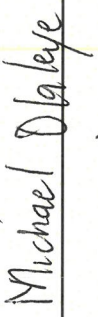
PRE-BID

RFB #26-74-B Pre-Bid Meeting

2:00 P.M., Monday, April 20, 2026

	NAME (PRINT)	COMPANY	PHONE NUMBER	EMAIL ADDRESS
1	Janine Carpenter 	City of Lewisville	972-219-3766	jcarpenter@cityoflewisville.com
2	Elena Shehan 	City of Lewisville	972-219-3780	eshehan@cityoflewisville.com
3	Stacy S Ston 	K/Stone/AC GEEKS	972-224-0805	DEMETRA@ELSTONAIRE.COM STACY@ELSTONAIRE.COM
4	Michael Dajeye 	Chrome Mechanical	972-898-3892	michael@chromeairconditioning.com
5	Tyrone Noms 	Norris Heat & Air	(214) 254-6781	service@norrisheatandair.com
6	Alex Peebles 	Ridgewood Solutions	(469) 668-5158	alex@ridgewoodsolutions.com
7	David Manley 	Infinity Commercial ^{Home Cont}	210-710-3904	David.Manley@gmail.com
8	Richard Sprenger 	Custom Heating & Air Conditioning	817-584-5403	rsprenger@customheating-ac.com
9	Richard Elliott 	Elliott Refrigeration & HVAC	817-807-1581	elliottrefrigeration@gmail.com
10	Stanee Leper-Elliott 	Elliott Refrigeration & HVAC	817-807-1581	elliottrefrigeration@gmail.com
11				
12				
13				
14				
15				