

LEWISVILLE CITY COUNCIL

REGULAR SESSION

FEBRUARY 3, 2020

Present:

Rudy Durham, Mayor

Council Members:

TJ Gilmore
Bob Troyer, Mayor Pro Tem
R Neil Ferguson, Deputy Mayor Pro Tem
Kristin Green
Brandon Jones

City Staff:

Donna Barron, City Manager
Eric Ferris, Deputy City Manager
Claire Powell, Assistant City Manager
Melinda Galler, Assistant City Manager
Julie Worster, City Secretary
Lizbeth Plaster, City Attorney

WORKSHOP SESSION – 5:45 P.M.

With a quorum of the Council Members present, the workshop session of the Lewisville City Council was called to order by Mayor Durham at 5:45 p.m. on Monday, February 3, 2020, in the City Council Conference Room of the Lewisville City Hall, 151 West Church Street, Lewisville, Texas. All City Department Heads were in attendance.

**Discussion of Regular Agenda Items and
Consent Agenda Items**

(Agenda Item A)

Mayor Durham reviewed Agenda Item A, Invocation. There was no discussion on this item.

Mayor Durham reviewed Agenda Item B, Pledge to the American and Texas Flags. There was no discussion on this item.

Mayor Durham reviewed Agenda Item C, Presentation: Presentation of the 2020 ColorPalooza Logo and 2020 ColorPalooza Logo Student Contest Winner. There was no discussion on this item.

WORKSHOP SESSION – 5:45 P.M.

**Discussion of Regular Agenda Items and
Consent Agenda Items (cont'd)**

(Agenda Item A)

Mayor Durham reviewed Agenda Item D-1, Public Hearing: Consideration of an Ordinance Grating a Zone Change Request from General Business District (GB) to Old Town Mixed Use 2 District (OTMU2); on Approximately 0.667 Acres, Legally Described as a Tract of Land Out of the J.W. King Survey, Abstract No. 696 and Located on the Southeast Quadrant of Elm Street and South Charles Street at 187 and 189 Elm Street; as Requested by Patricia Fant of G&A | McAdams, on Behalf of Mike Johnson, the Property Owner. (Case No. 19-11-2-PZ) There was no discussion on this item.

Mayor Durham reviewed Agenda Item E, Visitors/Citizens Forum. There was no discussion on this item.

Mayor Durham reviewed Agenda Item F-2, Approval of City Council Minutes of the January 27, 2020, Workshop Session and Regular Session. There was no discussion on this item.

Mayor Durham reviewed Agenda Item F-3, Approval of an Economic Development Agreement Between the City of Lewisville and TurboChef Technologies, Inc. and Authorization for the City Manager to Execute the Agreement. There was no discussion on this item.

Mayor Durham reviewed Agenda Item F-4, Approval of Additional Services Proposal for Architectural Services with Barker Rinker Seacat Architecture to Provide Services Beyond the Original 18 Month Construction Scope; in the Amount of \$81,344; and Authorization for the City Manager to Execute the Proposal. There was no discussion on this item.

Mayor Durham reviewed Agenda Item F-5, Approval of a Resolution Authorizing the Filing of a Project Application with the North Central Texas Council of Governments (NCTCOG) for a Regional Solid Waste Program Local Project; Approval of a Supplemental Appropriation to the Grant Fund in the Amount of \$22,950; and Authorization for the City Manager or Her Designee to Act on Behalf of the City of Lewisville in all Matters Related to the Application. There was no discussion on this item.

Mayor Durham reviewed Agenda Item G-6, Consideration of a Variance to the Lewisville City Code Section 2-201, Fee Schedule, Regarding Waiving Rental Fees at the Hedrick House, as Requested by Nicole Franczvai and her group Lewisville SOUP. There was no discussion on this item.

Mayor Durham reviewed Agenda Item H, Reports. There was no discussion on this item.

Mayor Durham reviewed Agenda Item J-Closed Session. There was no discussion on this item.

WORKSHOP SESSION – 5:45 P.M.

Upper Trinity Update

(Agenda Item B)

Larry Patterson, P.E. Upper Trinity Regional Water Executive Director, reviewed the attached PowerPoint Presentation for City Council consideration. Board President Rich Lubke addressed the City Council and acknowledged the contributions that Deputy City Manager Eric Ferris brings to the Board of Directors.

Briefing on Building and Fire Code Amendments

(Agenda Item C)

Lewisville Building Official Jeremy Booker along with Fire Marshall/Development Manager Tim Ippolito presented the attached PowerPoint Presentation for City Council consideration.

Discussion was held regarding required change for remodels to have the residential electrical service disconnect located on the outside of the house. At the questioning of Councilmember Gilmore, City staff advised that it was \$200 for the parts, not the labor costs, to make the change to add a breaker box on the outside of the house. Councilmember Green inquired if there was some type of security on the box to prevent tampering. City staff indicated that the homeowner could put a lock on the box and that if needed, the Fire Department could cut the lock. Assistant Fire Chief Mark McNeal advised that this change would make a big difference for the safety of the crews.

Assistant Fire Chief Terry McGrath showed portions of a video which detailed the volatility of a fire located in an apartment complex parking garage ((<https://www.youtube.com/watch?v=yNznPAY5zk&feature=youtu.be>)).

With no further discussion, the workshop session of the Lewisville City Council was adjourned at 6:36 p.m. on Monday, February 3, 2020.

REGULAR SESSION – 7:00 P.M.

With a quorum of the Council Members present, the regular session of the Lewisville City Council was called to order by Mayor Durham at 7:00 p.m. on Monday, February 3, 2020, in the Council Chambers of the Lewisville City Hall, 151 West Church Street, Lewisville, Texas.

Invocation

(Agenda Item A)

At the request of Mayor Durham, Mayor Pro Tem Troyer gave the invocation.

Pledge to the American and Texas Flags

(Agenda Item B)

Mayor Durham gave the pledge to the American and Texas flags.

**Presentation: Presentation of the 2020
ColorPalooza Logo and 2020 ColorPalooza
Logo Student Contest Winner**

(Agenda Item C)

Art Center Manager Denise Helbing presented 2020 ColorPalooza Logo and winner of the 2020 ColorPalooza student logo contest, to Landy Martinez, Lewisville High School Senior.

**Public Hearing: Consideration of Ordinance
No. 0193-20-ZON Grating a Zone Change
Request from General Business District (GB)
to Old Town Mixed Use 2 District (OTMU2);
on Approximately 0.667 Acres, Legally
Described as a Tract of Land Out of the J.W.
King Survey, Abstract No. 696 and Located
on the Southeast Quadrant of Elm Street and
South Charles Street at 187 and 189 Elm
Street; as Requested by Patricia Fant of
G&A | McAdams, on Behalf of Mike
Johnson, the Property Owner. (Case No.
19-11-2-PZ)**

(Agenda Item D-1)

The applicant, Mike Johnson, owns a feed store in Lewisville but plans to move his business to Old Town. He is proposing to rezone the property to Old Town Mixed Use 2. The Planning and Zoning Commission recommended unanimous approval (7-0) of the zone change request on January 7, 2020.

The City staff's recommendation was that the City Council approve the ordinance as set forth in the caption above.

Mayor Durham opened the public hearing.

Richard E. Luedke, Planning Director; Mike Johnson, 901 N. Mill Street, Lewisville, Texas; and Patricia Fant, 111 Hillside Drive, Lewisville, Texas, were all present to address any questions posed by the City Council.

MOTION: Upon a motion made by Mayor Pro Tem Troyer and seconded by Deputy Mayor Pro Tem Ferguson, the Council voted five (5) "ayes" and no (0) "nays" to close the public hearing. The motion carried.

Public Hearing: Consideration of Ordinance No. 0193-20-ZON Grating a Zone Change Request from General Business District (GB) to Old Town Mixed Use 2 District (OTMU2); on Approximately 0.667 Acres, Legally Described as a Tract of Land Out of the J.W. King Survey, Abstract No. 696 and Located on the Southeast Quadrant of Elm Street and South Charles Street at 187 and 189 Elm Street; as Requested by Patricia Fant of G&A | McAdams, on Behalf of Mike Johnson, the Property Owner. (Case No. 19-11-2-PZ) (cont'd)

(Agenda Item D-1)

City Attorney Lizbeth Plaster read the ordinance caption into the record as follows:

“An Ordinance of the Lewisville City Council, Amending the Zoning Ordinance by Rezoning Approximately 0.667-Acres, Legally Described as a Tract of Land out of the J.W. King Survey, Abstract No. 696 and Located on the Southeast Quadrant of Elm Street and South Charles Street at 187 and 189 Elm Street, From General Business (GB) District Zoning to Old Town Mixed Use 2 (OTMU2) District Zoning; Correcting the Official Zoning Map; Preserving all Other Portions of the Zoning Ordinance; Determining That the Public Interests and General Welfare Demand This Zoning Change and Amendment Therein Made; Providing for a Repealer, Severability, a Penalty, and an Effective Date; and Declaring an Emergency.”

MOTION: Upon a motion made by Councilmember Jones and seconded by Councilmember Green, the Council voted five (5) “ayes” and no (0) “nays” to approve and adopt **Ordinance No. 0193-20-ZON**, as previously captioned. The motion carried.

Visitors/Citizens Forum

(Agenda Item E)

Robert Jander, 1326 Falcon Drive, Lewisville, Texas, spoke before the City Council to expressed thanks to the City Council for their support of the Lewisville Fire Department.

No one else appeared to speak at this time.

CONSENT AGENDA

(Agenda Item F)

MOTION: Upon a motion made by Councilmember Gilmore and seconded by Councilmember Green, the Council voted five (5) “ayes” and no (0) “nays” to approve and adopt all items on the Consent Agenda, as recommended and as follows:

2. APPROVAL OF MINUTES: City Council Minutes of the January 27, 2020, Workshop Session and Regular Session.
3. Approval of an Economic Development Agreement Between the City of Lewisville and TurboChef Technologies, Inc. and Authorization for the City Manager to Execute the Agreement.
4. Approval of Additional Services Proposal for Architectural Services with Barker Rinker Seacat Architecture to Provide Services Beyond the Original 18 Month Construction Scope; in the Amount of \$81,344; and Authorization for the City Manager to Execute the Proposal.
5. Approval of Resolution No. 0194-20-RES Authorizing the Filing of a Project Application with the North Central Texas Council of Governments (NCTCOG) for a Regional Solid Waste Program Local Project; Approval of a Supplemental Appropriation to the Grant Fund in the Amount of \$22,950; and Authorization for the City Manager or Her Designee to Act on Behalf of the City of Lewisville in all Matters Related to the Application.

The motion carried.

END OF CONSENT AGENDA

**Consideration of a Variance to the Lewisville
City Code Section 2-201, Fee Schedule,
Regarding Waiving Rental Fees at the
Hedrick House, as Requested by Nicole
Franczvai and her group Lewisville SOUP**

(Agenda Item G-6)

Nicole Franczvai and Lewisville SOUP are requesting a fee waiver related to use of the Hedrick House for four separate potluck events during 2020 and 2021. Lewisville SOUP is a crowd-funded, microgrant program that is run exclusively by volunteers from our community. It is based on the nationally-known and celebrated Detroit SOUP program. Attendees bring soup, salad, or bread for a potluck meal. They also bring a \$10 donation that will allow them to vote on a project they want to fund. Attendees then enjoy a meal and hear from up to four presenters that hope to get their project funded. Projects will range from art, urban agriculture, social justice, social entrepreneurs, education, technology and more. But all presentations would be focused on ways to make Lewisville a more creative, loveable, and engaging place.

The City staff's recommendation was that the City Council approve the requested waiver of rental fees as set forth in the caption above.

Claire Powell, Assistant City Manager, was present to address any questions posed by the City Council.

Jennifer Linde, 1518 Springaire Lane, Lewisville, Texas, spoke before the City Council in support of the variance request.

City Secretary Julie Worster advised the following individuals had filled out cards indicating their support of this item.:

Nicole Franczvai, 1301 Forestglen Drive, Lewisville, Texas
Steve and Jennifer Southwell, 995 Downey Drive, Lewisville, Texas
DeAnna Perkins, 1360 Daffodil Lane, Lewisville, Texas

MOTION: Upon a motion made by Deputy Mayor Pro Tem Ferguson and seconded by Councilmember Jones, the Council voted five (5) "ayes" and no (0) "nays" to approve a variance to the Lewisville City Code Section 2-201, Fee Schedule, Regarding Waiving Rental Fees at the Hedrick House, as requested by Nicole Franczvai and her group Lewisville SOUP. The motion carried.

Reports

(Agenda Item H)

- Deputy Mayor Pro Tem Ferguson reviewed upcoming events at the MCL Grand.
- Mayor Pro Tem Troyer reviewed the success of Lewisville's first professional basketball team event held over the weekend.
- Mayor Durham thanked the Police Officers present for their service to the community.

There were no additional reports at this time.

Return to Workshop Session if Necessary

(Agenda Item I)

Due to completing all workshop session items, there was no need for the City Council to return to the City Council Conference Room to complete any workshop items.

Mayor Durham adjourned the regular session of the Lewisville City Council into Closed Session at 7:16 p.m. Monday, February 3, 2020, in accordance with the requirements of the Open Meetings Law.

Closed Session

(Agenda Item J)

In accordance with Texas Government Code, Subchapter D, Section 551.072 (Real Estate), the Lewisville City Council convened into Closed Session at 7:23 p.m. on Monday, February 3, 2020, City Council Conference Room of the Lewisville City Hall, 151 West Church Street, Lewisville, Texas, in order to discuss matters pertaining to the following:

1. Property Acquisition

Section 551.087 (Economic Development):

2. Deliberation Regarding Economic Development Negotiations.

The Closed Session was adjourned at 7:48 p.m. on Monday, February 3, 2020.

Reconvene into Regular Session and Consider Action, if any, on Items Discussed in Closed Session

(Agenda Item K)

Mayor Durham reconvened the Regular Session of the Lewisville City Council at 7:48 p.m. on Monday, February 3, 2020, in the Council Chambers of the Lewisville City Hall.

Mayor Durham opened the floor for action to be taken on the items discussed in the Closed Session. There was no action taken on the items discussed during the Closed Session.

Adjournment

(Agenda Item L)

MOTION: Upon a motion made by Councilmember Jones and seconded by Deputy Mayor Pro Tem Ferguson, the Council voted five (5) “ayes” and no (0) “nays” to adjourn the Regular Session of the Lewisville City Council at 7:48 p.m. on Monday, February 3, 2020. The motion carried.

These minutes approved by the Lewisville City Council on the 17th day of February, 2020.

APPROVED

Rudy Durham
MAYOR

ATTEST:

Julie Worster
CITY SECRETARY

DRAFT MINUTES

Water for the People...It Takes Leadership

City of Lewisville Council Workshop Session February 3, 2020

Larry N. Patterson, P.E.
Executive Director

UPPER TRINITY

REGIONAL WATER DISTRICT
1908 KEELY

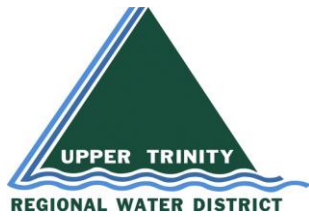

UTRWD - - History

*Began with no facilities or money - - just a **VISION** - - to develop a regional network of water & wastewater treatment facilities to **SERVE THE PEOPLE***

- **Created by Texas Legislature in 1989**
- **Wholesale Water & Wastewater Service Provider**
- **First water service provided in 1997**
- **Promotes protection of watersheds and greenbelt areas**
- **Responsible Agency for Long Range Water Supply Planning (Denton County)**

Denton County Population Growth

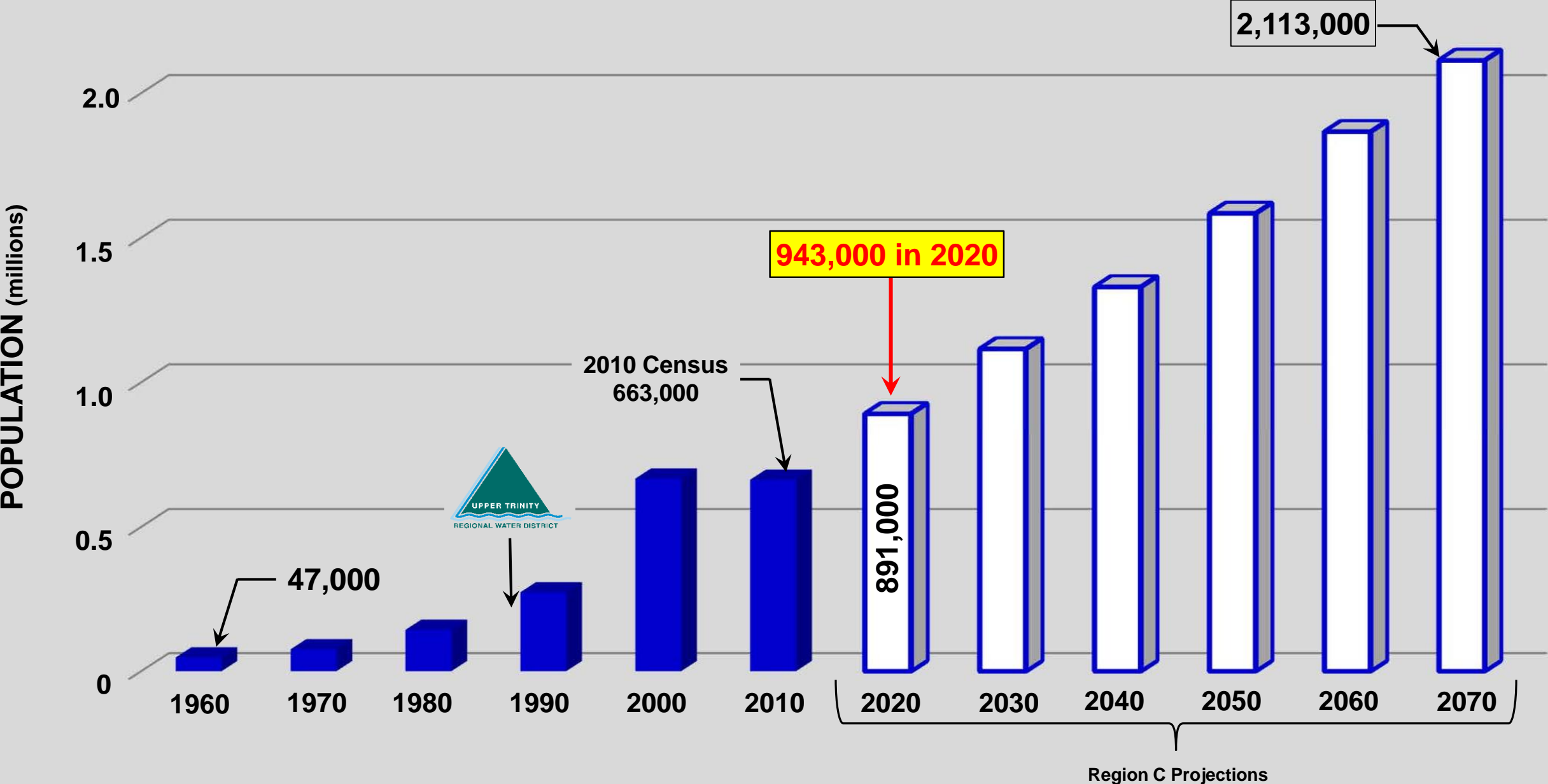

Upper Trinity Regional Water District Members and Customers

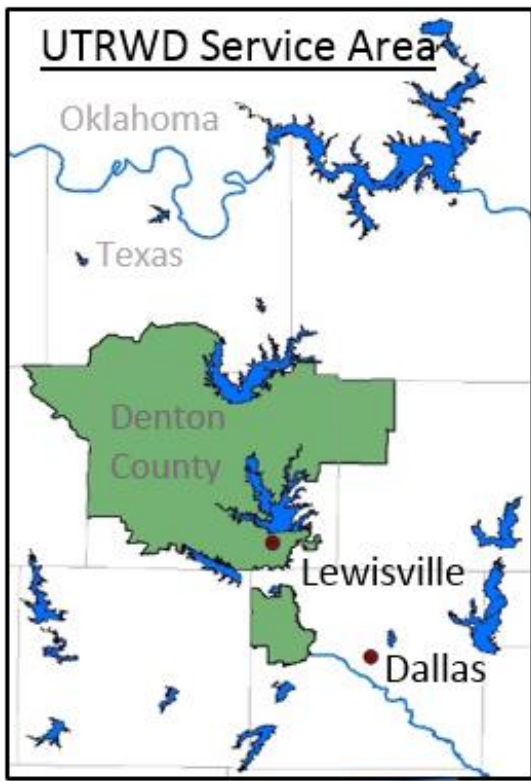

Argyle

Argyle WSC

Aubrey

Bartonville

Celina

Copper Canyon

Corinth

Cross Timbers WSC

Denton

Denton County

DCFWSD # 1A

DCFWSD # 7

DCFWSD # 8A

DCFWSD #10

DCFWSD # 11A

Double Oak

Flower Mound

Highland Village

Irving

Justin

Krum

Lake Cities MUA

Lewisville

Mustang SUD

Northlake

Pilot Point

Ponder

Prosper

Providence Village

Sanger



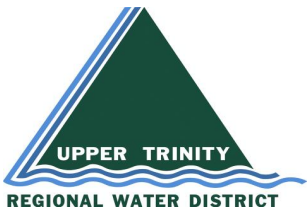

Upper Trinity Regional Water District Water System Service Area & Sources

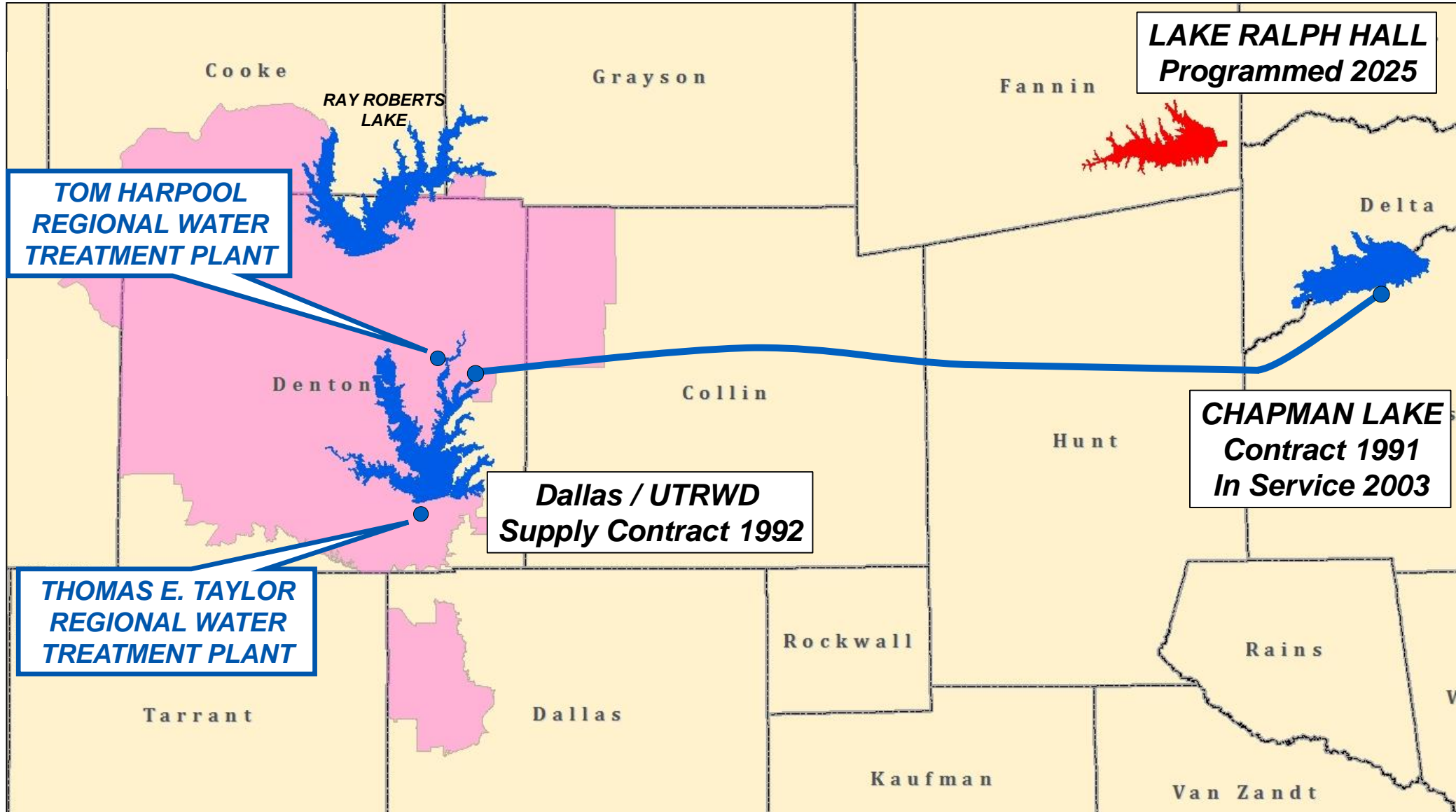

**TOM HARPOOL
REGIONAL WATER
TREATMENT PLANT**

**THOMAS E. TAYLOR
REGIONAL WATER
TREATMENT PLANT**

**Dallas / UTRWD
Supply Contract 1992**

**LAKE RALPH HALL
Programmed 2025**

**CHAPMAN LAKE
Contract 1991
In Service 2003**

Thomas E. Taylor Water Treatment Plant

Joint Lake Intake
City of Lewisville/UTRWD

Existing = 70 mgd
Expandable to 300 mgd

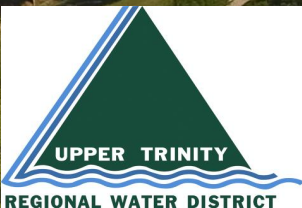



**Current Capacity
20 mgd**

**Expandable to
240 mgd**

Harpool Water Treatment Plant

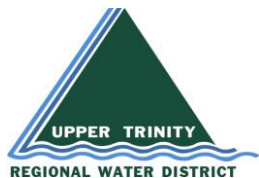

Location: Providence Village, Texas



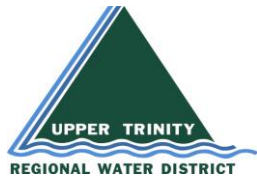

UTRWD Water Reclamation Plants

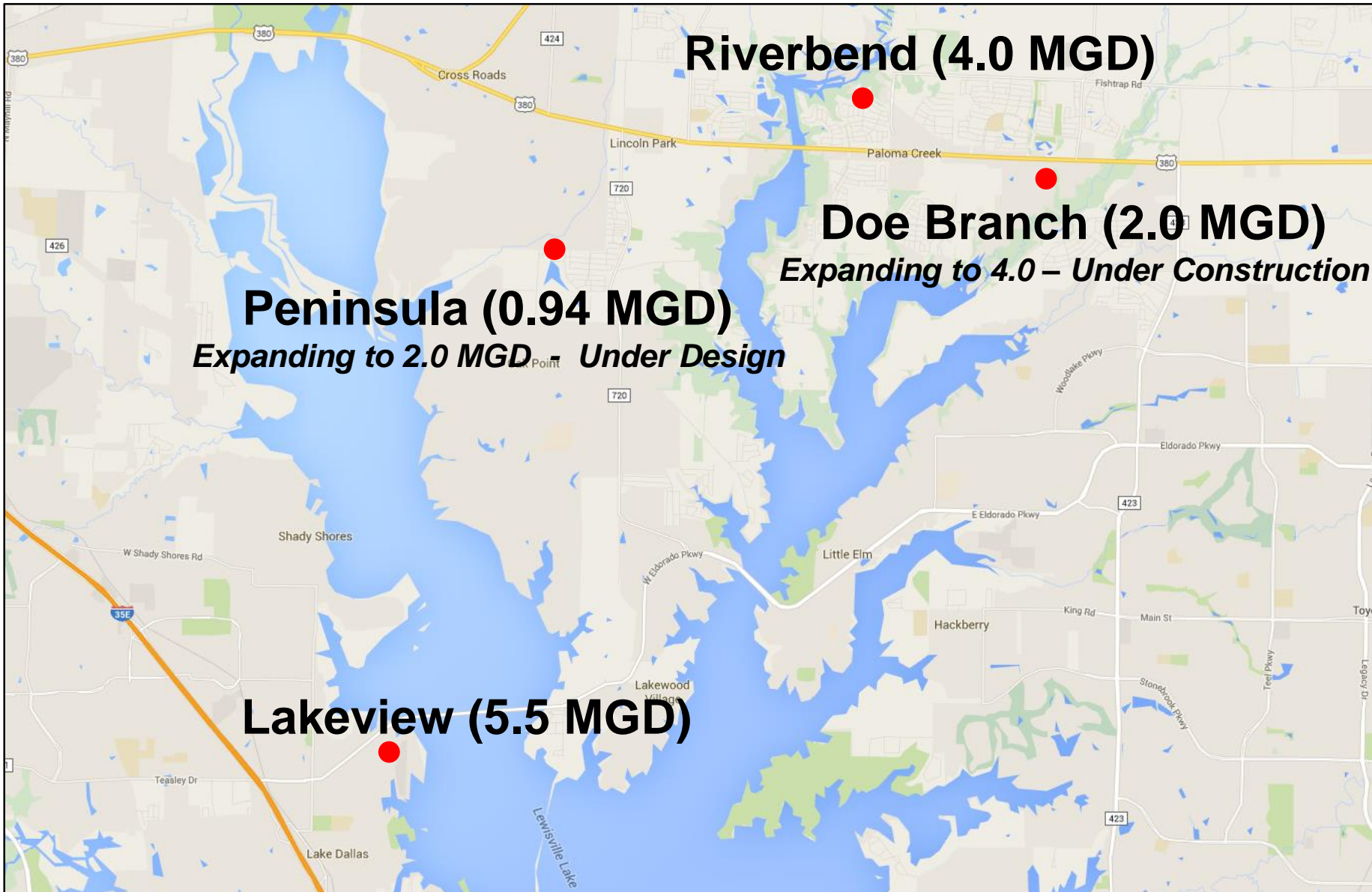

Platinum 20 Award
Lakeview

Platinum 15 Award
Peninsula

Platinum 11 Award
Riverbend

3rd Gold Award
Doe Branch



Operational Awards and Recognition



Best Tasting Water in Texas

- **Thomas E. Taylor WTP**

Best Tasting Membrane Water

- **Tom Harpool WTP**

Outstanding Large Membrane Plant

- **Tom Harpool WTP**

NACWA - National Environmental Achievement Award

- **Riverbend WRP**

WEAT - Municipal Wastewater Treatment Plant of the Year

- **Riverbend WRP**

Budget & Management Recognition



GFOA Distinguished Budget Presentation Award & Special Capital Recognition

NACWA Excellence in Management Program Award

**Denton County Master Gardener's
“Community Partner of the Year”**

TAWWA - - Watermark Award “Outdoor Watering Videos”



Longstanding Relationship

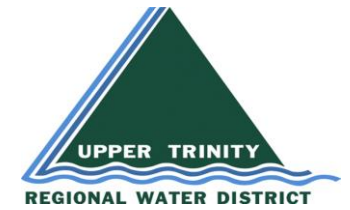

Joint Projects with Lewisville

- Lewisville Lake Raw Water Intake Facility
- Emergency treated water interconnect
- Wastewater Reuse Purchase Contract
- Water service to DCFWSD # 1A (Castle Hills)
- Lewisville Dam Safety Modifications (USACE)
- Communications Tower – – lease agreement



Keep Lewisville Beautiful



Denton County
Greenbelt Plan
For the Future



Coordinated Activities

Joint Water Quality Testing (Lewisville Lake)
Lewisville Water Lab Services
NCTCOG Water Resource Council
Community Garden

Denton County Greenbelt Plan
Water Loss Control Workshops
Keep Lewisville Beautiful
Support to Past - - 4th of July Fireworks

72" Parallel Water Pipeline Project

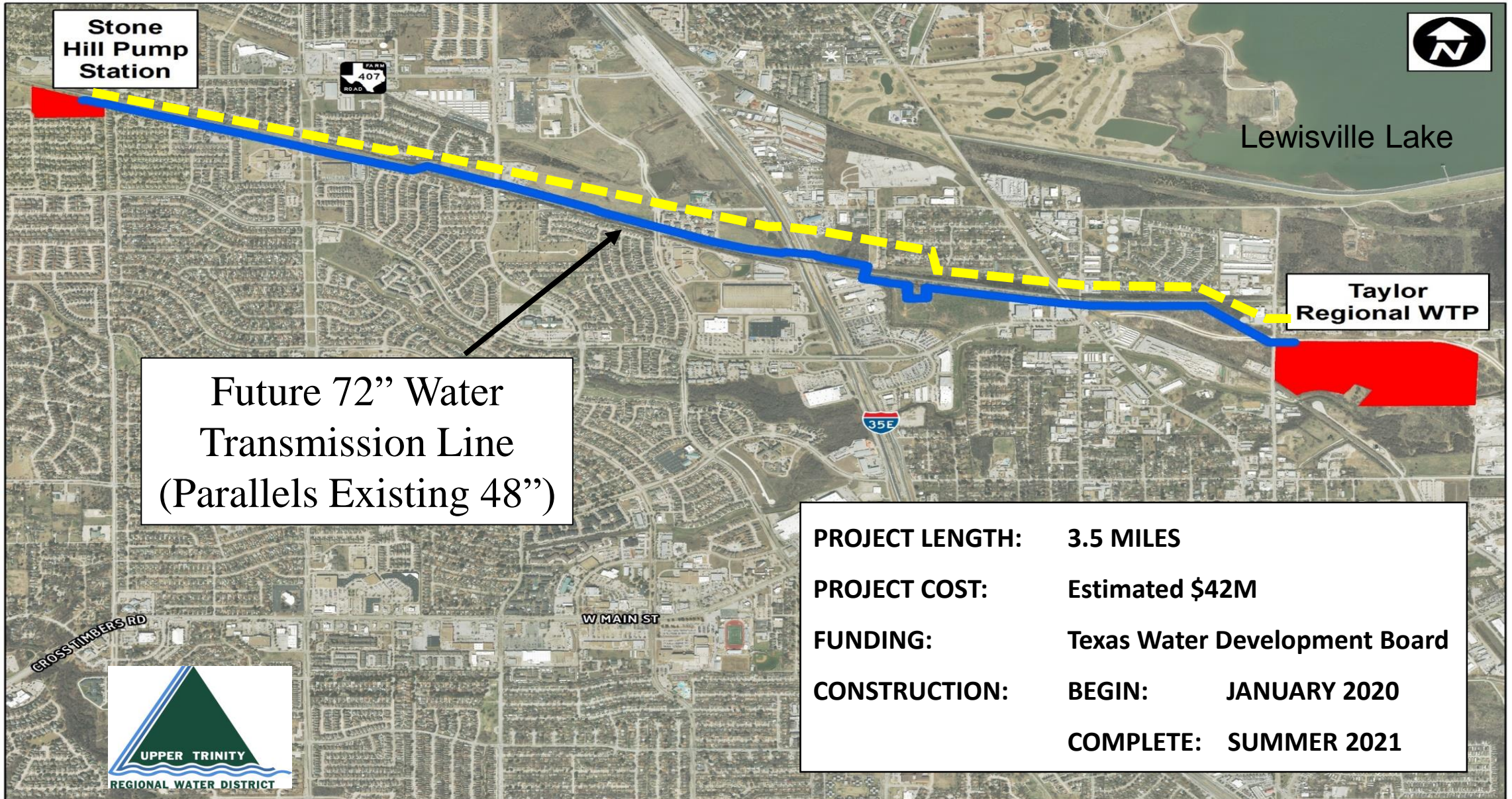

Water Resources Projections

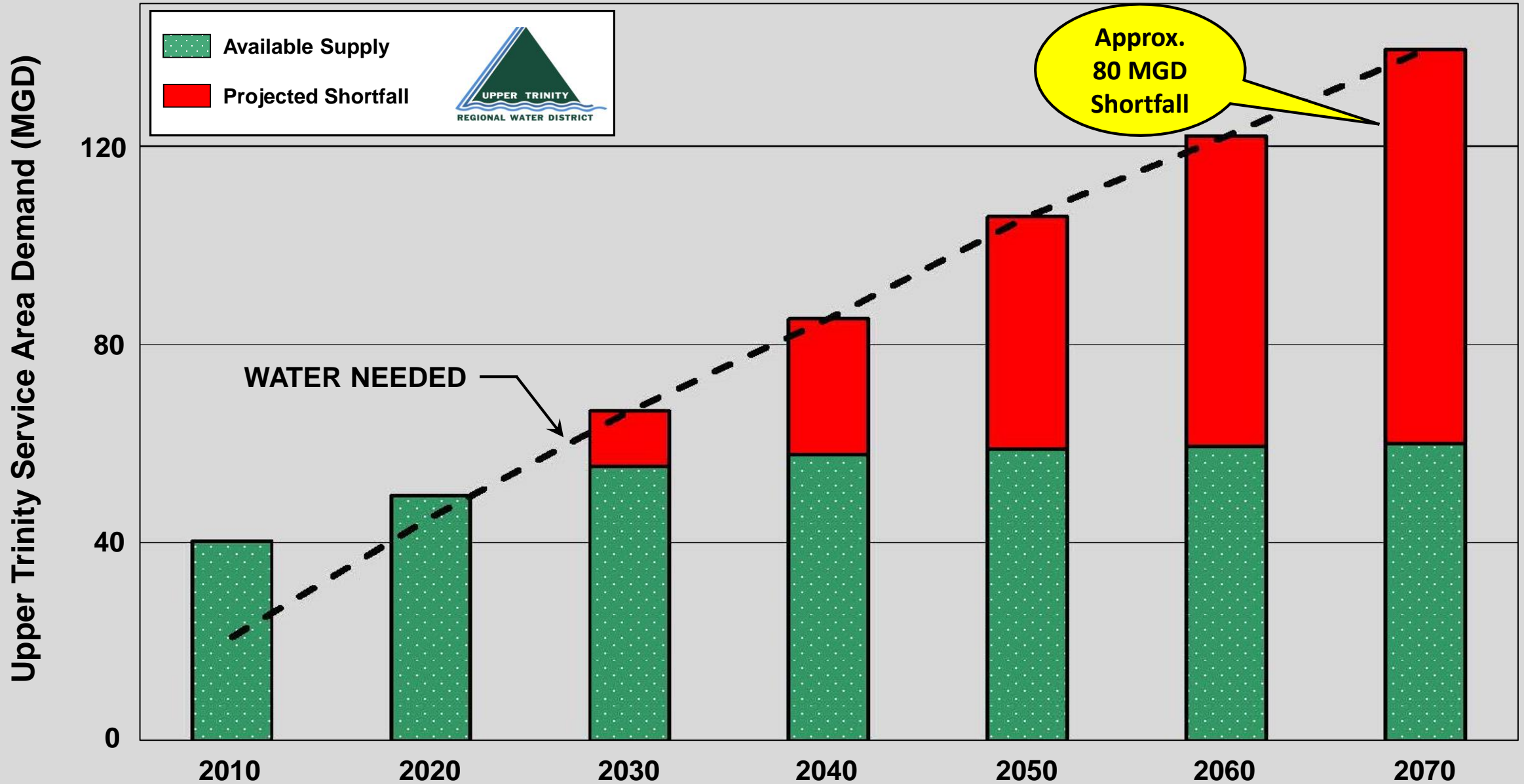

Upper Trinity Regional Water District Water System Service Area & Sources

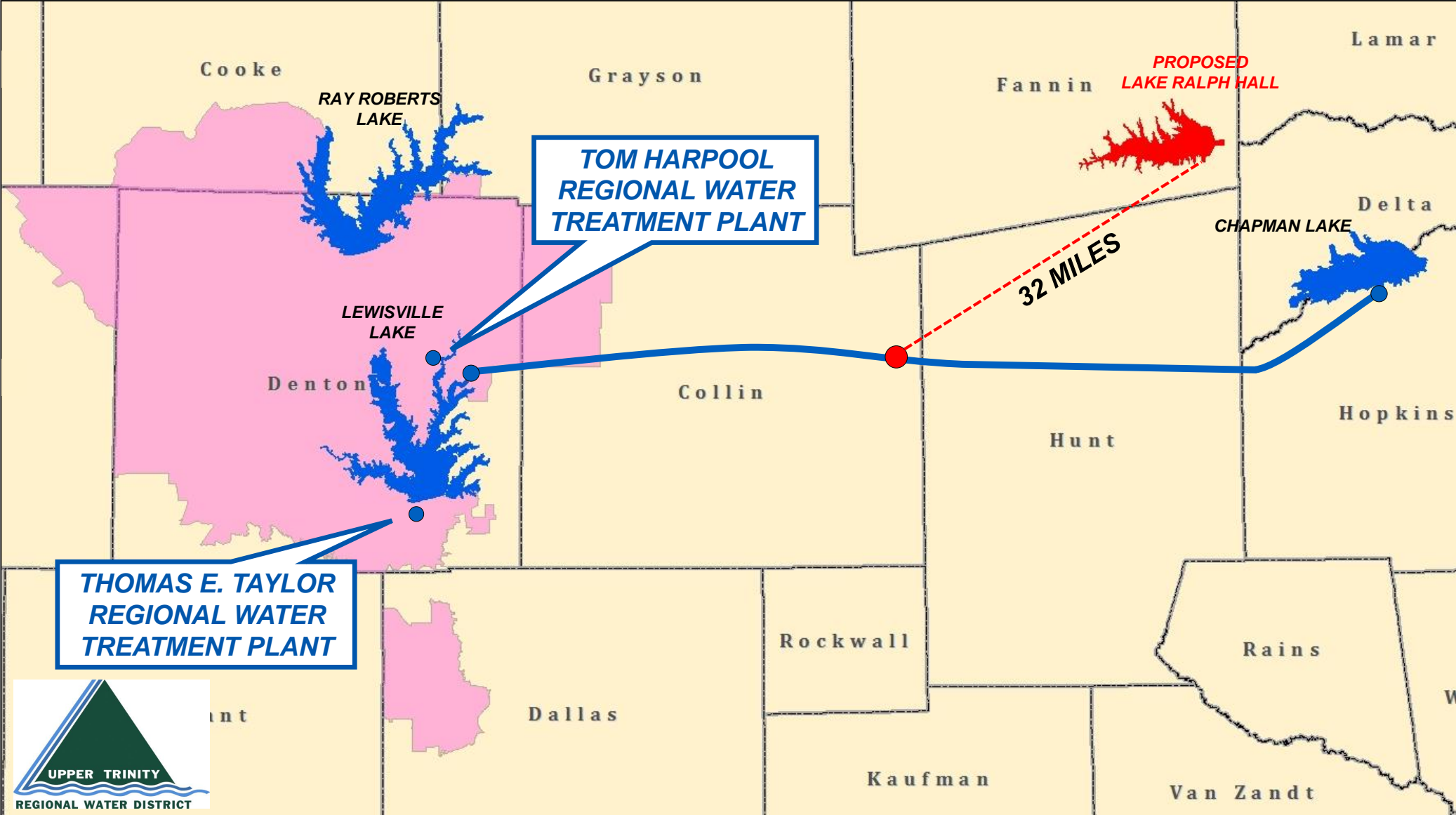

North Sulphur River



- River channelized in the late 1920's
- Agricultural Project
- Intended to improve drainage

Original Channel Cross-Section
(Approx. 16 feet wide & 10 feet deep)

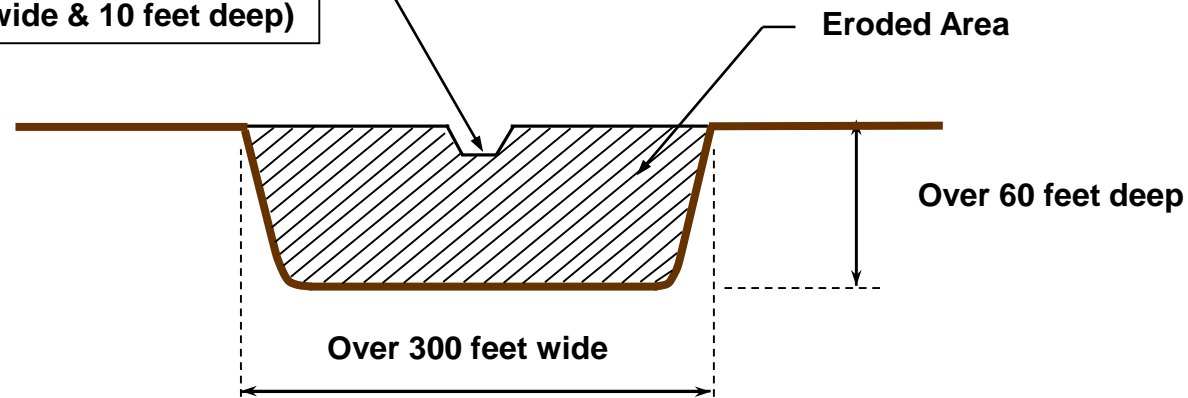

Current Channel Cross-Section



Channel Upstream of Hwy 34 Bridge

Nov. 2008



PROPOSED LAKE RALPH HALL

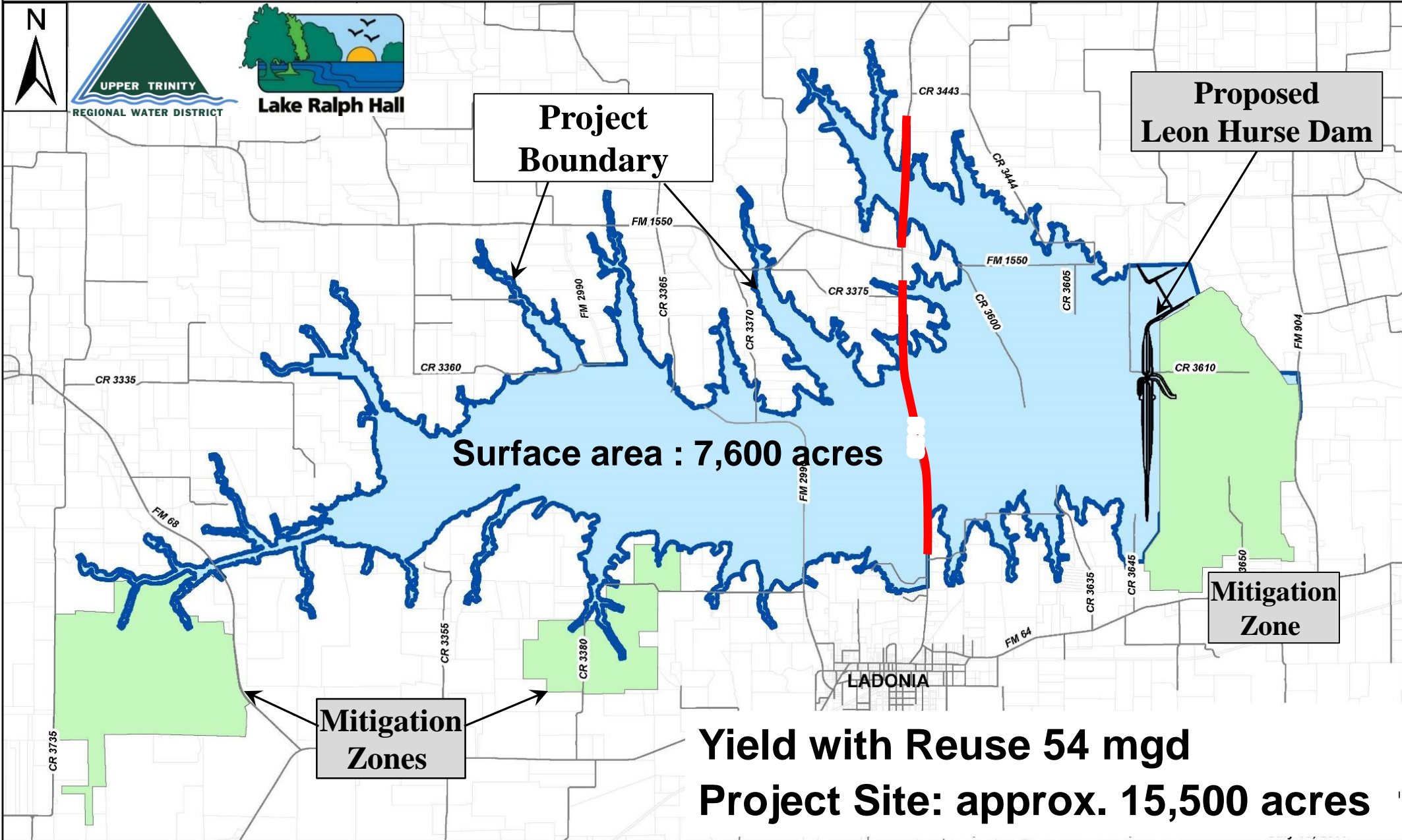

**Project
Boundary**

**Proposed
Leon Hulse Dam**

Surface area : 7,600 acres

**Mitigation
Zone**

**Mitigation
Zones**

**Yield with Reuse 54 mgd
Project Site: approx. 15,500 acres**

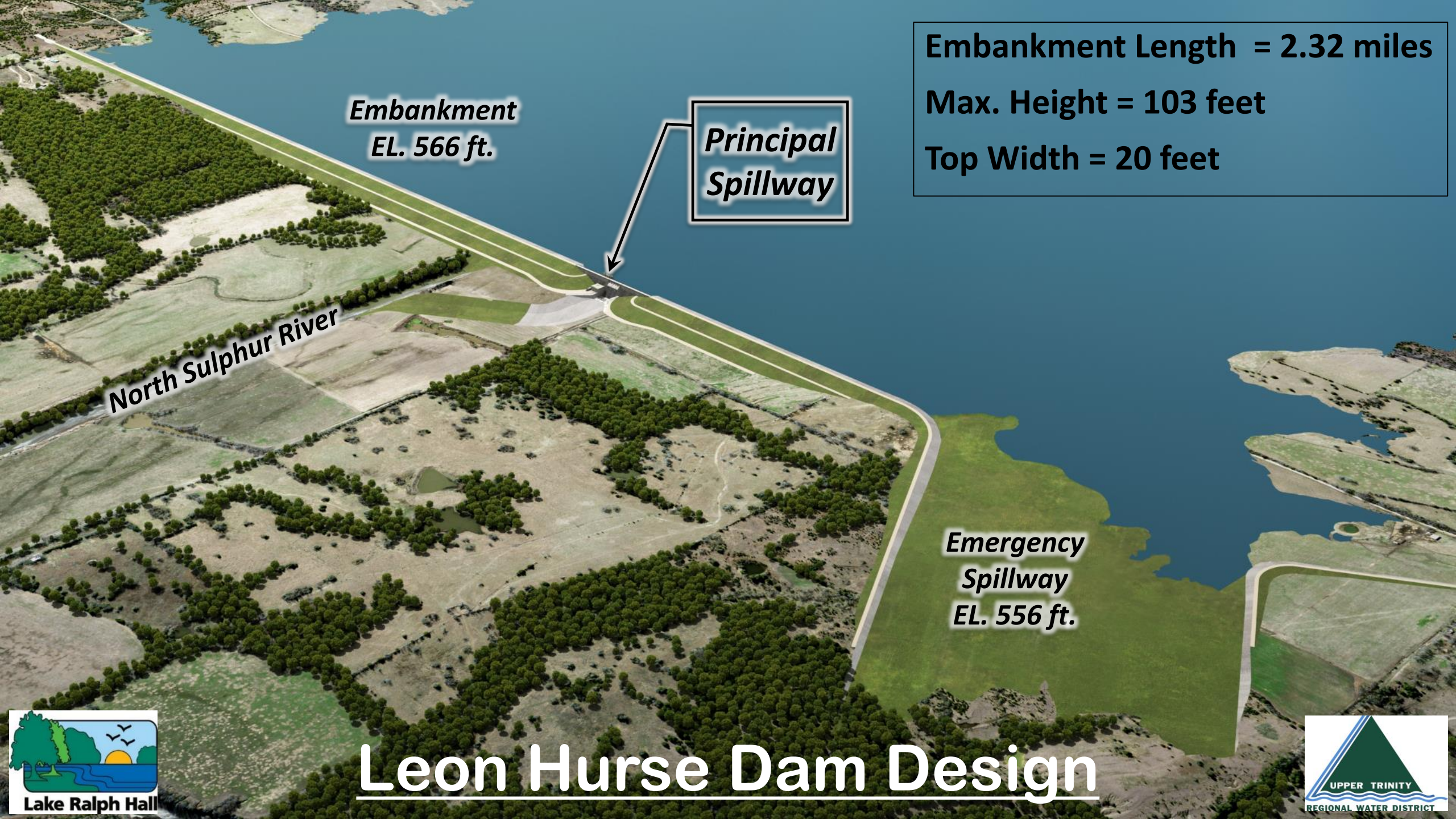

*Embankment
EL. 566 ft.*

**Principal
Spillway**

**Embankment Length = 2.32 miles
Max. Height = 103 feet
Top Width = 20 feet**

North Sulphur River

*Emergency
Spillway
EL. 556 ft.*

Leon Hurse Dam Design

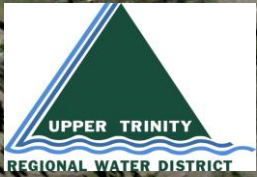

SH 34 Bridge

Length of Bridge = 1.25 miles

Overall Width of Bridge Section = 58 ft.

Min. Clearance over Main Channel = 40 ft.

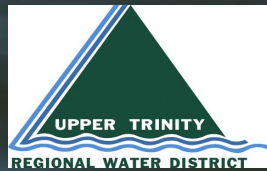
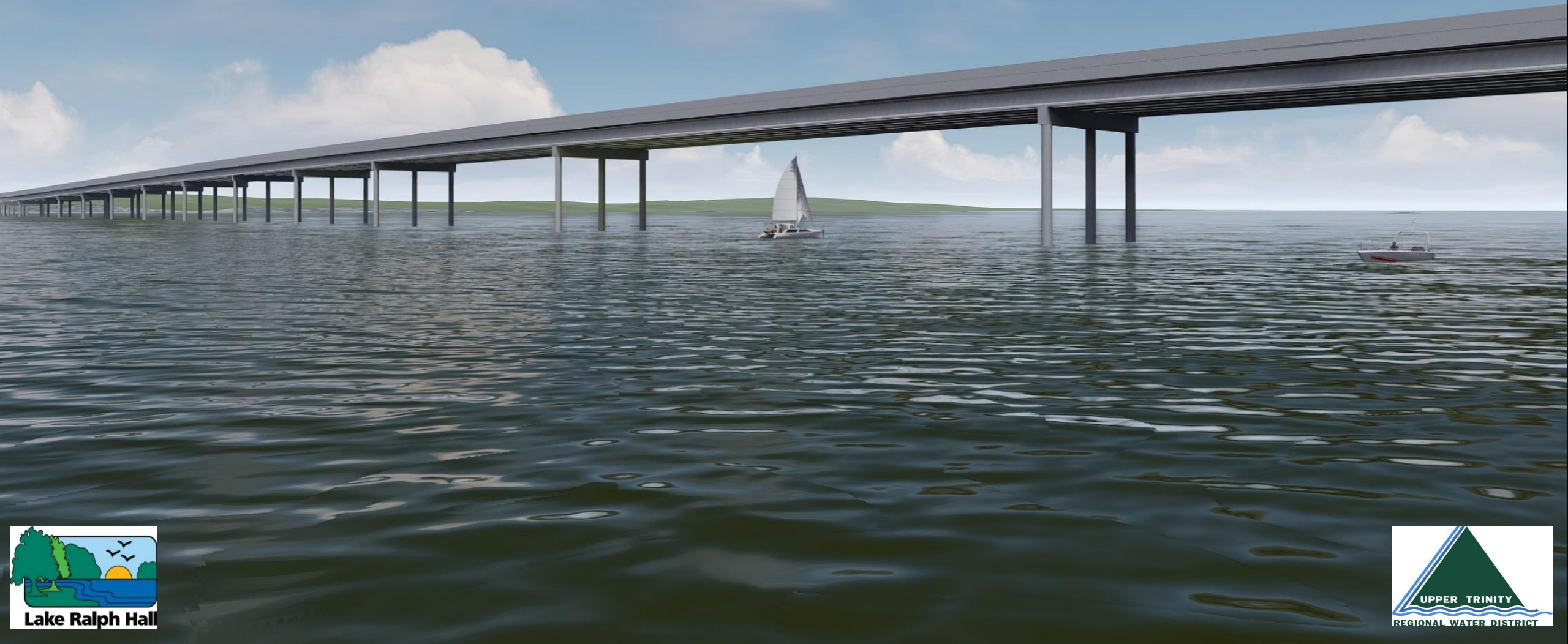

LAKE RALPH HALL CONVEYANCE SYSTEM

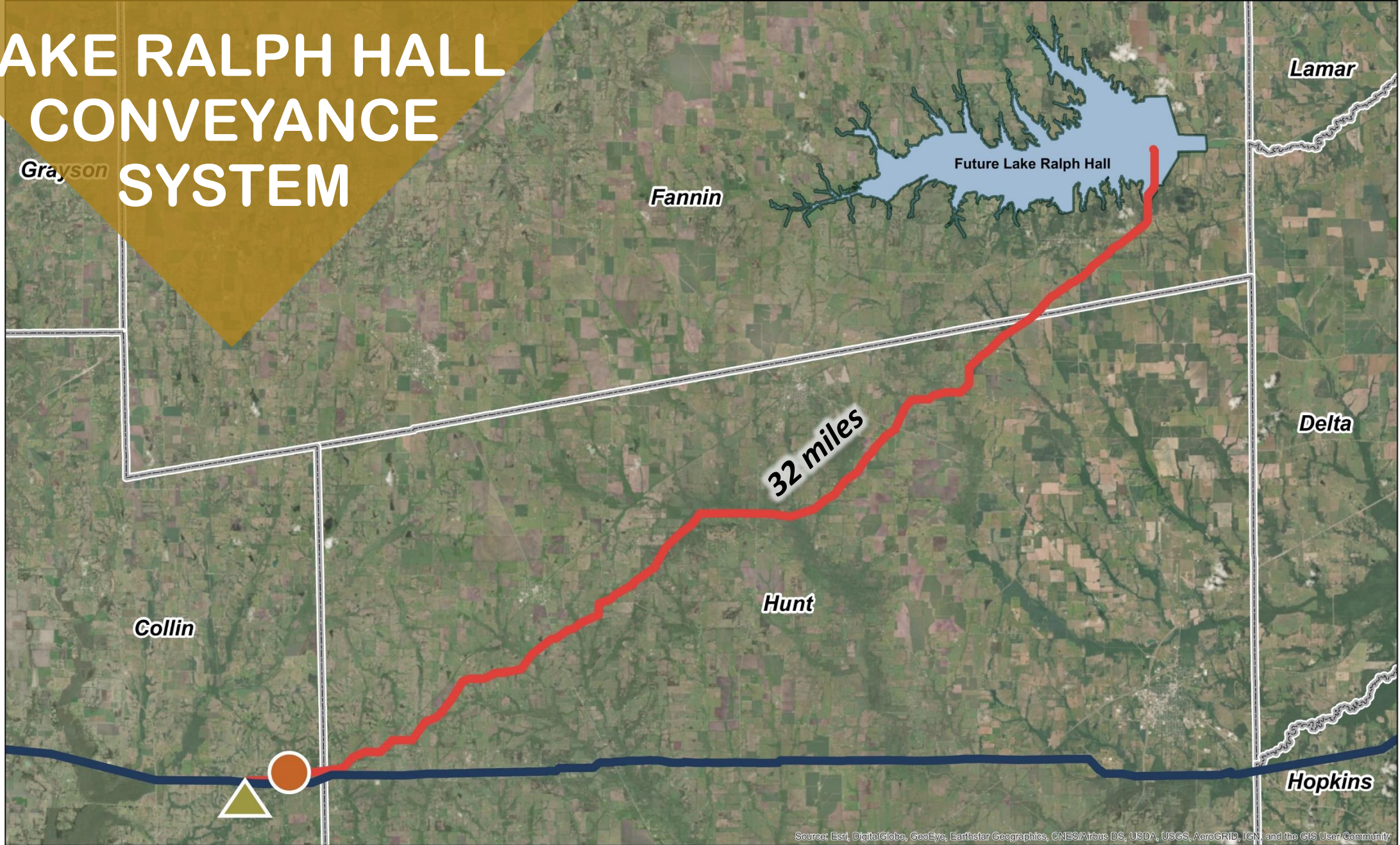

Source: Esri, DigitalGlobe, GeoEye, Earthstar Geographics, CNES/Airbus DS, USDA, USGS, AeroGRID, IGN, and the GIS User Community



— Proposed Lake Ralph Hall Pipeline
— Existing Chapman Lake Pipeline

● Existing Irving Balancing Reservoir and Proposed Lake Ralph Hall Balancing Reservoir
▲ Existing Irving Pump Station



Next Steps for Lake Ralph Hall

- **Acquire Federal 404 Construction Permit**
- **Receive Texas Water Development Funding**
- **Continue Land Acquisition Program**
- **Prepare Final Design & Construct Project**





Lake Ralph Hall Schedule

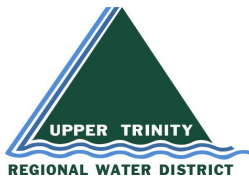

2001 2002 2003 2004 2005 2006 2007 2008 2009 2010 2011 2012 2013 2014 2015 2016 2017 2018 2019 2020 2021 2022 2023 2024 2025

**Planning
2 Years**

**State & Federal Permitting
17 Years**

**Land Acquisition
15 Years**

**Design
7 Years**

**Construction
5 Years**

**Filling
3 Years**

***“Water for the People
it Takes Leadership”***

Future Coordination - - Opportunities

- **Water Supply Planning**
- **Risk Assessment & Resilience Programs**
- **Roadway / TxDOT Projects**
- **State / Federal Utility Regulatory Review**
- **Legislative Activities**
- **Expanded Emergency Interconnections**
- **Castle Hills (DCFWSO #1A) Annexation**
 - **Needs Evaluation**
 - **Contract Assignment(s)**

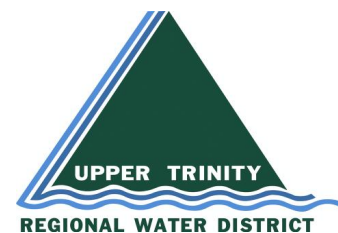

With Vision and Courage, We Plan



Upper Trinity is committed to reliable long-term water supply, adequate for the District's service area.

Questions

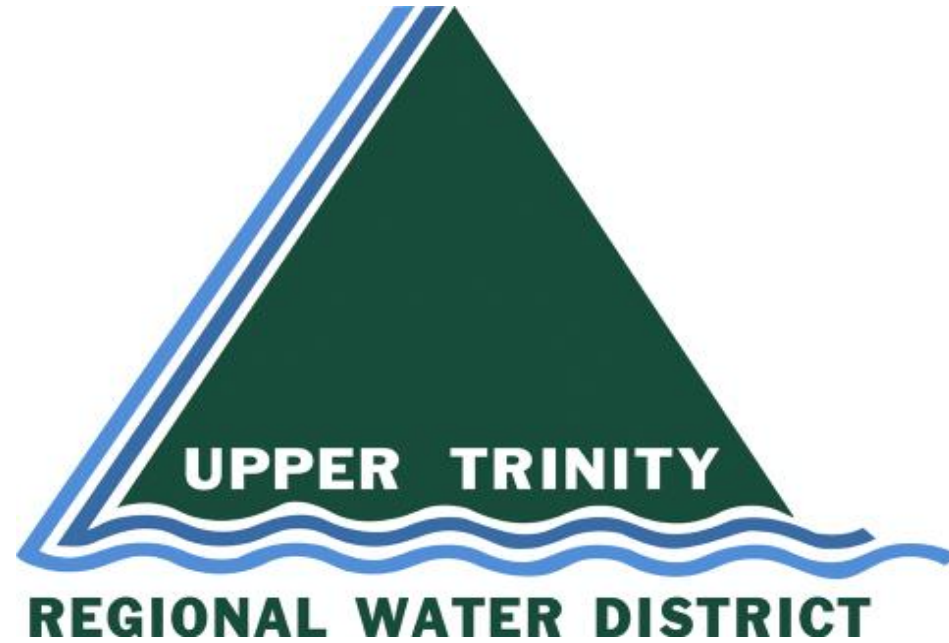

www.lakeralphhallinfo.com

[\(972\) 219-1228](tel:(972)219-1228)



LEWISVILLE

Deep Roots. Broad Wings. Bright Future.

CITY OF LEWISVILLE BUILDING & FIRE CODE UPDATE

FEBRUARY 3, 2020

UPDATES TO THE FOLLOWING CHAPTERS:

- **Chapter 4 – Buildings and Building Regulations**
 - Article II. – Building Standards
 - Article III. – Electrical Standards
 - Article IV. – Plumbing Standards
 - Article V. – Mechanical Standards
- **Chapter 5 – Fire Prevention and Protection**
 - Article III. – Fire Prevention Standards
- **Chapter 9 – Nuisances**
 - Article IV. – Property Maintenance Code



LEWISVILLE

Deep Roots. Broad Wings. Bright Future.

CODE ADOPTIONS:

- 2018 International Building Code
- 2018 International Fire Code
- 2018 International Residential Code
- 2018 International Plumbing Code
- 2018 International Fuel Gas Code
- 2018 International Mechanical Code
- 2018 International Energy Conservation Code
- 2018 International Existing Building Code
- 2018 International Property Maintenance Code
- 2017 National Electrical Code (NFPA 70)

The model codes are published on a three-year cycle by the International Code Council and the National Fire Protection Agency.

NCTCOG publishes recommended regional amendments based on local practices and conditions.





WHY DO WE HAVE CODES?

- ❑ To establish the minimum requirements to safeguard:
 - The public health, safety and general welfare through structural strength, means of egress, stability, sanitation, adequate light and ventilation, energy conservation, and safety
 - Life and property from fire and other hazards (*wind, flooding, freezing, moisture*) attributed to the built environment
- ❑ To provide safety to fire fighters and emergency responders during emergency operations.



LEWISVILLE
Deep Roots. Broad Wings. Bright Future.

SIGNIFICANT CHANGE: TOWNHOME SEPARATION

CHANGE SUMMARY: Two paths are provided to achieve the required fire-rated separation between townhome units: two 1-hours walls or a common wall.

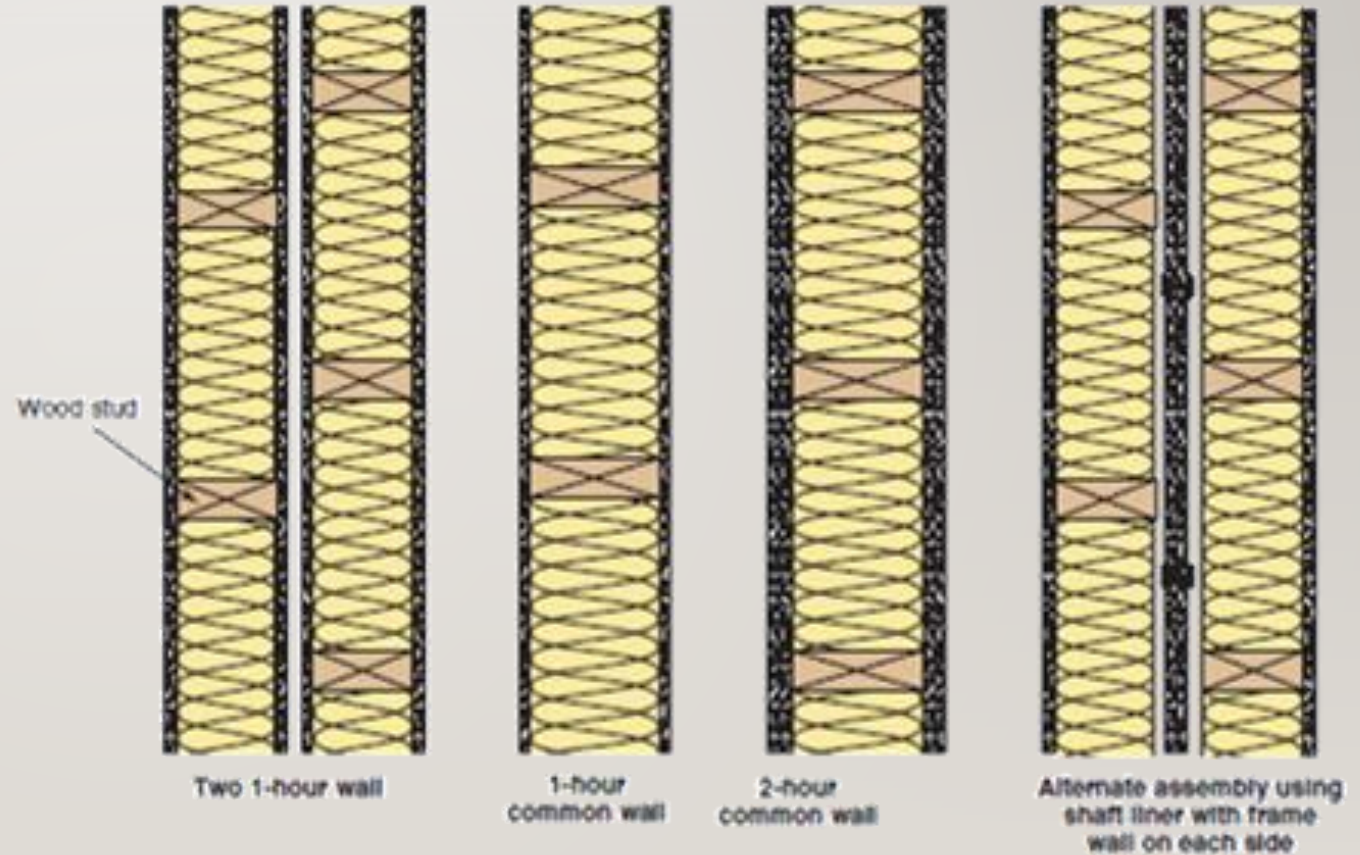



LEWISVILLE
Deep Roots. Broad Wings. Bright Future.

SIGNIFICANT CHANGE: ROOF ACCESS FOR PHOTOVOLTAIC SYSTEMS

CHANGE SUMMARY: Requirements for roof access and pathways for firefighters have been introduced for residential rooftop-mounted photovoltaic solar energy systems.

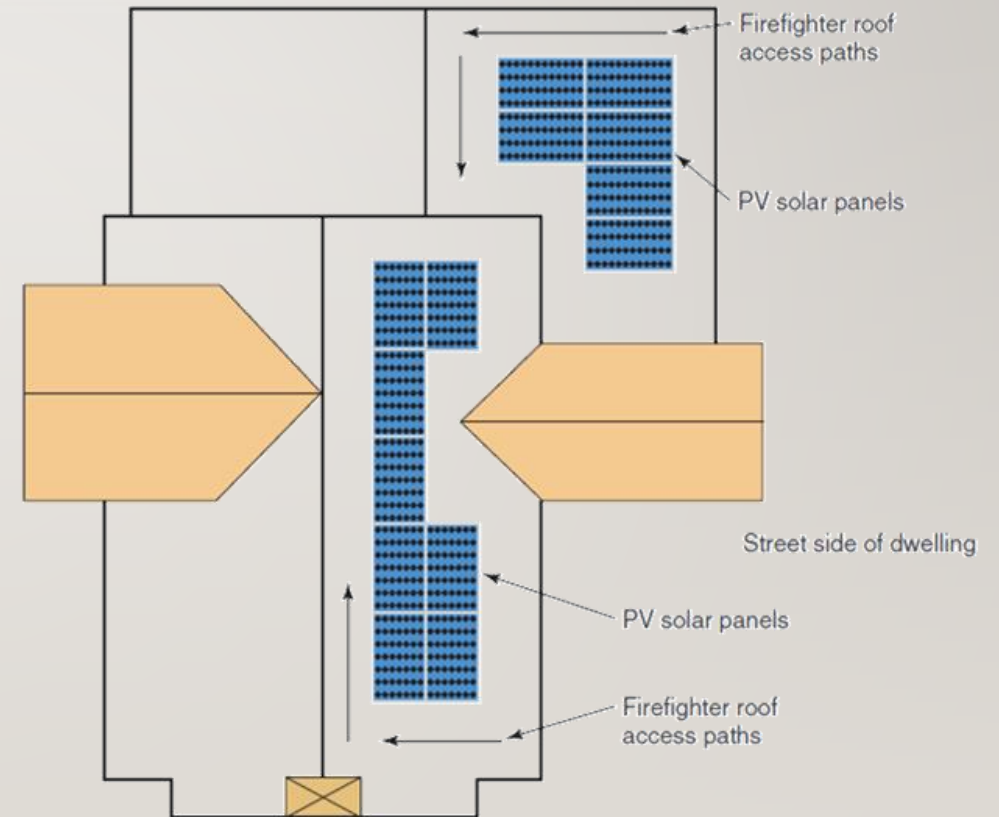



LEWISVILLE
Deep Roots. Broad Wings. Bright Future.

SIGNIFICANT CHANGE: SMOKE ALARMS IN RESIDENTIAL REMODELS

CHANGE SUMMARY: Smoke alarms must be retroactively installed per current code when work requiring a permit is performed. The exception to require interconnection between devices only when feasible has been removed. Interconnection is now always required.





LEWISVILLE
Deep Roots. Broad Wings. Bright Future.

SIGNIFICANT CHANGE: RESIDENTIAL LIGHTING

CHANGE SUMMARY: The required percentage of permanent lighting fixtures having high-efficacy lamps (e.g., LED and CFL lamps) has increased from 75% to 90%. Incandescent and halogen bulbs don't qualify.





LEWISVILLE
Deep Roots. Broad Wings. Bright Future.

SIGNIFICANT CHANGE: RESIDENTIAL ELECTRICAL SERVICE DISCONNECT

CHANGE SUMMARY: The electrical service disconnecting means shall be located on the exterior of the house nearest the point of entrance of the service conductors. (Local amendment.)





LEWISVILLE
Deep Roots. Broad Wings. Bright Future.

SIGNIFICANT CHANGE: ELEVATOR DOORS IN FIRE-RATED CORRIDOR

CHANGE SUMMARY: When an elevator door opens into a fire-rated corridor, the door must be protected by the use of elevator lobbies, additional doors, or pressurized hoistway.





LEWISVILLE
Deep Roots. Broad Wings. Bright Future.

SIGNIFICANT CHANGE: LOCKS IN EDUCATIONAL OCCUPANCIES

CHANGE SUMMARY: Enhanced security measures on educational classroom egress doors has been provided.

Doors may be locked from the classroom side by use of a key or remote operation if door will unlock during normal operation.





LEWISVILLE
Deep Roots. Broad Wings. Bright Future.

SIGNIFICANT CHANGE: SINGLE-USE TOILET FACILITIES

CHANGE SUMMARY: Single-user toilet facilities must now be labeled for use by either sex. (Previously, facilities were required to be labeled either male or female.)





LEWISVILLE
Deep Roots. Broad Wings. Bright Future.

SIGNIFICANT CHANGE: FOOD WASTE DISPOSER DISCHARGE

CHANGE SUMMARY: Food waste disposer discharge to any type of grease interceptor is prohibited. (Previously, a solids interceptor could be installed between a disposer and grease interceptor.)

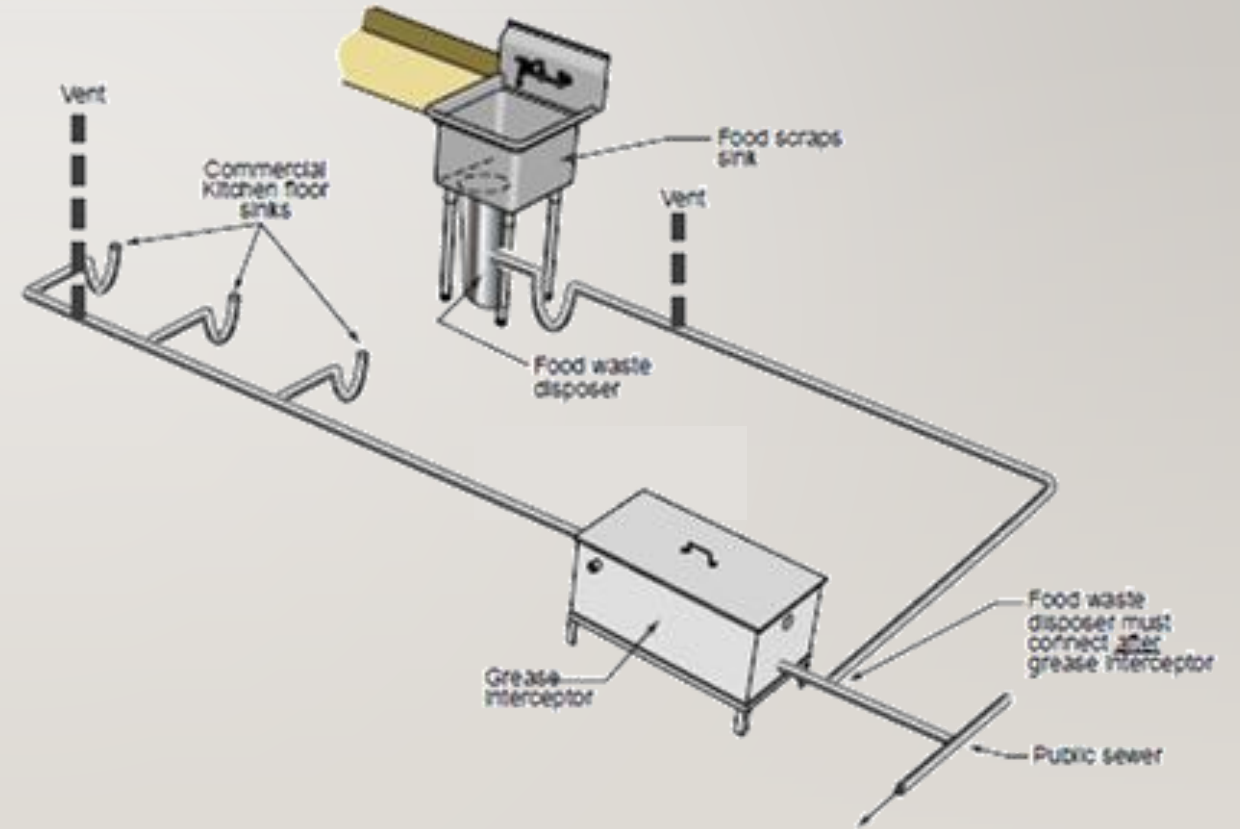



SIGNIFICANT CHANGE: RESIDENTIAL ENERGY CONSERVATION

Comparing a new house under the 2009 IECC to the 2018 IECC (as adopted):

- ❑ The average homeowner in our climate zone (3A) will save:
 - \$385.36 per year in energy costs (or a cost savings of 22.1%)
 - \$5,517.37 or more will be the average life-cycle (30 years) cost savings, adjusted with anticipated inflation rate

- ❑ The average increase in construction costs:
 - For a slab-on-grade house is \$2,209.52, which will increase the average mortgage by \$69.37/year
 - It will take 3.7 years to pay back the extra cost of construction (cost increase vs energy savings)

(Source: U.S. Department of Energy, *Cost-Effective Analysis of the Residential Provisions of the 2015 IECC for Texas*, February 2016)



LEWISVILLE

Deep Roots. Broad Wings. Bright Future.

FIRE PROTECTION FOR OPEN PARKING GARAGES

APARTMENT COMPLEX PARKING GARAGE HOUSTON, TX

[Hampstead Apartments Houston, Tx](#)





CURRENT CODE

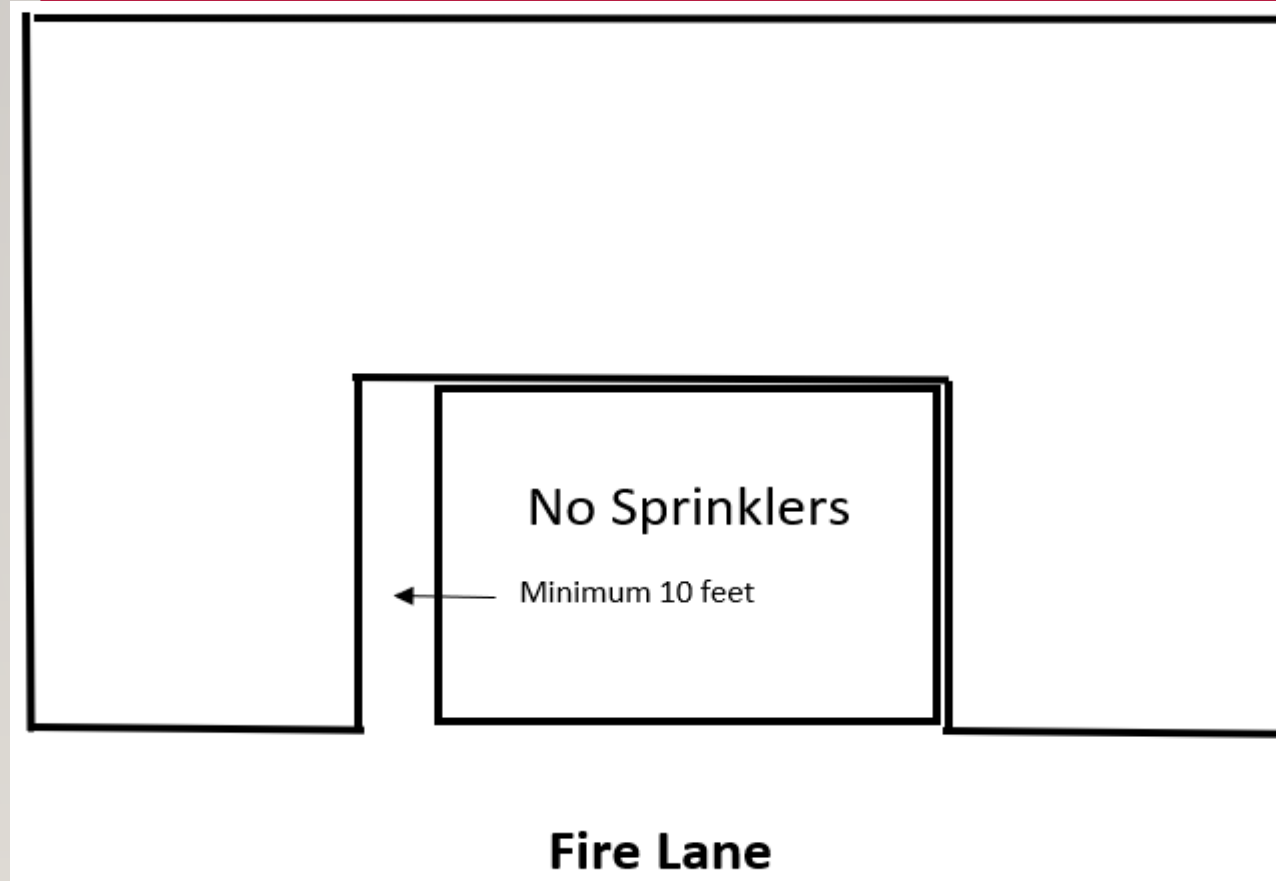

- Open parking garage is **not protected with fire sprinklers**.
- Minimum separation between buildings is 10-feet on two sides.



EXCEPTION

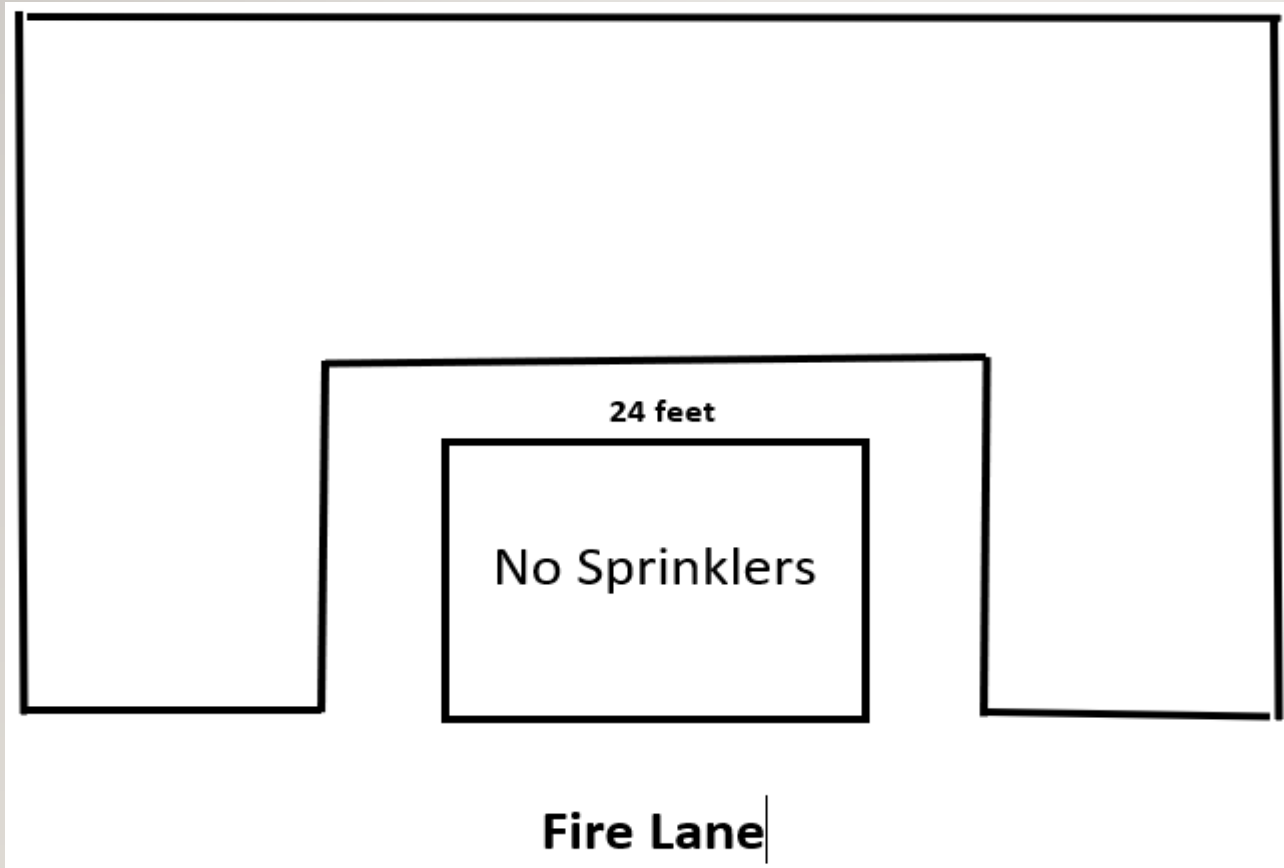

- Open parking garage is **not protected with fire sprinklers**.
- Minimum separation between buildings is **24 feet allowing for a fire lane**.
- Allow for alternative surfaces such as grasscrete.
- Could add amenities such as benches, etc.

SURVEY CITIES

City	No Sprinklers	Require Sprinklers	Conditions
Frisco		X	If attached. Attached is less than 10 feet.
McKinney		X	Fire lane around entire parking structure or sprinklers
Flower Mound	X		
The Colony	X		
Coppell	X		
Grapevine		X	Any size open or enclosed structure
Farmers Branch		X	Same as Plano--2 sides
Plano		X	Fire Lane on 2 sides and 150 foot hoseline requirement or variance granted with fire sprinklers.
Arlington	X		
Carrollton	X		
Dallas	X		
Ft Worth	X		
Garland	X		
Grand Prairie	X		
Irving	X		
Denton	X		
Mesquite	X		
Richardson	X		



COST FOR FIRE SPRINKLER SYSTEMS

\$1 - \$2 per
square foot.

Aura Old Town –
120,000 SF @
\$1.50/SF equals
\$180,000.

Tower Bay (actual
cost) 175,955 SF
@ \$1.40/SF
equals \$246,377.



LEWISVILLE
Deep Roots. Broad Wings. Bright Future.

QUESTIONS?

Jeremy Booker, Building Official

jbooker@cityoflewisville.com

(972) 219-3471

Tim Ippolito, Fire Marshal

tippolito@cityoflewisville.com

(972) 219-3466