

STRUCTURAL DESIGN

ENCLOSED BUILDING

**MAXIMUM 30'- 0" WIDE X 20'- 0" HEIGHT-
BOX EAVE FRAME AND BOW FRAME**

27 May 2021
Revision 01
M&A Project No. 19262S

Prepared for:

Texas Metal Carports

Prepared by:

Moore and Associates Engineering and Consulting, Inc.

**1009 East Avenue
North Augusta, SC 29841**

**401 S. Main Street, Suite 200
Mount Airy, NC 27030**

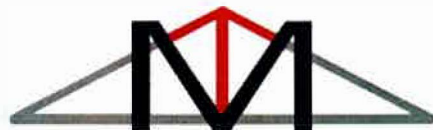

MOORE AND ASSOCIATES
ENGINEERING AND CONSULTING



**528 Degan Ave
Lewisville, Texas 75057**

528 Degan Ave
Lewisville, Texas 75057



MOORE AND ASSOCIATES
ENGINEERING AND CONSULTING, INC.

DRAWN BY: AST
CHECKED BY: PDH

30' -0"x20'-0" ENCLOSED STRUCTURE

THIS DOCUMENT IS THE PROPERTY OF MOORE AND ASSOCIATES ENGINEERING AND CONSULTING. THE UNAUTHORIZED REPRODUCTION, COPYING, OR OTHERWISE USE OF THIS DOCUMENT IS STRICTLY PROHIBITED AND ANY INFRINGEMENT THEREUPON MAY BE SUBJECT TO LEGAL ACTION.

PROJECT MGR: WSN
SHT. 1

DATE: 11-11-19
SCALE: NTS
DWG. NO: SK-3

JTB. NO. 18262S
REV: 0

DRAWING INDEX

SHEET 1	PE SEAL COVER SHEET (1 OF 2)
SHEET 2	DRAWING INDEX
SHEET 3	INSTALLATION NOTES AND SPECIFICATIONS
SHEET 4	TYPICAL END AND SIDE ELEVATIONS
SHEET 5	TYPICAL RAFTER/COLUMN END AND SIDE FRAMING SECTION (BOX EAVE RAFTER) (EXPOSURE B)
SHEET 5A	TYPICAL RAFTER/COLUMN END AND SIDE FRAMING SECTION (BOX EAVE RAFTER) (EXPOSURE B)
SHEET 5B	TYPICAL RAFTER/COLUMN END AND SIDE FRAMING SECTION (BOX EAVE RAFTER) (EXPOSURE B)
SHEET 5C	TYPICAL RAFTER/COLUMN END AND SIDE FRAMING SECTION (BOX EAVE RAFTER) (EXPOSURE C)
SHEET 5D	TYPICAL RAFTER/COLUMN END AND SIDE FRAMING SECTION (BOX EAVE RAFTER) (EXPOSURE C)
SHEET 5E	TYPICAL RAFTER/COLUMN END AND SIDE FRAMING SECTION (BOX EAVE RAFTER) (EXPOSURE C)
SHEET 6	COLUMN CONNECTION DETAILS (BOX EAVE STRUCTURE) (EXPOSURE B)
SHEET 6A	COLUMN CONNECTION DETAILS (BOX EAVE STRUCTURE) (EXPOSURE B)
SHEET 6B	COLUMN CONNECTION DETAILS (BOX EAVE STRUCTURE) (EXPOSURE C)
SHEET 6C	COLUMN CONNECTION DETAILS (BOX EAVE STRUCTURE) (EXPOSURE C)
SHEET 7	TYPICAL RAFTER/COLUMN END AND SIDE FRAMING SECTION (BOX RAFTER) (EXPOSURE B)
SHEET 7A	TYPICAL RAFTER/COLUMN END AND SIDE FRAMING SECTION (BOX EAVE RAFTER) (EXPOSURE B)
SHEET 7B	TYPICAL RAFTER/COLUMN END AND SIDE FRAMING SECTION (BOX EAVE RAFTER) (EXPOSURE B)
SHEET 7C	TYPICAL RAFTER/COLUMN END AND SIDE FRAMING SECTION (BOX EAVE RAFTER) (EXPOSURE C)
SHEET 7D	TYPICAL RAFTER/COLUMN END AND SIDE FRAMING SECTION (BOX EAVE RAFTER) (EXPOSURE C)
SHEET 7E	TYPICAL RAFTER/COLUMN END AND SIDE FRAMING SECTION (BOX EAVE RAFTER) (EXPOSURE C)
SHEET 8	COLUMN CONNECTION DETAILS (BOX RAFTER STRUCTURE) (EXPOSURE B)
SHEET 8A	COLUMN CONNECTION DETAILS (BOX RAFTER STRUCTURE) (EXPOSURE B)
SHEET 8B	COLUMN CONNECTION DETAILS (BOX RAFTER STRUCTURE) (EXPOSURE C)
SHEET 8C	COLUMN CONNECTION DETAILS (BOX RAFTER STRUCTURE) (EXPOSURE C)
SHEET 9	BASE RAIL ANCHORAGE OPTIONS
SHEET 10	TYPICAL END WALL AND SIDE WALL FRAMING SECTIONS (BOX EAVE RAFTER)
SHEET 11	TYPICAL END WALL AND SIDE WALL FRAMING SECTIONS (BOX RAFTER)
SHEET 12	CONNECTION DETAILS
SHEET 13	CONNECTION DETAILS
SHEET 14	LEAN-TO OPTIONS (BOX EAVE RAFTER)
SHEET 14A	LEAN-TO OPTIONS (BOX EAVE RAFTER)
SHEET 15	LEAN-TO OPTIONS (BOX RAFTER)
SHEET 15A	LEAN-TO OPTIONS (BOX RAFTER)
SHEET 16	VERTICAL ROOF/SIDING OPTION END AND SIDE ELEVATION AND SECTION
SHEET 17	HEADER OPTION



**528 Degan Ave
Lewisville, Texas 75057**

MOORE AND ASSOCIATES ENGINEERING AND CONSULTING, INC.	DRAWN BY: AST	30'-0" x 20'-0" ENCLOSED STRUCTURE		
	CHECKED BY: PDH			
THIS DOCUMENT IS THE PROPERTY OF MOORE AND ASSOCIATES ENGINEERING AND CONSULTING. THE UNAUTHORIZED REPRODUCTION, COPYING, OR OTHERWISE USE OF THIS DOCUMENT IS STRICTLY PROHIBITED AND ANY INFRINGEMENT THEREUPON MAY BE SUBJECT TO LEGAL ACTION.	PROJECT MGR: WSH	DATE: 11-11-19	SCALE: NTS	JOB NO: 19262S
		SHT. 2	DWG. NO: SK-3	REV: 0

INSTALLATION NOTES AND SPECIFICATIONS

- 1 DESIGN IS FOR MAXIMUM 30'-0" WIDE x 20'-0" EAVE HEIGHT ENCLOSED STRUCTURES
- 2 DESIGN WAS DONE IN ACCORDANCE WITH THE 2018 INTERNATIONAL BUILDING CODE (IBC), 2015 IBC, 2012 IBC AND 2009 IBC.
- 3 DESIGN LOADS ARE AS FOLLOWS:
 - A) DEAD LOAD = 15 PSF
 - B) LIVE LOAD = 12 PSF
 - C) GROUND SNOW LOAD = 20 PSF WITH WELDED RAFTER TIE (W ≤ 30'-0")
= 20 PSF WITH U-CHANNEL PEAK BRACE (W ≤ 24'-0")

NOTE: UNBALANCED SNOW LOADS DUE TO DRIFTING HAVE NOT BEEN EVALUATED
- 4 3-SECOND GUST ULTIMATE WIND SPEED (V_{ULT}) = 145 MPH (NOMINAL WIND SPEED = 112 MPH)
- 5 MAXIMUM RAFTER/COLUMN AND END COLUMN SPACING = 5.0 FEET (UNLESS NOTED OTHERWISE)
- 6 END WALL COLUMNS (POSTS) ARE EQUIVALENT TO SIDE WALL COLUMNS IN SIZE AND SPACING (UNLESS NOTED OTHERWISE)
- 7 RISK CATEGORY I
- 8 WIND EXPOSURE CATEGORY B/C
- 9 SPECIFICATIONS APPLICABLE TO 29 GAUGE METAL PANELS FASTENED DIRECTLY TO 2 1/2" x 2 1/2" - 14 GAUGE TUBE STEEL (TS) FRAMING MEMBERS (UNLESS NOTED OTHERWISE)
- 10 AVERAGE FASTENER SPACING ON-CENTERS ALONG RAFTERS OR HAT CHANNELS AND COLUMNS (INTERIOR OR END) = 10" OC (MAX)
- 11 FASTENERS CONSIST OF #12-14x3/4" SELF-DRILLING FASTENER (SDF), USE CONTROL SEAL WASHER WITH EXTERIOR FASTENERS. SPECIFICATIONS APPLICABLE ONLY FOR MEAN ROOF HEIGHT OF 20 FEET OR LESS, AND ROOF SLOPES OF 14° (3:12 PITCH) OR LESS. SPACING REQUIREMENTS FOR OTHER ROOF HEIGHTS AND/OR SLOPES MAY VARY.
- 12 ANCHORS SHALL BE INSTALLED THROUGH BASE RAIL WITHIN 6" OF EACH COLUMN (LEG)
- 13 STANDARD GROUND ANCHORS (SOIL NAILS) CONSIST OF #4 REBAR W/ WELDED NUT x 36" LONG AND MAY BE USED IN SUITABLE SOIL CONDITIONS. OPTIONAL ANCHORAGE MAY BE USED IN SUITABLE SOILS AND MUST BE USED IN UNSUITABLE SOILS AS NOTED
- 14 WIND FORCES GOVERN OVER SEISMIC FORCES. SEISMIC PARAMETERS ANALYZED ARE:
 SOIL SITE CLASS = D
 RISK CATEGORY I/II/III
 $R = 3.25$ $I_E = 1.0$
 $S_{DS} = 2.039 g$ $V = 0.5W$
 $S_{D1} = 1.258 g$



**528 Degan Ave
Lewisville, Texas 75057**

**MOORE AND ASSOCIATES
ENGINEERING AND CONSULTING, INC.**

DRAWN BY: AST

CHECKED BY: PDH

30' -0"x20'-0" ENCLOSED STRUCTURE

PROJECT MGR: VSM

DATE: 11-11-19

SCALE: NTS

JOB NO: 19262S

SHT. 3

DWG. NO: SK-3

REV: 0

THIS DOCUMENT IS THE PROPERTY OF MOORE AND ASSOCIATES ENGINEERING AND CONSULTING. THE UNAUTHORIZED REPRODUCTION, COPYING, OR OTHERWISE USE OF THIS DOCUMENT IS STRICTLY PROHIBITED AND ANY INFRACTION THEREUPON MAY BE SUBJECT TO LEGAL ACTION.

BOX EAVE FRAME RAFTER STRUCTURE

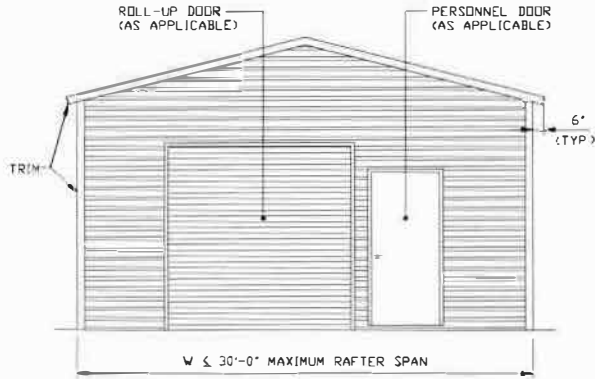

TYPICAL END ELEVATION
SCALE: NTS

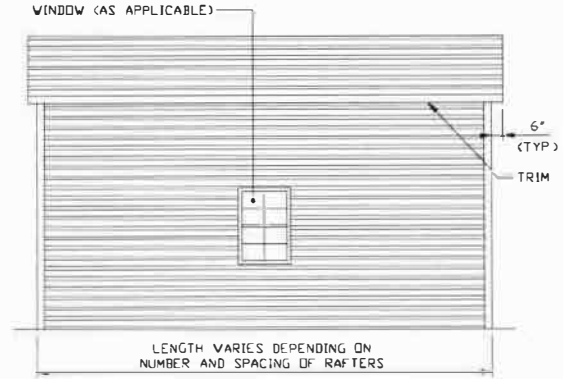

TYPICAL SIDE ELEVATION
SCALE: NTS

BOW FRAME RAFTER STRUCTURE

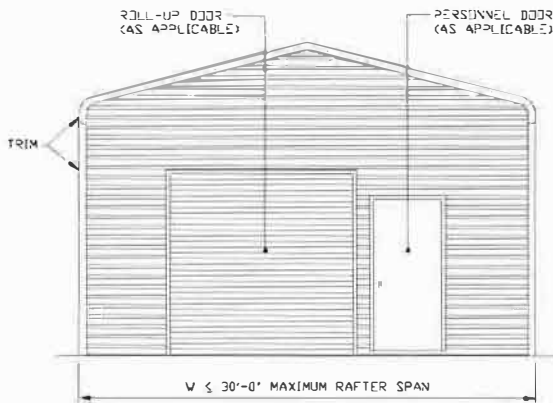

TYPICAL END ELEVATION
SCALE: NTS

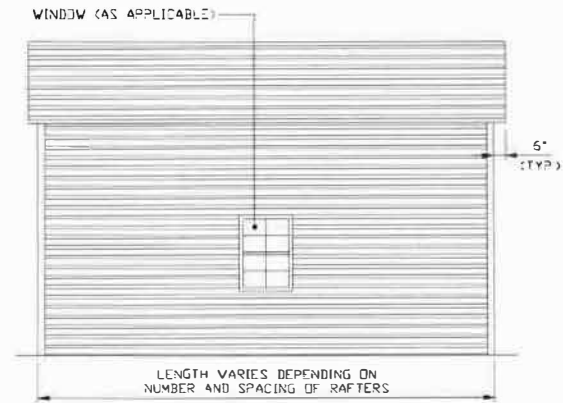

TYPICAL SIDE ELEVATION
SCALE: NTS



528 Degan Ave
Lewisville, Texas 75057

MOORE AND ASSOCIATES
ENGINEERING AND CONSULTING, INC.

DRAWN BY: AST

CHECKED BY: PDH

PROJECT MGR: WSM

30'-0" x 20'-0" ENCLOSED STRUCTURE

DATE: 11-11-19

SCALE: NTS

JOB NO: 19262S

SMT. 4

DWG. NO: SK-3

REV: 0

THIS DOCUMENT IS THE PROPERTY OF MOORE AND ASSOCIATES ENGINEERING AND CONSULTING. THE UNAUTHORIZED REPRODUCTION, COPYING, OR OTHERWISE USE OF THIS DOCUMENT IS STRICTLY PROHIBITED AND ANY INFRACTION THEREUPON MAY BE SUBJECT TO LEGAL ACTION.

EXPOSURE B

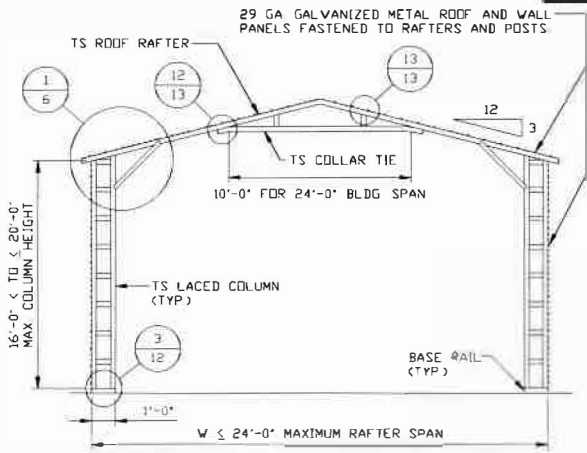

TYPICAL RAFTER/COLUMN END FRAME SECTION
SCALE: NTS

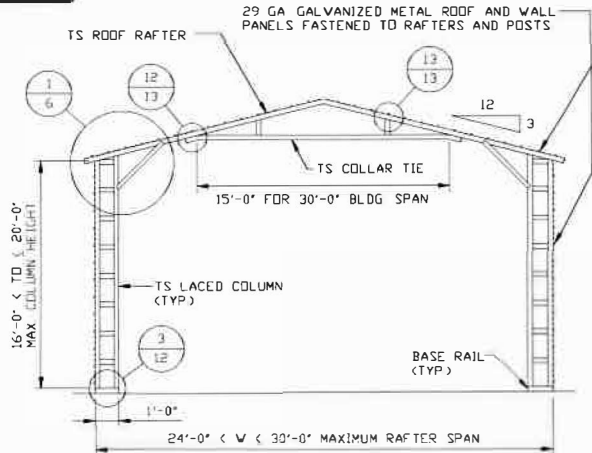

TYPICAL RAFTER/COLUMN END FRAME SECTION
SCALE: NTS

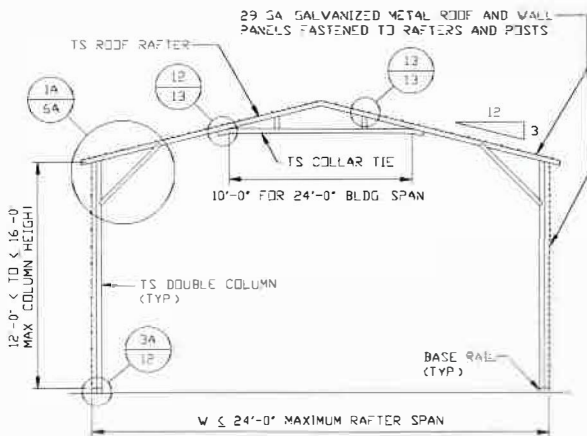

TYPICAL RAFTER/COLUMN END FRAME SECTION
SCALE: NTS

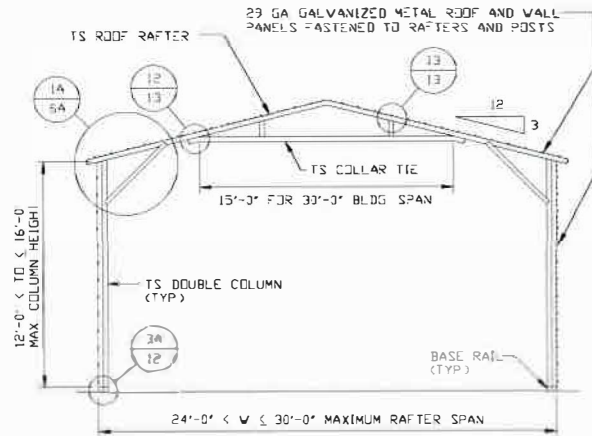

TYPICAL RAFTER/COLUMN END FRAME SECTION
SCALE: NTS

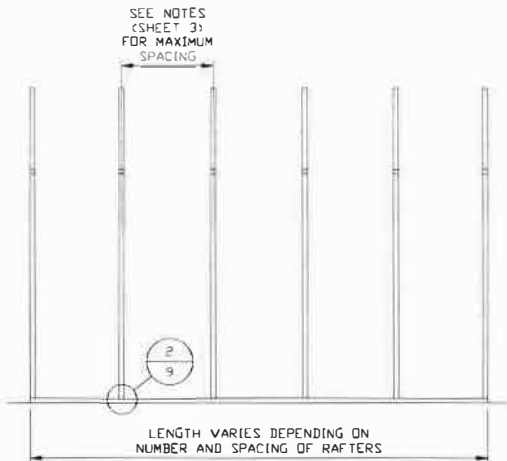

TYPICAL RAFTER/COLUMN SIDE FRAMING SECTION
SCALE: NTS



528 Degan Ave
Lewisville, Texas 75057

**MOORE AND ASSOCIATES
ENGINEERING AND CONSULTING, INC.**

DRAWN BY: AST

CHECKED BY: PDH

PROJECT MGR: WSH

30'-0"x20'-0" ENCLOSED STRUCTURE

DATE: 11-11-19

SCALE: NTS

JOB NO: 19262S

SHT. 5

DWG. NO: SK-3

REV: 0

THIS DOCUMENT IS THE PROPERTY OF MOORE AND ASSOCIATES ENGINEERING AND CONSULTING. THE UNAUTHORIZED REPRODUCTION, COPYING, OR OTHERWISE USE OF THIS DOCUMENT IS STRICTLY PROHIBITED AND ANY INFRINGEMENT THEREUPON MAY BE SUBJECT TO LEGAL ACTION.

EXPOSURE B

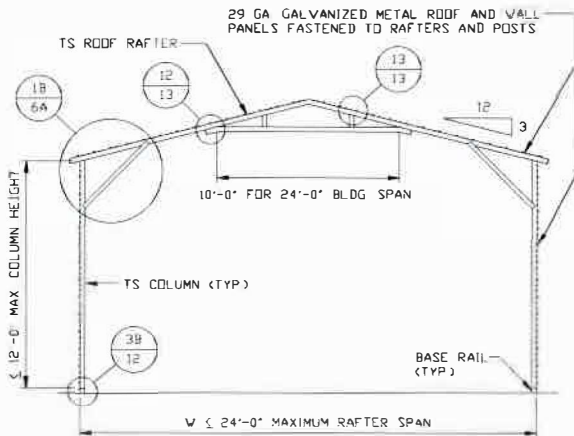

TYPICAL RAFTER/COLUMN END FRAME SECTION

SCALE: NTS

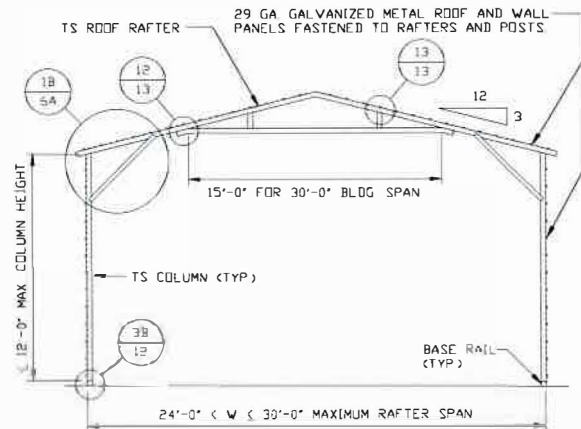

TYPICAL RAFTER/COLUMN END FRAME SECTION

SCALE: NTS

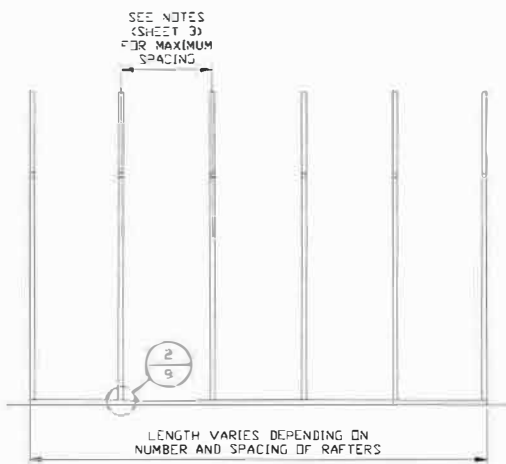

TYPICAL RAFTER/COLUMN SIDE FRAMING SECTION

SCALE: NTS



528 Degan Ave
Lewisville, Texas 75057

**MOORE AND ASSOCIATES
ENGINEERING AND CONSULTING, INC.**

DRAWN BY: AST

CHECKED BY: PDH

30'-0" x 20'-0" ENCLOSED STRUCTURE

PROJECT MGR: WSH

DATE: 11-11-19

SCALE: NTS

JOB NO: 19262S

THIS DOCUMENT IS THE PROPERTY OF MOORE AND ASSOCIATES ENGINEERING AND CONSULTING. THE UNAUTHORIZED REPRODUCTION, COPYING, OR OTHERWISE USE OF THIS DOCUMENT IS STRICTLY PROHIBITED AND ANY INFRINGEMENT THEREUPON MAY BE SUBJECT TO LEGAL ACTION.

SHT. 5A

DWG NO: SK-3

REV: 0

EXPOSURE B

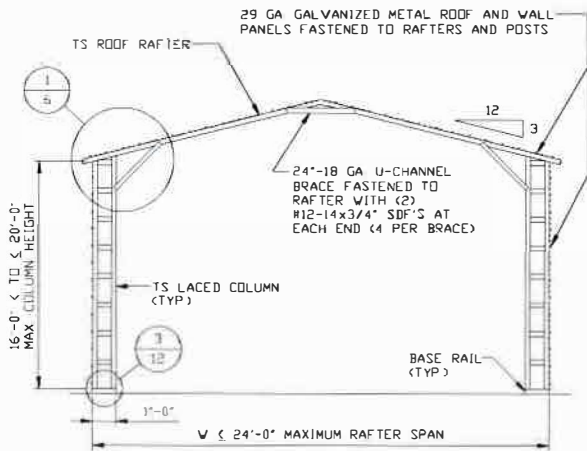

TYPICAL RAFTER/COLUMN END FRAME SECTION
SCALE: NTS

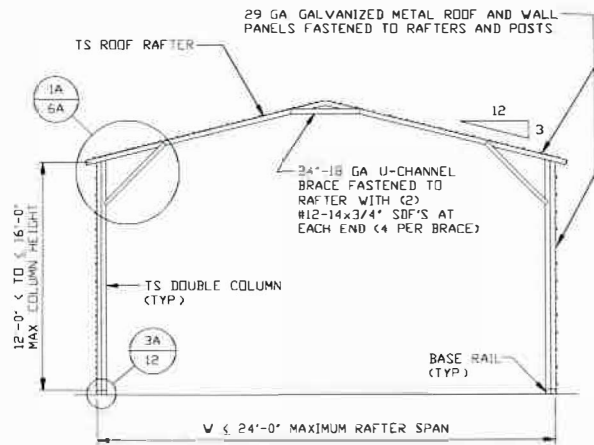

TYPICAL RAFTER/COLUMN END FRAME SECTION
SCALE: NTS

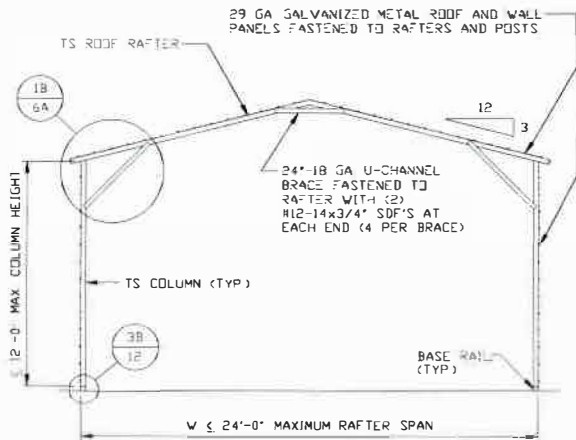

TYPICAL RAFTER/COLUMN END FRAME SECTION
SCALE: NTS

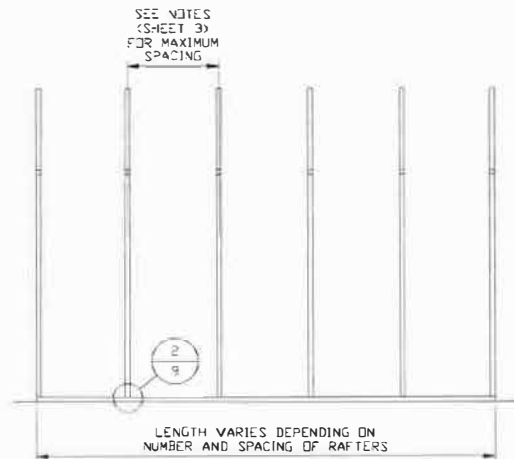

TYPICAL RAFTER/COLUMN SIDE FRAMING SECTION
SCALE: NTS



528 Degan Ave
Lewisville, Texas 75057

**MOORE AND ASSOCIATES
ENGINEERING AND CONSULTING, INC.**

DRAWN BY: AST

CHECKED BY: PDH

PROJECT MGR: WSM

30'-0"x20'-0" ENCLOSED STRUCTURE

DATE: 11-11-19

SCALE: NTS

JOB NO: 19262S

SHT. 5B

DWG. NO: SK-3

REV: 0

THIS DOCUMENT IS THE PROPERTY OF MOORE AND ASSOCIATES ENGINEERING AND CONSULTING. THE UNAUTHORIZED REPRODUCTION, COPYING, OR OTHERWISE USE OF THIS DOCUMENT IS STRICTLY PROHIBITED AND ANY INFRINGEMENT THEREUPON MAY BE SUBJECT TO LEGAL ACTION.

EXPOSURE C

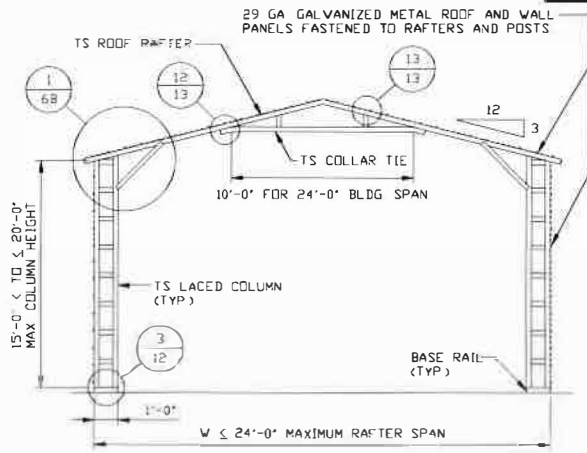

TYPICAL RAFTER/COLUMN END FRAME SECTION
SCALE: NTS

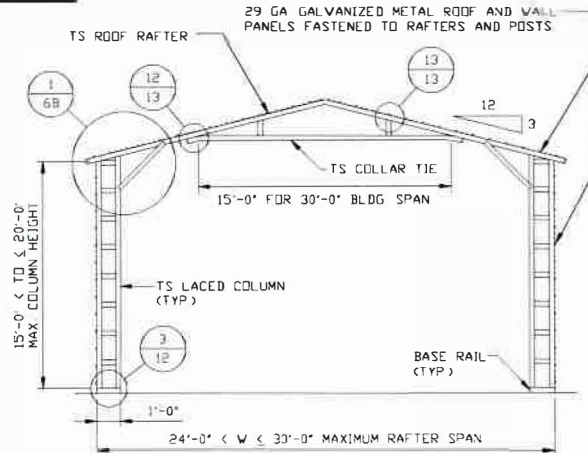

TYPICAL RAFTER/COLUMN END FRAME SECTION
SCALE: NTS

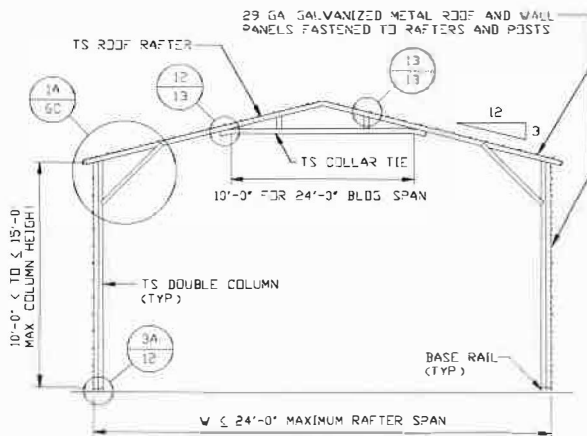

TYPICAL RAFTER/COLUMN END FRAME SECTION
SCALE: NTS

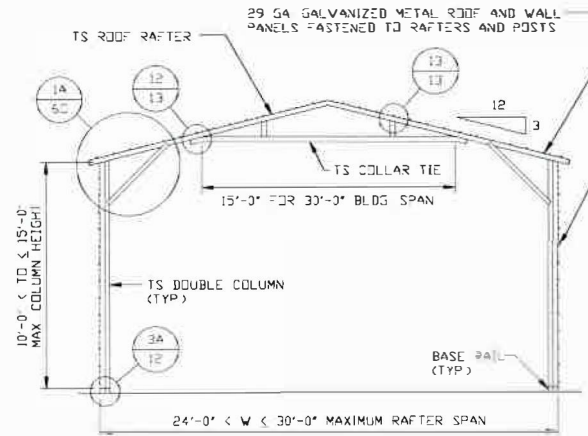

TYPICAL RAFTER/COLUMN END FRAME SECTION
SCALE: NTS

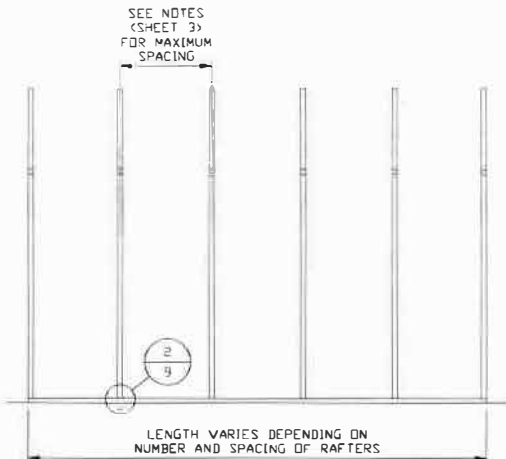

TYPICAL RAFTER/COLUMN SIDE FRAMING SECTION
SCALE: NTS



528 Degan Ave
Lewisville, Texas 75057

**MOORE AND ASSOCIATES
ENGINEERING AND CONSULTING, INC.**

DRAWN BY: AST

CHECKED BY: PDH

PROJECT MGR: VSM

DATE: 11-11-19

SHT. 5C

30'-0"x20'-0" ENCLOSED STRUCTURE

SCALE: NTS

DWG. NO: SK-3

JOB NO: 19262S

REV: 0

THIS DOCUMENT IS THE PROPERTY OF MOORE AND ASSOCIATES ENGINEERING AND CONSULTING, INC. UNAUTHORIZED REPRODUCTION, COPYING, OR OTHERWISE USE OF THIS DOCUMENT IS STRICTLY PROHIBITED AND ANY INFRINGEMENT THEREUPON MAY BE SUBJECT TO LEGAL ACTION.

EXPOSURE C

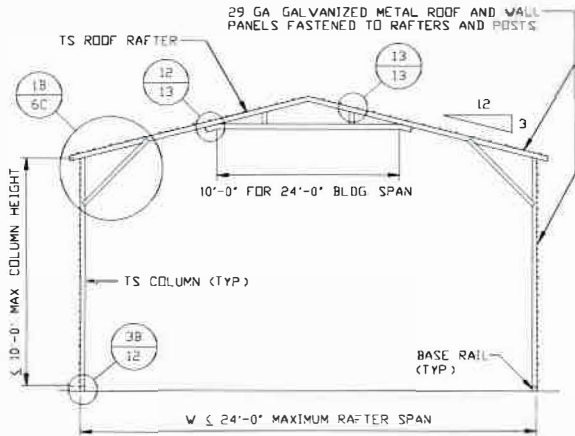

TYPICAL RAFTER/COLUMN END FRAME SECTION

SCALE: NTS

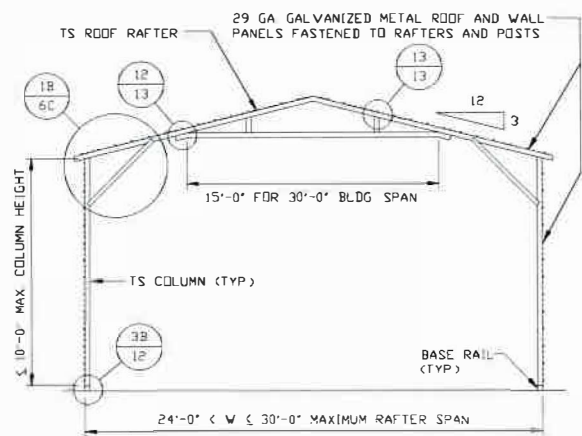

TYPICAL RAFTER/COLUMN END FRAME SECTION

SCALE: NTS

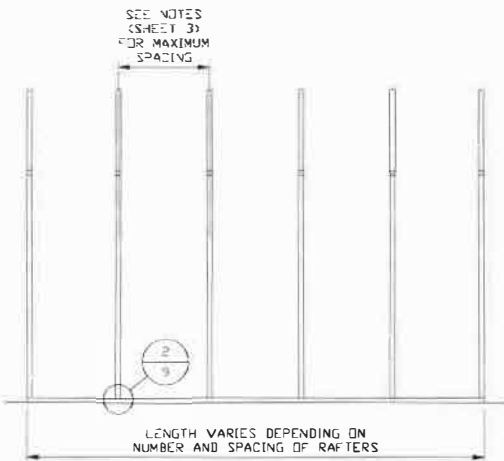

TYPICAL RAFTER/COLUMN SIDE FRAMING SECTION

SCALE: NTS



528 Degan Ave
Lewisville, Texas 75057

**MOORE AND ASSOCIATES
ENGINEERING AND CONSULTING, INC.**

DRAWN BY: AST

CHECKED BY: PDH

30'-0"x20'-0" ENCLOSED STRUCTURE

PROJECT MGR: WSM

DATE: 11-11-19

SCALE: NTS

JOB NO: 19262S

SHT. 5D

DWG. NO: SK-3

REV: 0

THIS DOCUMENT IS THE PROPERTY OF MOORE AND ASSOCIATES ENGINEERING AND CONSULTING. THE UNAUTHORIZED REPRODUCTION, COPYING, OR OTHERWISE USE OF THIS DOCUMENT IS STRICTLY PROHIBITED AND ANY INFRACTION THEREUPON MAY BE SUBJECT TO LEGAL ACTION.

EXPOSURE C

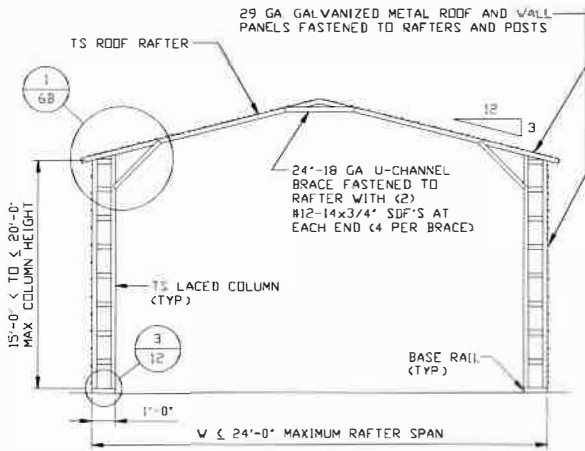

TYPICAL RAFTER/COLUMN END FRAME SECTION

SCALE: NTS

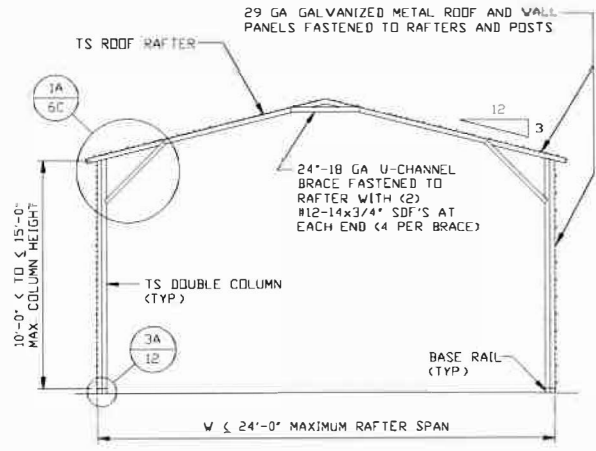

TYPICAL RAFTER/COLUMN END FRAME SECTION

SCALE: NTS

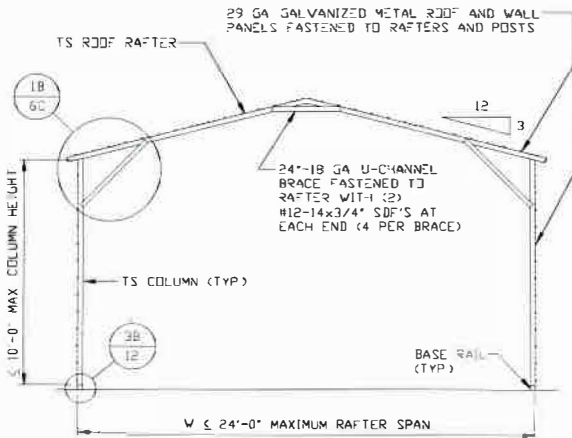

TYPICAL RAFTER/COLUMN END FRAME SECTION

SCALE: NTS

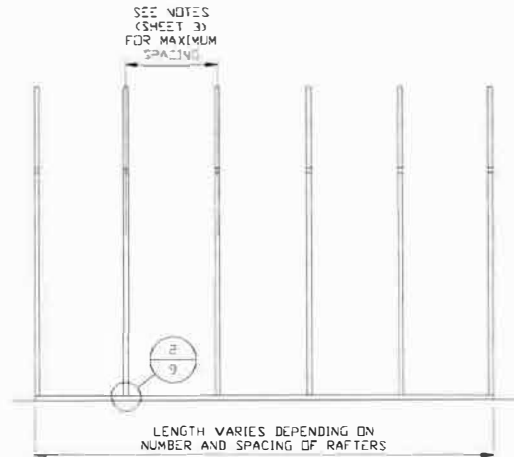

TYPICAL RAFTER/COLUMN SIDE FRAMING SECTION

SCALE: NTS



528 Degan Ave
Lewisville, Texas 75057

**MOORE AND ASSOCIATES
ENGINEERING AND CONSULTING, INC.**

DRAWN BY: AST

CHECKED BY: PDH

PROJECT MGR: VSM

DATE: 11-11-19

SHT. 5E

30'-0"X20'-0" ENCLOSED STRUCTURE

SCALE: NTS

DWG. NO: SK-3

JOB NO: 19262S

REV: 0

THIS DOCUMENT IS THE PROPERTY OF MOORE AND ASSOCIATES ENGINEERING AND CONSULTING, INC. UNAUTHORIZED REPRODUCTION, COPYING, OR OTHERWISE USE OF THIS DOCUMENT IS STRICTLY PROHIBITED AND ANY INFRACTION THEREUPON MAY BE SUBJECT TO LEGAL ACTION.

EXPOSURE B

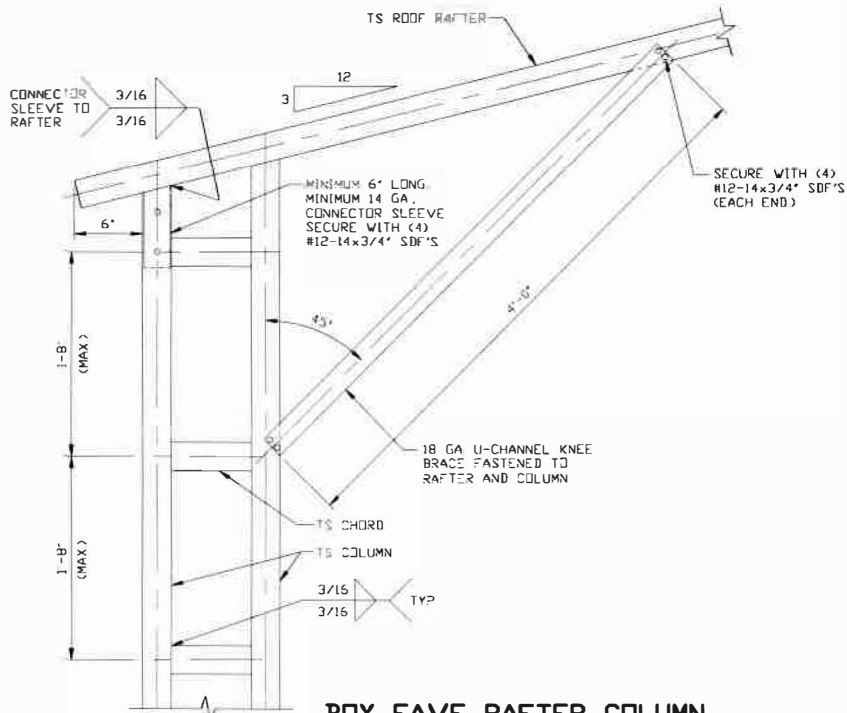

1
BOX EAVE RAFTER COLUMN CONNECTION DETAIL FOR HEIGHTS 16'-0" < TO ≤ 20'-0"
 SCALE: NTS

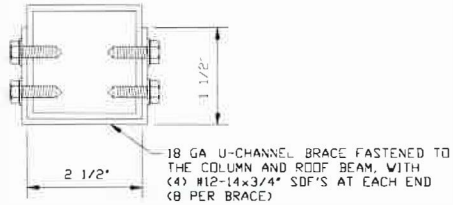

BRACE SECTION
 SCALE: NTS



528 Degan Ave
 Lewisville, Texas 75057

MOORE AND ASSOCIATES
 ENGINEERING AND CONSULTING, INC.

DRAWN BY: AST

CHECKED BY: PDH

30'-0"x20'-0" ENCLOSED STRUCTURE

PROJECT MGR: WSM

DATE: 11-11-19

SCALE: NTS

JOB NO: 19262S

THIS DOCUMENT IS THE PROPERTY OF MOORE AND ASSOCIATES ENGINEERING AND CONSULTING. THE UNAUTHORIZED REPRODUCTION, COPYING, OR OTHERWISE USE OF THIS DOCUMENT IS STRICTLY PROHIBITED AND ANY OFFENSEMENT THEREUPON MAY BE SUBJECT TO LEGAL ACTION.

SHT. 6

DWG. NO: SK-3

REV: 0

EXPOSURE B

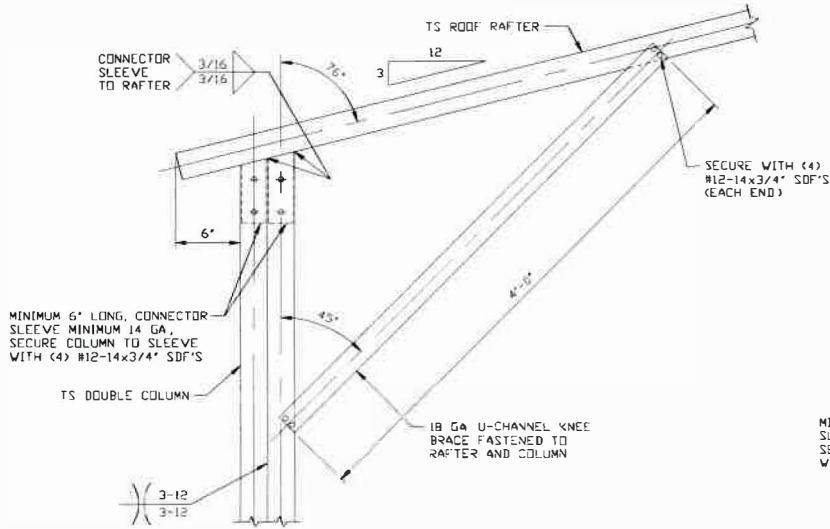

BOX EAVE RAFTER COLUMN CONNECTION DETAIL FOR HEIGHTS 12'-0" < TO <= 16'-0"

1A

SCALE: NTS

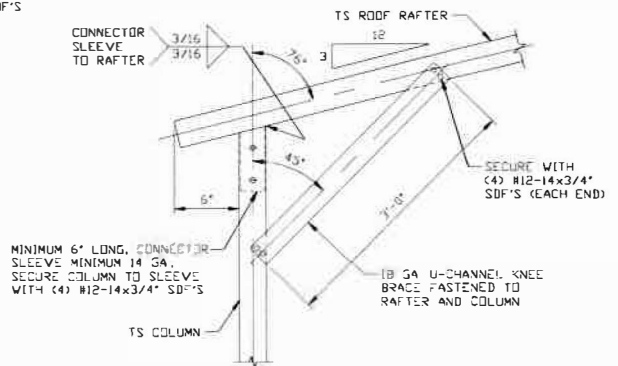

BOX EAVE RAFTER COLUMN CONNECTION DETAIL FOR HEIGHTS <= 12'-0"

1B

SCALE: NTS

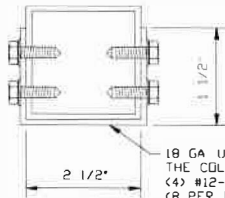

BRACE SECTION

SCALE: NTS



528 Degan Ave
Lewisville, Texas 75057

**MOORE AND ASSOCIATES
ENGINEERING AND CONSULTING, INC.**

DRAWN BY: AST

CHECKED BY: PDH

PROJECT MGR: VSM

30'-0"x20'-0" ENCLOSED STRUCTURE

DATE: 11-11-19

SHT. 6A

SCALE: NTS

DWG. NO: SK-3

JOB NO: 19262S

REV: 0

THIS DOCUMENT IS THE PROPERTY OF MOORE AND ASSOCIATES ENGINEERING AND CONSULTING. THE UNAUTHORIZED REPRODUCTION, COPYING, OR OTHERWISE USE OF THIS DOCUMENT IS STRICTLY PROHIBITED AND ANY INFRINGEMENT THEREUPON MAY BE SUBJECT TO LEGAL ACTION.

EXPOSURE C

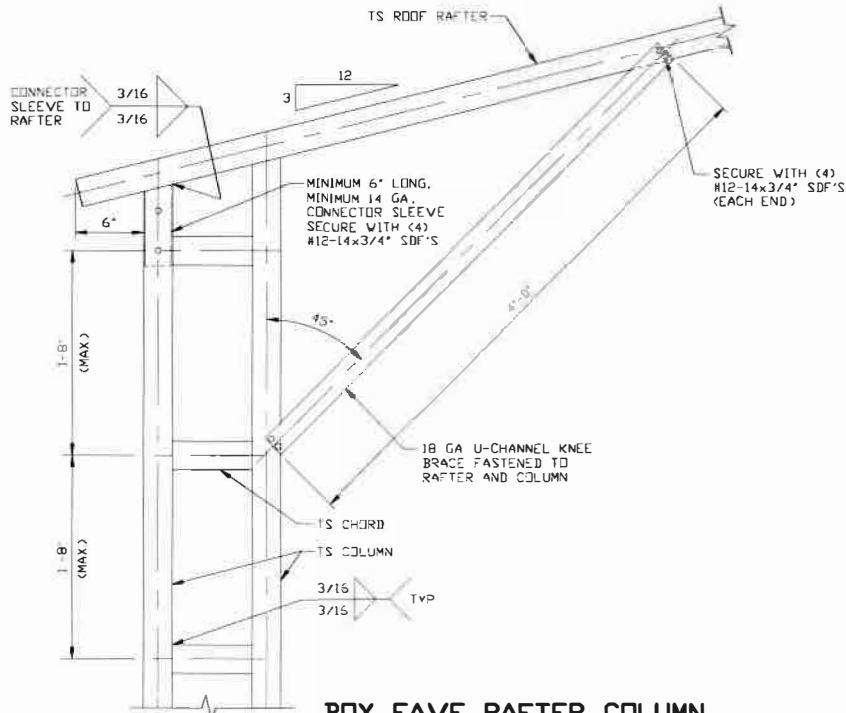

1 BOX EAVE RAFTER COLUMN CONNECTION DETAIL FOR HEIGHTS 15'-0" < TO ≤ 20'-0"
SCALE: NTS

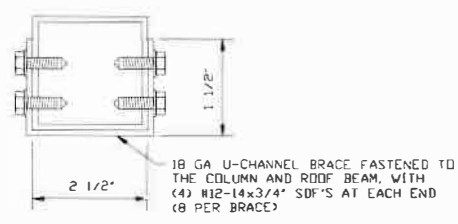

BRACE SECTION
SCALE: NTS



528 Degan Ave
Lewisville, Texas 75057

MOORE AND ASSOCIATES ENGINEERING AND CONSULTING, INC.	DRAWN BY: AST	30'-0"x20'-0" ENCLOSED STRUCTURE		
	CHECKED BY: PDH			
THIS DOCUMENT IS THE PROPERTY OF MOORE AND ASSOCIATES ENGINEERING AND CONSULTING. THE UNAUTHORIZED REPRODUCTION, COPYING, OR OTHERWISE USE OF THIS DOCUMENT IS STRICTLY PROHIBITED AND ANY INFREMENT THEREUPON MAY BE SUBJECT TO LEGAL ACTION.	PROJECT MGR: VSM	DATE: 11-11-19	SCALE: NTS	JOB NO: 19262S
		SHT. 6B	DWG. NO: SK-3	REV: 0

EXPOSURE C

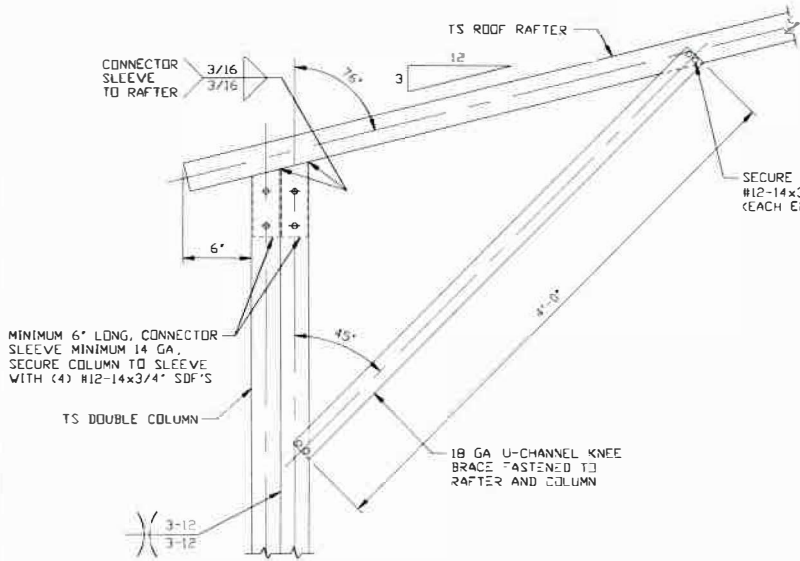

1A BOX EAVE RAFTER COLUMN CONNECTION DETAIL FOR HEIGHTS 10'-0" < TO <= 15'-0" SCALE: NTS

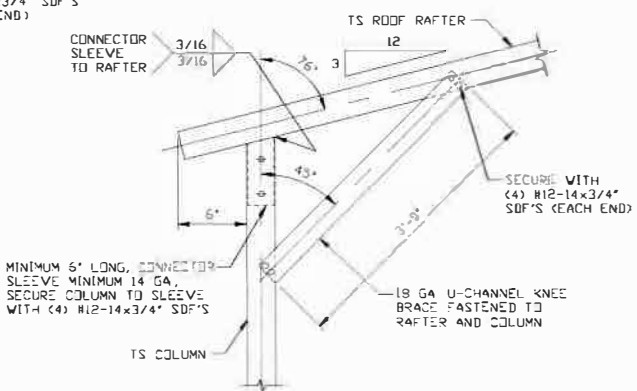

1B BOX EAVE RAFTER COLUMN CONNECTION DETAIL FOR HEIGHTS <= 10'-0" SCALE: NTS

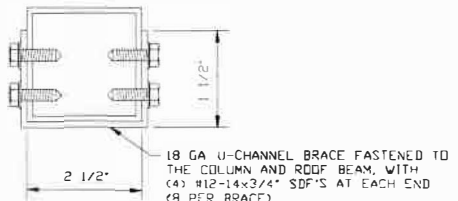

BRACE SECTION
SCALE: NTS



528 Degan Ave
Lewisville, Texas 75057

MOORE AND ASSOCIATES ENGINEERING AND CONSULTING, INC.	DRAWN BY: AST	30'-0"x20'-0" ENCLOSED STRUCTURE		
	CHECKED BY: PDH			
THIS DOCUMENT IS THE PROPERTY OF MOORE AND ASSOCIATES ENGINEERING AND CONSULTING, THE UNAUTHORIZED REPRODUCTION, COPYING, OR OTHERWISE USE OF THIS DOCUMENT IS STRICTLY PROHIBITED AND ANY VIOLATION THEREOF MAY BE SUBJECT TO LEGAL ACTION.	PROJECT MGR: VSM	DATE: 11-11-19	SCALE: NTS	JOB NO: 19262S
		SHT. 6C	DWG. NO: SK-3	REV: 0

EXPOSURE B

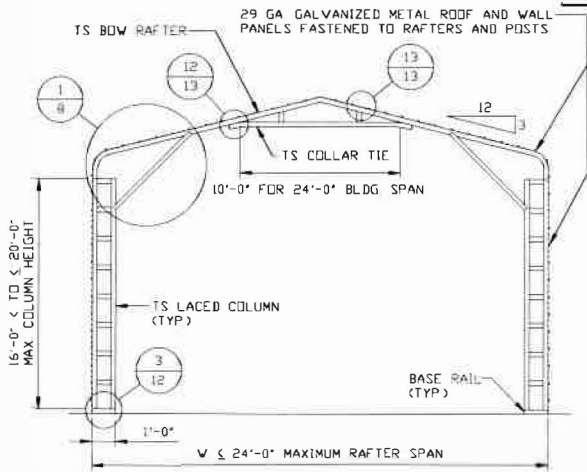

TYPICAL RAFTER/COLUMN END FRAME SECTION
SCALE: NTS

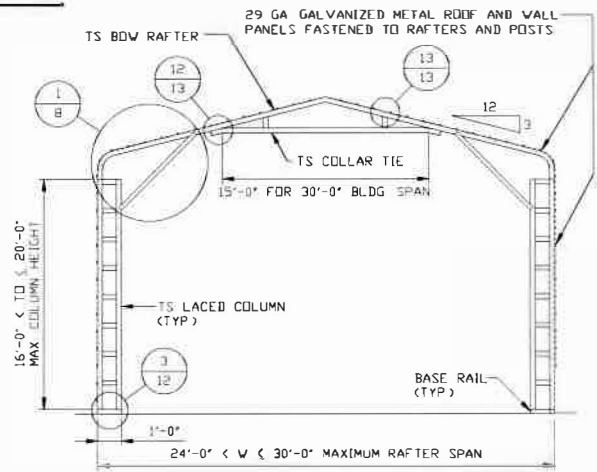

TYPICAL RAFTER/COLUMN END FRAME SECTION
SCALE: NTS

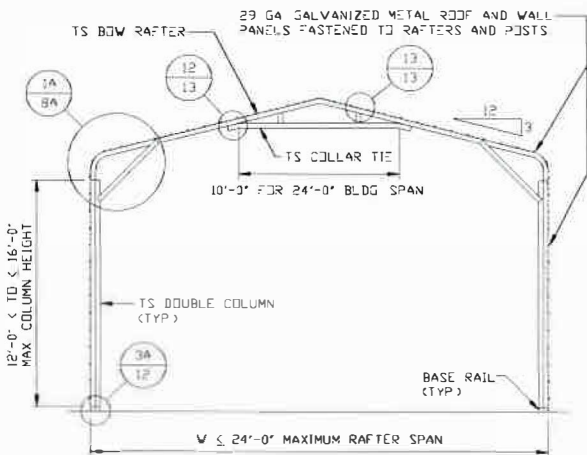

TYPICAL RAFTER/COLUMN END FRAME SECTION
SCALE: NTS

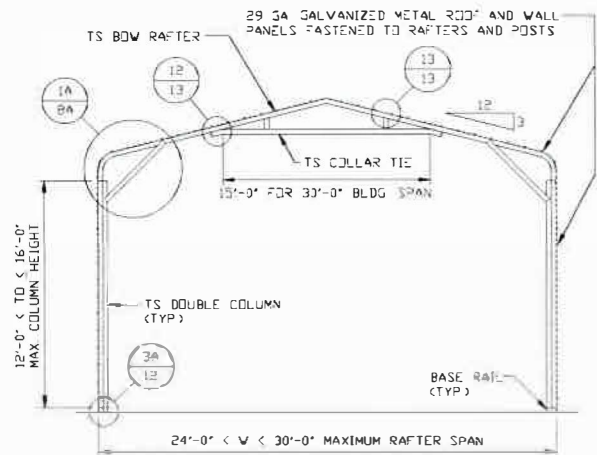

TYPICAL RAFTER/COLUMN END FRAME SECTION
SCALE: NTS

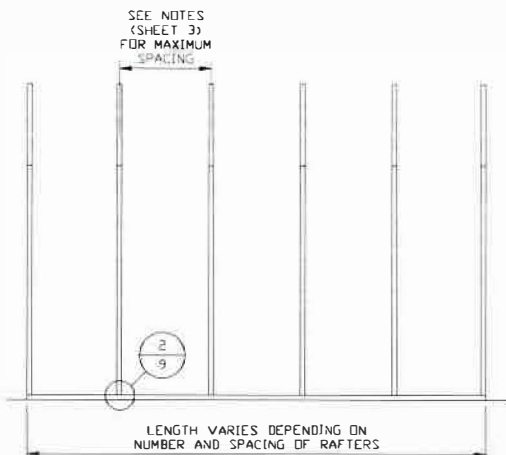

TYPICAL RAFTER/COLUMN FRAMING SIDE SECTION
SCALE: NTS



528 Degan Ave
Lewisville, Texas 75057

**MOORE AND ASSOCIATES
ENGINEERING AND CONSULTING, INC.**

DRAWN BY: AST

CHECKED BY: PDH

30'-0" x 20'-0" ENCLOSED STRUCTURE

PROJECT MGR: WSH

DATE: 11-11-19

SCALE: NTS

JOB NO: 19262S

SHT. 7

DWG. NO: SK-3

REV: 0

THIS DOCUMENT IS THE PROPERTY OF MOORE AND ASSOCIATES ENGINEERING AND CONSULTING. THE UNAUTHORIZED REPRODUCTION, COPYING, OR OTHERWISE USE OF THIS DOCUMENT IS STRICTLY PROHIBITED AND ANY INFRACTION THEREUPON MAY BE SUBJECT TO LEGAL ACTION.

EXPOSURE B

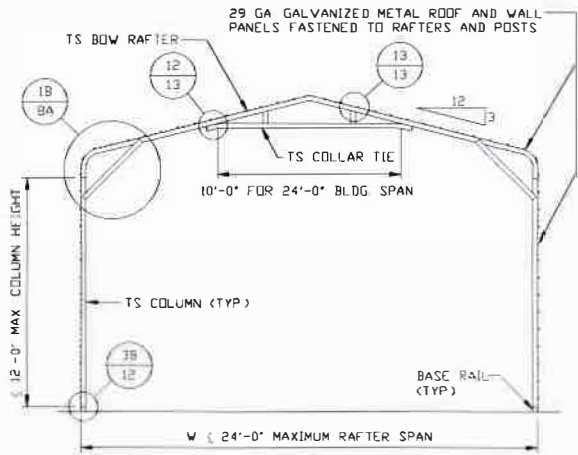

TYPICAL RAFTER/COLUMN END FRAME SECTION
SCALE: NTS

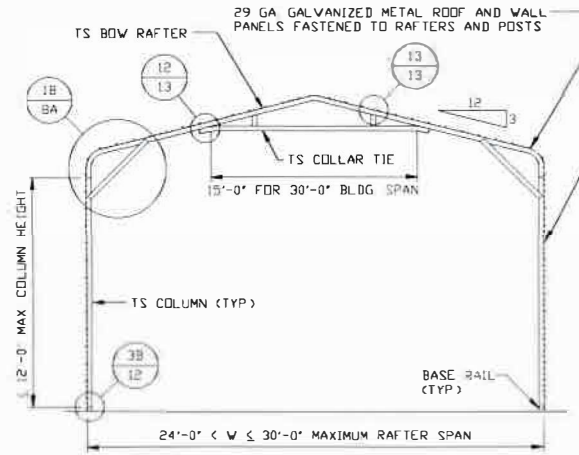

TYPICAL RAFTER/COLUMN END FRAME SECTION
SCALE: NTS

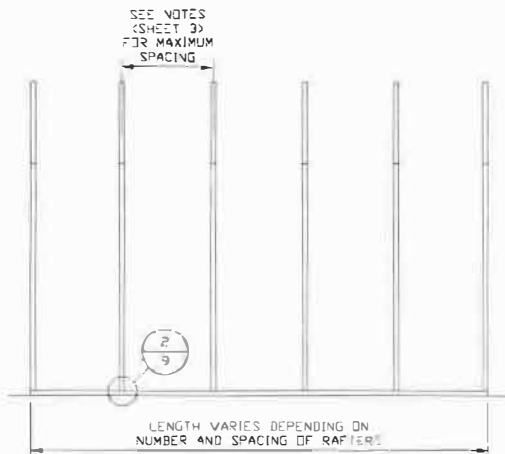

TYPICAL RAFTER/COLUMN FRAMING SIDE SECTION
SCALE: NTS



528 Degan Ave
Lewisville, Texas 75057

**MOORE AND ASSOCIATES
ENGINEERING AND CONSULTING, INC.**

DRAWN BY: AST

CHECKED BY: PDH

30'-0"x20'-0" ENCLOSED STRUCTURE

PROJECT MGR: WSM

DATE: 11-11-19

SCALE: NTS

JOB NO: 19262S

THIS DOCUMENT IS THE PROPERTY OF MOORE AND ASSOCIATES ENGINEERING AND CONSULTING. THE UNAUTHORIZED REPRODUCTION, COPYING, OR OTHERWISE USE OF THIS DOCUMENT IS STRICTLY PROHIBITED AND ANY INFRINGEMENT THEREUPON MAY BE SUBJECT TO LEGAL ACTION.

SHT. 7A

DWG. NO: SK-3

REV: 0

EXPOSURE B

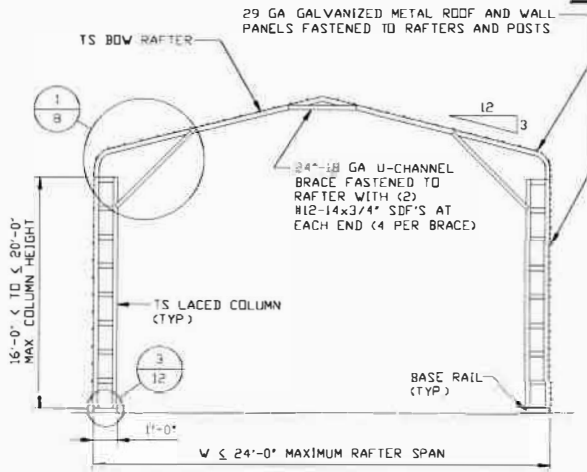

TYPICAL RAFTER/COLUMN END FRAME SECTION
SCALE: NTS

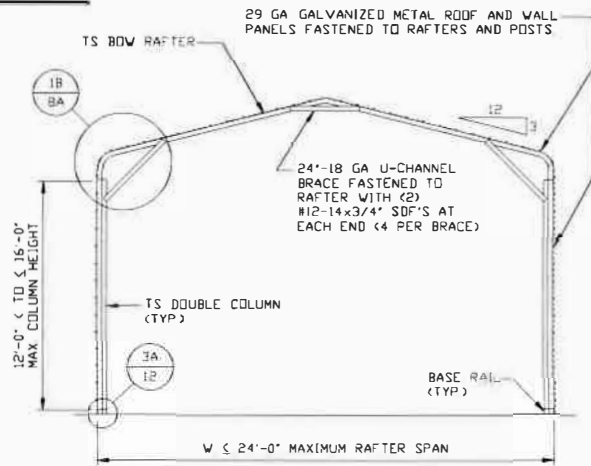

TYPICAL RAFTER/COLUMN END FRAME SECTION
SCALE: NTS

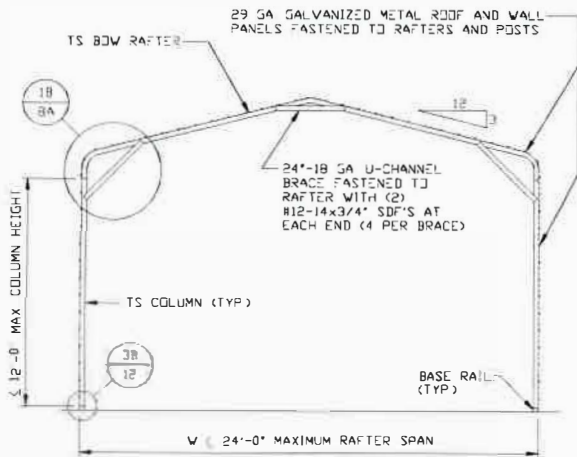

TYPICAL RAFTER/COLUMN END FRAME SECTION
SCALE: NTS

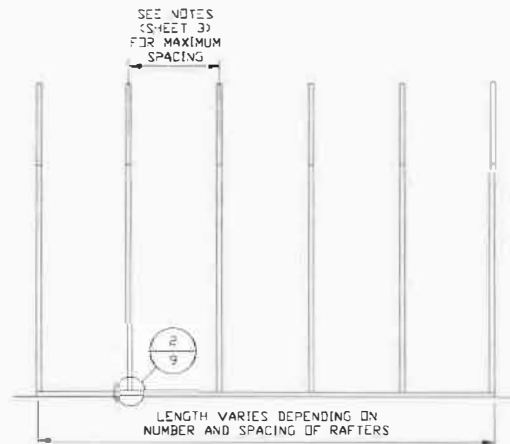

TYPICAL RAFTER/COLUMN FRAMING SIDE SECTION
SCALE: NTS



528 Degan Ave
Lewisville, Texas 75057

MOORE AND ASSOCIATES
ENGINEERING AND CONSULTING, INC.

DRAWN BY: AST

CHECKED BY: PDM

30'-0"x20'-0" ENCLOSED STRUCTURE

PROJECT MGR: WSM

DATE: 11-11-19

SCALE: NTS

JOB NO: 192625

THIS DOCUMENT IS THE PROPERTY OF MOORE AND ASSOCIATES ENGINEERING AND CONSULTING. THE UNAUTHORIZED REPRODUCTION, COPYING, OR OTHERWISE USE OF THIS DOCUMENT IS STRICTLY PROHIBITED AND ANY INFRINGEMENT THEREUPON MAY BE SUBJECT TO LEGAL ACTION.

SHT. 7B

DWG. NO: SK-3

REV: 0

EXPOSURE C

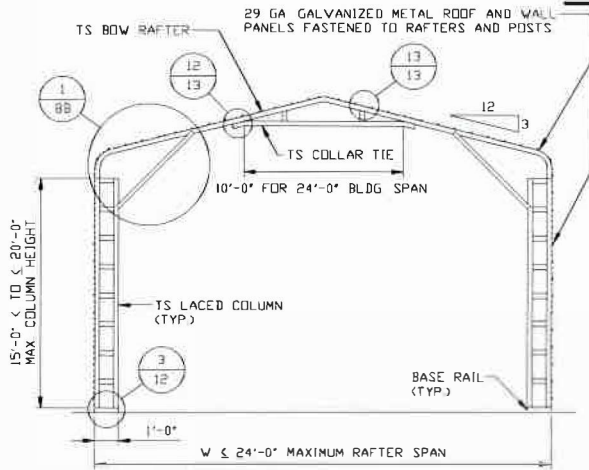

TYPICAL RAFTER/COLUMN END FRAME SECTION
SCALE: NTS

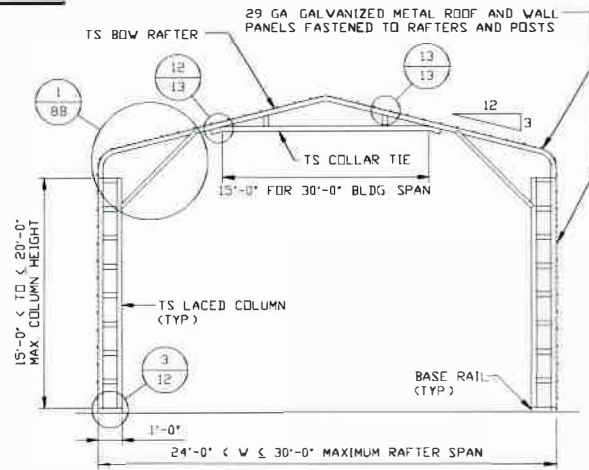

TYPICAL RAFTER/COLUMN END FRAME SECTION
SCALE: NTS

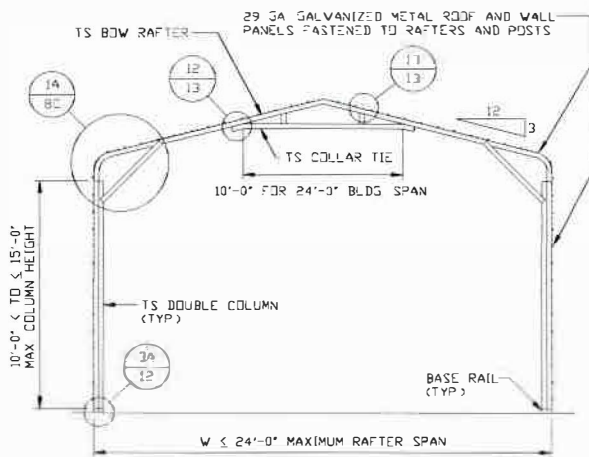

TYPICAL RAFTER/COLUMN END FRAME SECTION
SCALE: NTS

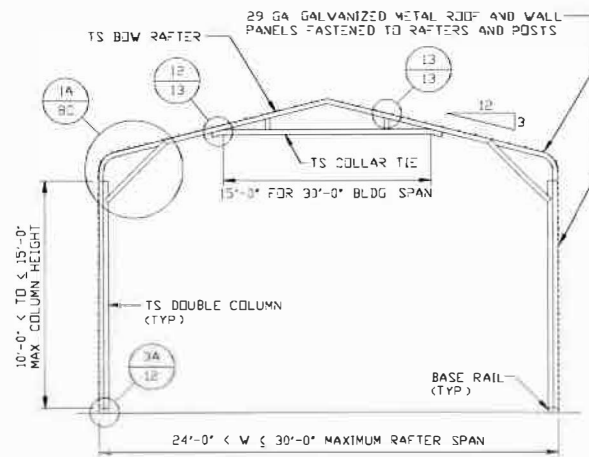

TYPICAL RAFTER/COLUMN END FRAME SECTION
SCALE: NTS

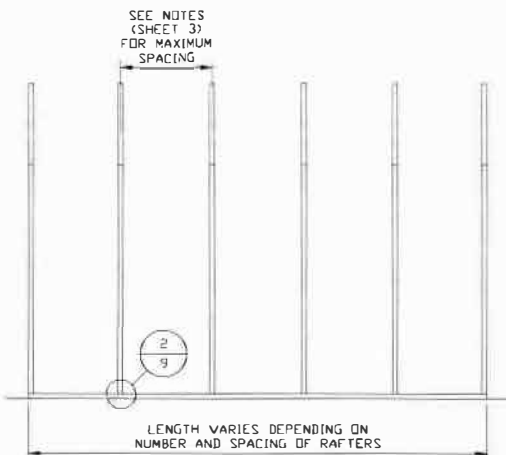

TYPICAL RAFTER/COLUMN FRAMING SIDE SECTION
SCALE: NTS



528 Degan Ave
Lewisville, Texas 75057

**MOORE AND ASSOCIATES
ENGINEERING AND CONSULTING, INC.**

DRAWN BY: AST

CHECKED BY: PDH

PROJECT MGR: VSM

3'0"-0"x0'-0" ENCLOSED STRUCTURE

DATE: 11-11-19

SCALE: NTS

JOB NO: 19262S

SHT. 7C

DWG. NO: SK-3

REV: 0

THIS DOCUMENT IS THE PROPERTY OF MOORE AND ASSOCIATES ENGINEERING AND CONSULTING, INC. THE UNAUTHORIZED REPRODUCTION, COPYING, OR OTHERWISE USE OF THIS DOCUMENT IS STRICTLY PROHIBITED AND ANY INFRINGEMENT THEREUPON MAY BE SUBJECT TO LEGAL ACTION.

EXPOSURE C

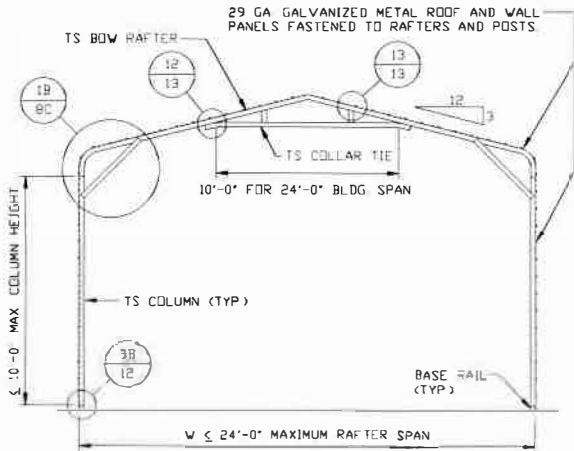

TYPICAL RAFTER/COLUMN END FRAME SECTION
SCALE: NTS

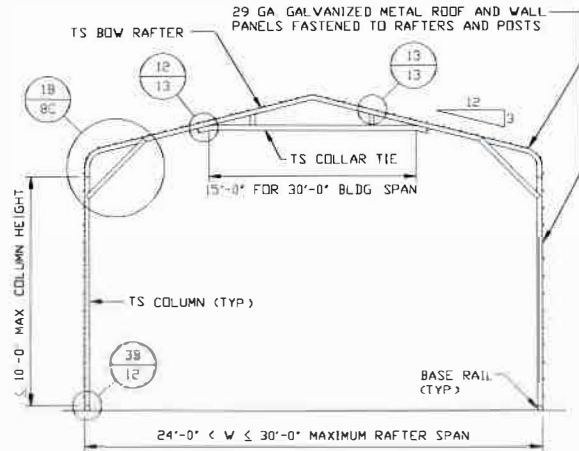

TYPICAL RAFTER/COLUMN END FRAME SECTION
SCALE: NTS

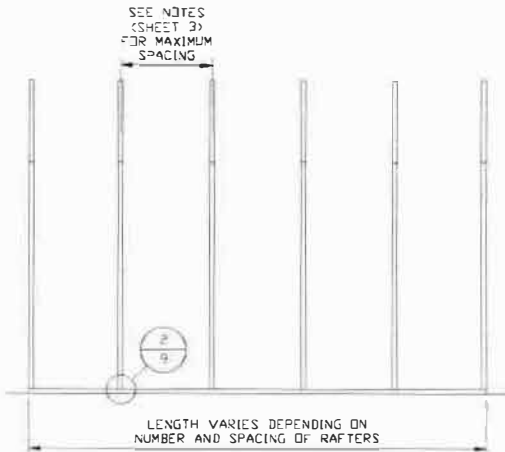

TYPICAL RAFTER/COLUMN FRAMING SIDE SECTION
SCALE: NTS



528 Degan Ave
Lewisville, Texas 75057

**MOORE AND ASSOCIATES
ENGINEERING AND CONSULTING, INC.**

DRAWN BY: AST

CHECKED BY: PDH

PROJECT MGR: WSM

30'-0"x20'-0" ENCLOSED STRUCTURE

DATE: 11-11-19

SCALE: NTS

JOB NO: 19262S

SHT. 7D

DWG. NO: SK-3

REV: 0

THIS DOCUMENT IS THE PROPERTY OF MOORE AND ASSOCIATES ENGINEERING AND CONSULTING, INC. UNAUTHORIZED REPRODUCTION, COPYING, OR OTHERWISE USE OF THIS DOCUMENT IS STRICTLY PROHIBITED AND ANY INFRINGEMENT THEREUPON MAY BE SUBJECT TO LEGAL ACTION.

EXPOSURE C

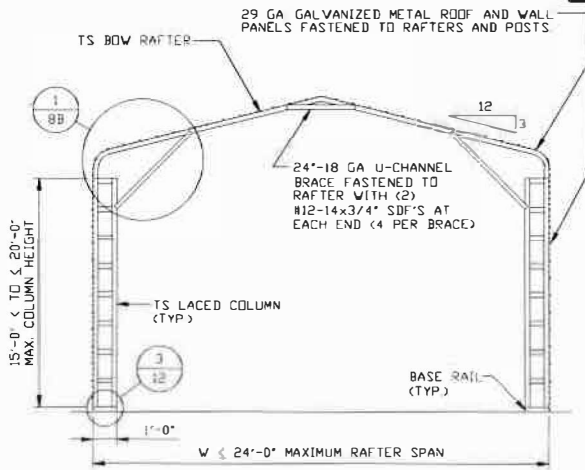

TYPICAL RAFTER/COLUMN END FRAME SECTION

SCALE: NTS

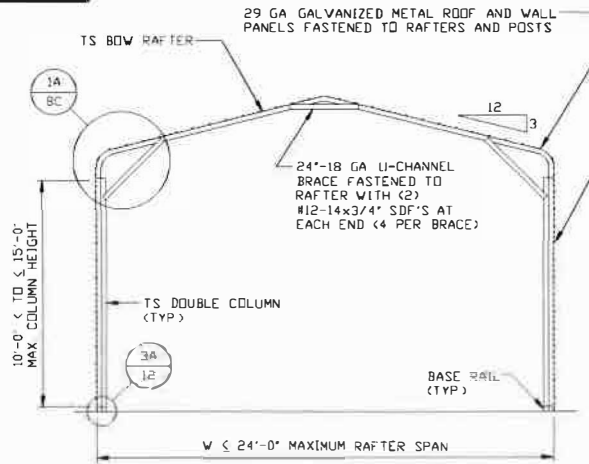

TYPICAL RAFTER/COLUMN END FRAME SECTION

SCALE: NTS

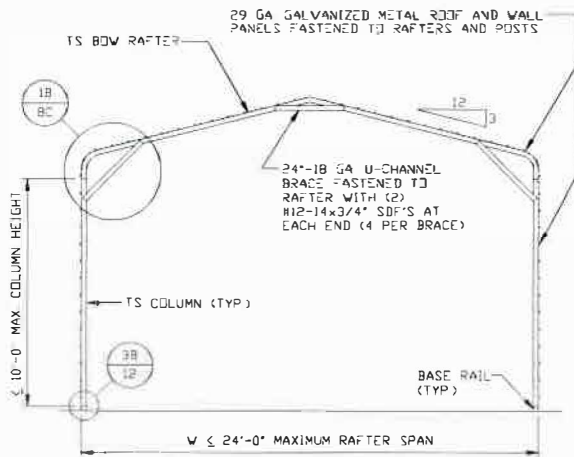

TYPICAL RAFTER/COLUMN END FRAME SECTION

SCALE: NTS

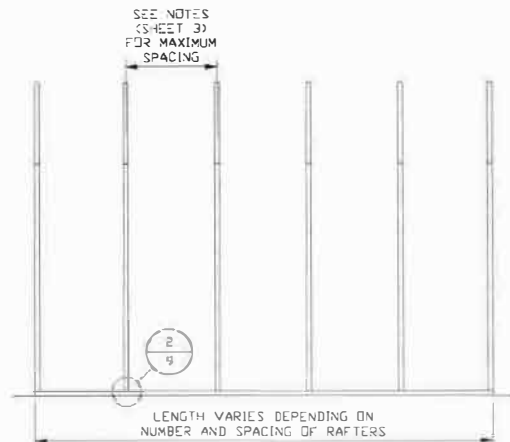

TYPICAL RAFTER/COLUMN FRAMING SIDE SECTION

SCALE: NTS



528 Degan Ave
Lewisville, Texas 75057

**MOORE AND ASSOCIATES
ENGINEERING AND CONSULTING, INC.**

DRAWN BY: AST

CHECKED BY: PDH

PROJECT MGR: WSM

30'-0"x20'-0" ENCLOSED STRUCTURE

DATE: 11-11-19

SCALE: NTS

JOB NO: 19262S

SHT. 7E

DWG. NO: SK-3

REV: 0

THIS DOCUMENT IS THE PROPERTY OF MOORE AND ASSOCIATES ENGINEERING AND CONSULTING. THE UNAUTHORIZED REPRODUCTION, COPYING, OR OTHERWISE USE OF THIS DOCUMENT IS STRICTLY PROHIBITED AND ANY INFRINGEMENT THEREUPON MAY BE SUBJECT TO LEGAL ACTION.

EXPOSURE B

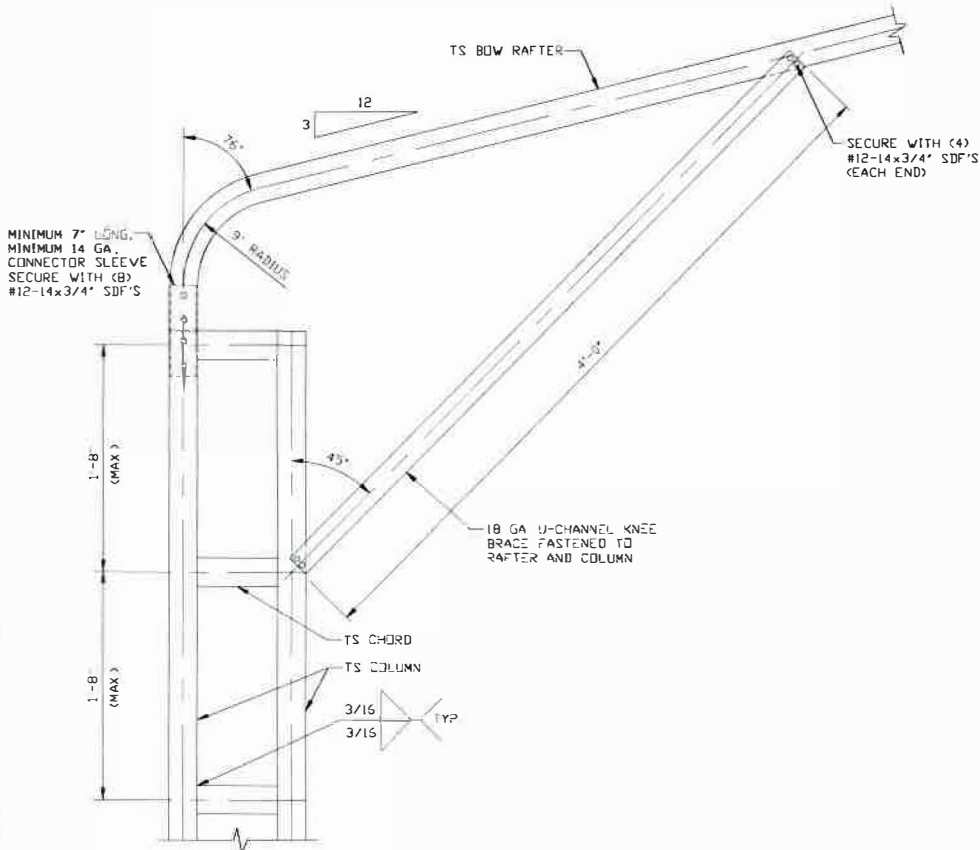

1 BOW EAVE RAFTER COLUMN CONNECTION
 DETAIL FOR HEIGHTS 16'-0" < TO ≤ 20'-0"
 SCALE: NTS

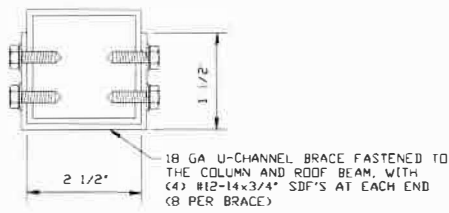

BRACE SECTION
 SCALE: NTS



528 Degan Ave
 Lewisville, Texas 75057

MOORE AND ASSOCIATES ENGINEERING AND CONSULTING, INC.	DRAWN BY: AST	30'-0"x20'-0" ENCLOSED STRUCTURE		
	CHECKED: <u> </u> PDH			
THIS DOCUMENT IS THE PROPERTY OF MOORE AND ASSOCIATES ENGINEERING AND CONSULTING. THE UNAUTHORIZED REPRODUCTION, COPYING, OR OTHERWISE USE OF THIS DOCUMENT IS STRICTLY PROHIBITED AND ANY INFRACTION THEREUPON MAY BE SUBJECT TO LEGAL ACTION.	PROJECT MGR: WSH	DATE: 11-11-19	SCALE: NTS	JOB NO: 19262S
		SHT. 8	DWG. NO: SK-3	REV: 0

EXPOSURE B

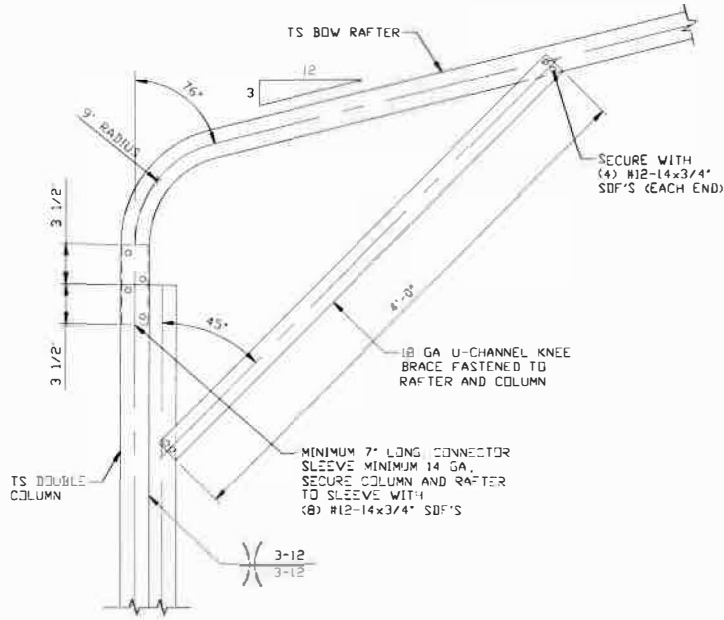

1A BOW EAVE RAFTER COLUMN CONNECTION DETAIL FOR HEIGHTS 12'-0" < TO <= 16'-0" SCALE: NTS

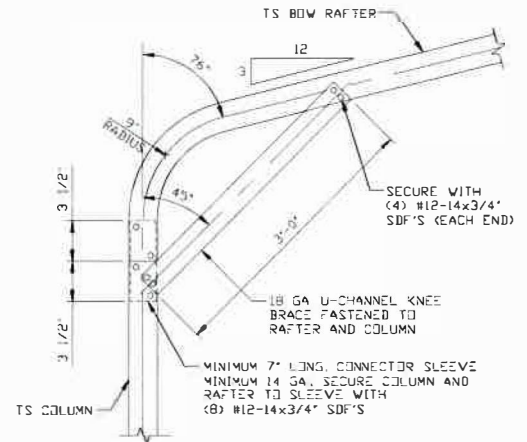

1B BOW EAVE RAFTER COLUMN CONNECTION DETAIL FOR HEIGHTS <= 12'-0" SCALE: NTS

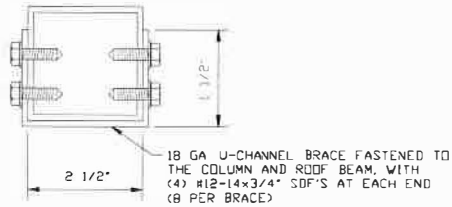

BRACE SECTION SCALE: NTS



528 Degan Ave
Lewisville, Texas 75057

MOORE AND ASSOCIATES
ENGINEERING AND CONSULTING, INC.

DRAWN BY: AST

CHECKED BY: PDH

30'-0" x 20'-0" ENCLOSED STRUCTURE

PROJECT MGR: VSM

DATE: 11-11-19

SCALE: NTS

JOB NO: 19262S

SHT. 8A

DWG. NO: SK-3

REV: 0

THIS DOCUMENT IS THE PROPERTY OF MOORE AND ASSOCIATES ENGINEERING AND CONSULTING, INC. UNAUTHORIZED REPRODUCTION, COPYING, OR OTHERWISE USE OF THIS DOCUMENT IS STRICTLY PROHIBITED AND ANY INFRACTION THEREUPON MAY BE SUBJECT TO LEGAL ACTION.

EXPOSURE C

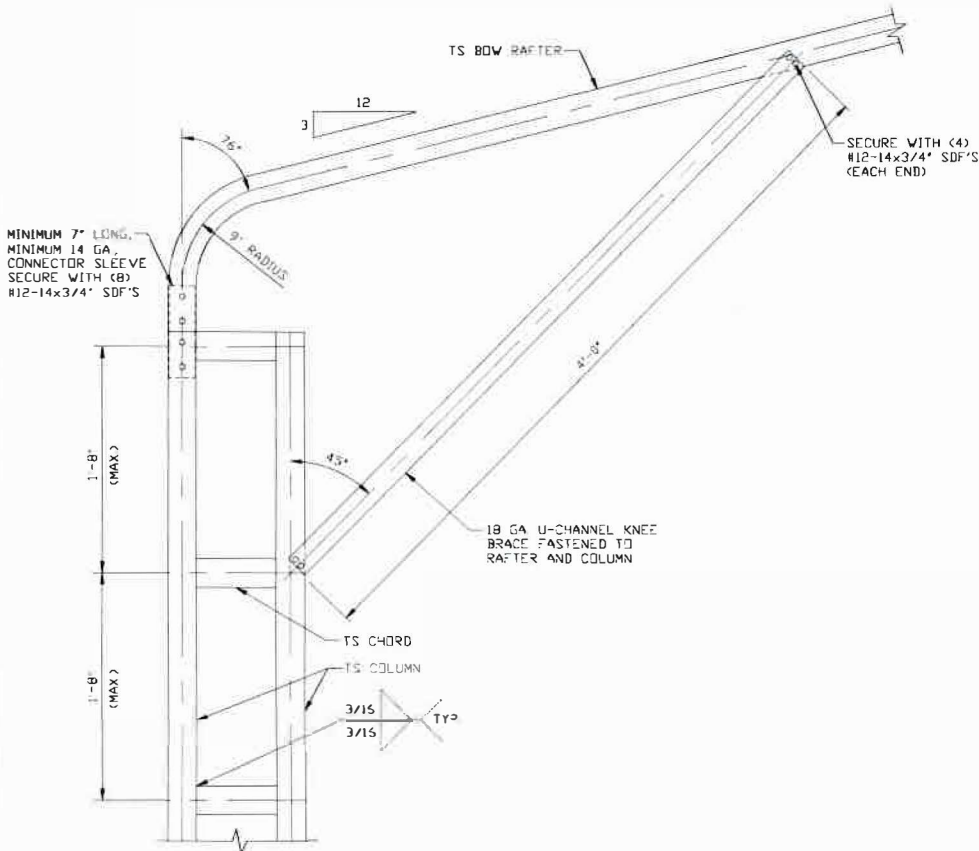

1 **BOW EAVE RAFTER COLUMN CONNECTION**
DETAIL FOR HEIGHTS 15'-0" < TO ≤ 20'-0"
 SCALE NTS

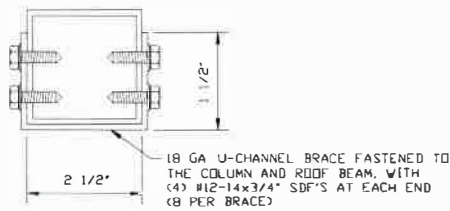

BRACE SECTION
 SCALE NTS



528 Degan Ave
 Lewisville, Texas 75057

MOORE AND ASSOCIATES
ENGINEERING AND CONSULTING, INC.

DRAWN BY: AST

CHECKED: BPDH

30'-0"x20'-0" ENCLOSED STRUCTURE

PROJECT MGR: WSM

DATE: 11-11-19

SCALE: NTS

JOB NO: 19262S

SHT. 08

DWG. NO: SK-3

REV: 0

THIS DOCUMENT IS THE PROPERTY OF MOORE AND ASSOCIATES ENGINEERING AND CONSULTING. THE UNAUTHORIZED REPRODUCTION, COPYING, OR OTHERWISE USE OF THIS DOCUMENT IS STRICTLY PROHIBITED AND ANY INFRINGEMENT THEREUPON MAY BE SUBJECT TO LEGAL ACTION.

EXPOSURE C

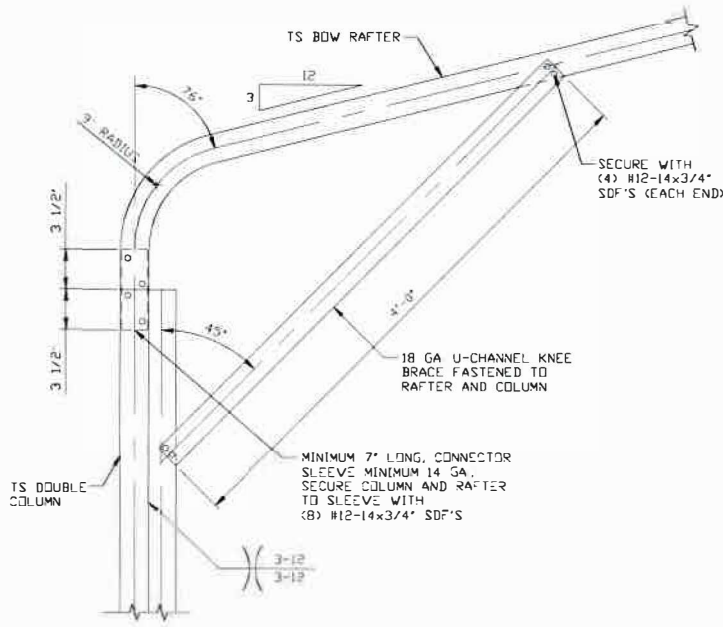

1A
BOW EAVE RAFTER COLUMN CONNECTION DETAIL FOR HEIGHTS 10'-0" < TO < 15'-0"
 SCALE: NTS

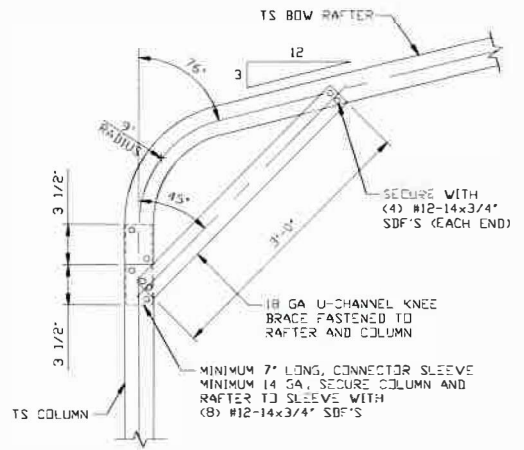

1B
BOW EAVE RAFTER COLUMN CONNECTION DETAIL FOR HEIGHTS < 10'-0"
 SCALE: NTS

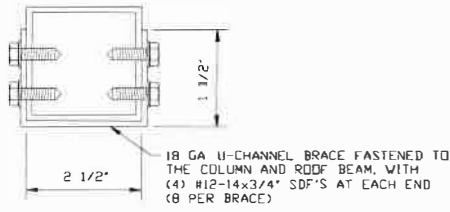

BRACE SECTION
 SCALE: NTS



528 Degan Ave
 Lewisville, Texas 75057

MOORE AND ASSOCIATES ENGINEERING AND CONSULTING, INC.	DRAWN BY: AST	30'-0"x20'-0" ENCLOSED STRUCTURE		
	CHECKED BY: PDH			
THIS DOCUMENT IS THE PROPERTY OF MOORE AND ASSOCIATES ENGINEERING AND CONSULTING. THE UNAUTHORIZED REPRODUCTION, COPYING, OR OTHERWISE USE OF THIS DOCUMENT IS STRICTLY PROHIBITED AND ANY INFRINGEMENT THEREUPON MAY BE SUBJECT TO LEGAL ACTION.	PROJECT MGR: WSM	DATE: 11-11-19	SCALE: NTS	JOB NO: 19262S
		SHT. 0C	DWG. NO: SK-3	REV: 0

BASE RAIL ANCHORAGE OPTIONS

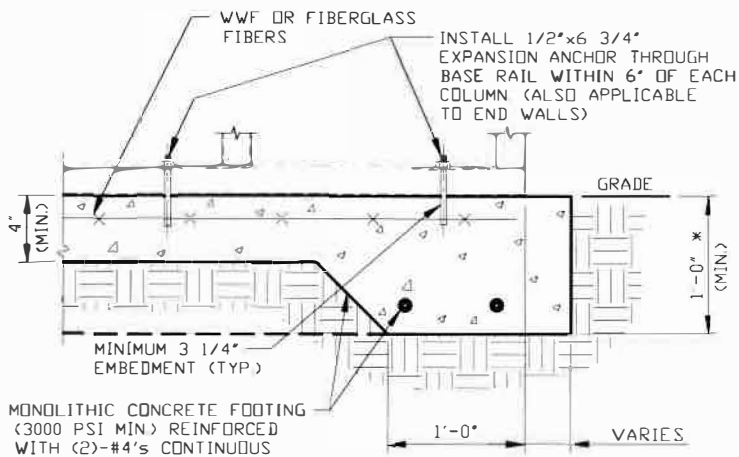

2A

CONCRETE MONOLITHIC SLAB BASE RAIL ANCHORAGE

SCALE: NTS
MINIMUM ANCHOR EDGE DISTANCE IS 4"
* COORDINATE WITH LOCAL BUILDING CODE
AND/OR BUILDING OFFICIAL REGARDING
REQUIRED FOOTING DEPTH

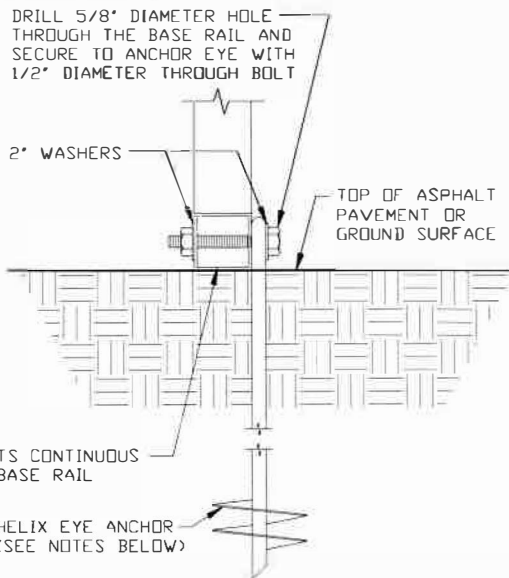

2B

GROUND BASE HELIX ANCHORAGE

SCALE: NTS (CAN BE USED FOR ASPHALT)

GENERAL NOTES

NOTE: CONCRETE MONOLITHIC SLAB DESIGN BASED ON
MINIMUM SOIL BEARING CAPACITY OF 1,500 PSF

CONCRETE:

CONCRETE SHALL HAVE A MINIMUM SPECIFIED COMPRESSIVE
STRENGTH OF 3,000 PSI AT 28 DAYS.

COVER OVER REINFORCING STEEL:

FOR FOUNDATIONS, MINIMUM CONCRETE COVER OVER REINFORCING
BARS SHALL BE PER ACI-318:

3" IN FOUNDATIONS WHERE THE CONCRETE IS CAST AGAINST AND
PERMANENTLY IN CONTACT WITH THE EARTH OR EXPOSED TO THE
EARTH OR WEATHER, AND 1 1/2" ELSEWHERE

REINFORCING STEEL:

THE TURNDOWN REINFORCING STEEL SHALL BE ASTM A615 GRADE
60 THE SLAB REINFORCEMENT SHALL BE WELDED WIRE FABRIC
MEETING ASTM A185 OR FIBERGLASS FIBER REINFORCEMENT

REINFORCEMENT MAY BE BENT IN THE SHOP OR THE FIELD PROVIDED:

- 1 REINFORCEMENT IS BENT COLD.
- 2 THE DIAMETER OF THE BEND, MEASURED ON THE INSIDE OF THE
BAR, IS NOT LESS THAN SIX-BAR DIAMETERS
- 3 REINFORCEMENT PARTIALLY EMBEDDED IN CONCRETE SHALL NOT
BE FIELD BENT

HELIX ANCHOR NOTES:

- 1 FOR VERY DENSE AND/OR CEMENTED SANDS, COARSE GRAVEL
AND COBBLES, CALCICHE, PRELOADED SILTS AND CLAYS, USE
MINIMUM (2) 4" HELICES WITH MINIMUM 30" EMBEDMENT OR
SINGLE 6" HELIX WITH MINIMUM 50" EMBEDMENT
- 2 FOR CORAL USE MINIMUM (2) 4" HELICES WITH MINIMUM
30" EMBEDMENT OR SINGLE 6" HELIX WITH MINIMUM
50" EMBEDMENT
- 3 FOR MEDIUM DENSE COARSE SANDS, SANDY GRAVELS, VERY
STIFF SILTS, AND CLAYS USE MINIMUM (2) 4" HELICES WITH
MINIMUM 30 INCH EMBEDMENT OR SINGLE 6" HELIX WITH MINIMUM
50" EMBEDMENT
- 4 FOR LOOSE TO MEDIUM DENSE SANDS, FIRM TO STIFF CLAYS AND
SILTS ALLUVIAL FILL, USE MINIMUM (2) 6" HELICES WITH MINIMUM
50" EMBEDMENT
- 5 FOR VERY LOSE TO MEDIUM DENSE SANDS, FIRM TO STIFFER
CLAYS AND SILTS, ALLUVIAL FILL, USE MINIMUM (2) 8" HELICES
WITH MINIMUM 60" EMBEDMENT



528 Degan Ave
Lewisville, Texas 75057

MOORE AND ASSOCIATES
ENGINEERING AND CONSULTING, INC.

DRAWN BY: AST

CHECKED BY: PDH

30' -0" x 20' -0" ENCLOSED STRUCTURE

PROJECT MGR: WSM

DATE: 11-11-19

SCALE: NTS

JOB NO: 19262S

SHT. 9

DWG NO: SK-3

REV: 0

THIS DOCUMENT IS THE PROPERTY OF MOORE AND ASSOCIATES ENGINEERING AND CONSULTING. THE UNAUTHORIZED REPRODUCTION, COPYING, OR OTHERWISE USE OF THIS DOCUMENT IS STRICTLY PROHIBITED AND ANY VIOLATION THEREOF MAY BE SUBJECT TO LEGAL ACTION.

BOX EAVE RAFTER END WALL AND SIDE WALL OPENINGS

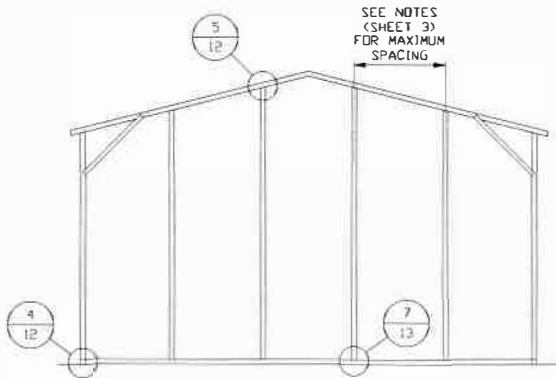

**TYPICAL BOX EAVE RAFTER
END WALL FRAMING SECTION**

SCALE: NTS

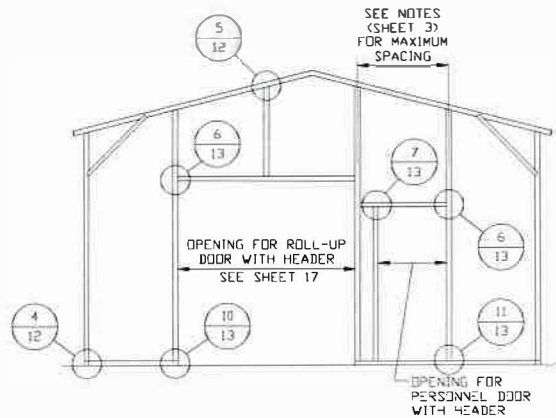

**TYPICAL BOX EAVE RAFTER END
WALL OPENINGS FRAMING SECTION**

SCALE: NTS

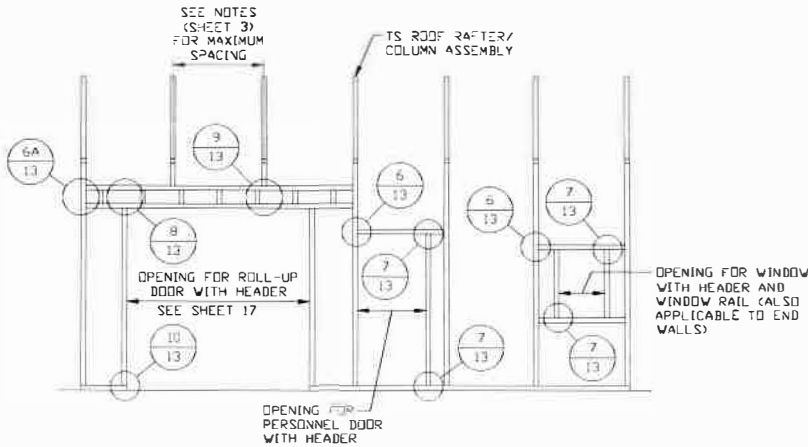

**TYPICAL BOX EAVE RAFTER
SIDE WALL OPENINGS FRAMING SECTION**

SCALE: NTS



528 Degan Ave
Lewisville, Texas 75057

**MOORE AND ASSOCIATES
ENGINEERING AND CONSULTING, INC.**

DRAWN BY: AST

CHECKED BY: PDH

PROJECT MGR: WSM

30'-0"X20'-0" ENCLOSED STRUCTURE

DATE: 11-11-19

SCALE: NTS

JOB NO: 19262S

SHT. 10

DWG. NO: SK-3

REV: 0

THIS DOCUMENT IS THE PROPERTY OF MOORE AND ASSOCIATES ENGINEERING AND CONSULTING. THE UNAUTHORIZED REPRODUCTION, COPYING, OR OTHERWISE USE OF THIS DOCUMENT IS STRICTLY PROHIBITED AND ANY INFRINGEMENT THEREUPON MAY BE SUBJECT TO LEGAL ACTION.

BOW RAFTER END WALL AND SIDE WALL OPENINGS

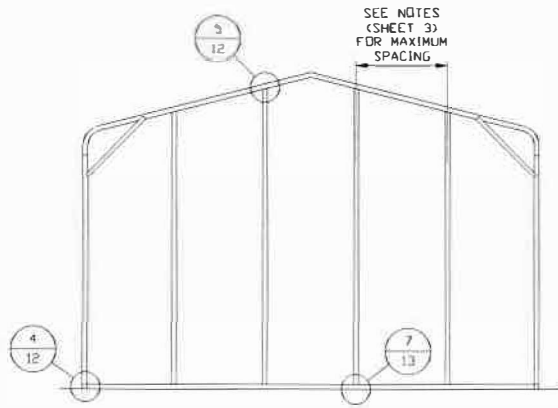

**TYPICAL BOW RAFTER
END WALL FRAMING SECTION**

SCALE: NTS

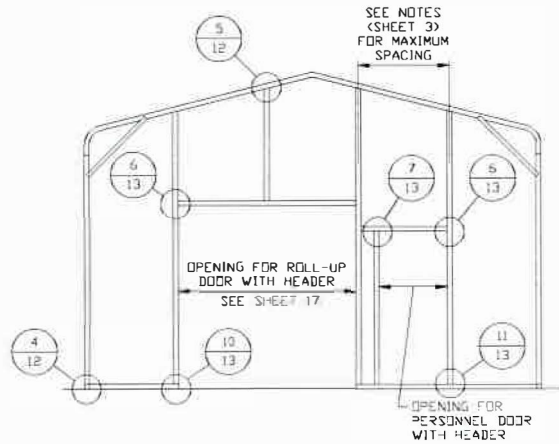

**TYPICAL BOW RAFTER END
WALL OPENINGS FRAMING SECTION**

SCALE: NTS

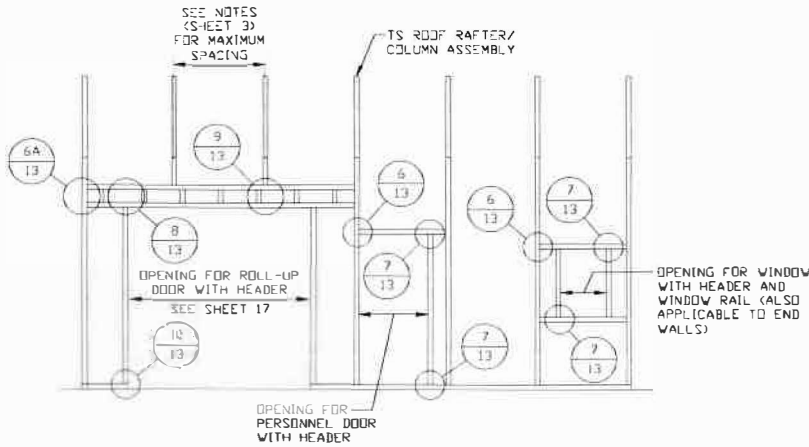

**TYPICAL BOW RAFTER SIDE
WALL OPENINGS FRAMING SECTION**

SCALE: NTS



**528 Degan Ave
Lewisville, Texas 75057**

**MOORE AND ASSOCIATES
ENGINEERING AND CONSULTING, INC.**

DRAWN BY: AST

CHECKED BY: PDH

30'-0" x 20'-0" ENCLOSED STRUCTURE

PROJECT MGR: WSM

DATE: 11-11-19

SCALE: NTS

JOB NO: 19262S

THIS DOCUMENT IS THE PROPERTY OF MOORE AND ASSOCIATES ENGINEERING AND CONSULTING. THE UNAUTHORIZED REPRODUCTION, COPYING, OR OTHERWISE USE OF THIS DOCUMENT IS STRICTLY PROHIBITED AND ANY INFRINGEMENT THEREUPON MAY BE SUBJECT TO LEGAL ACTION.

SHT. 11

DWG. NO: SK-3

REV: 0

CONNECTION DETAILS

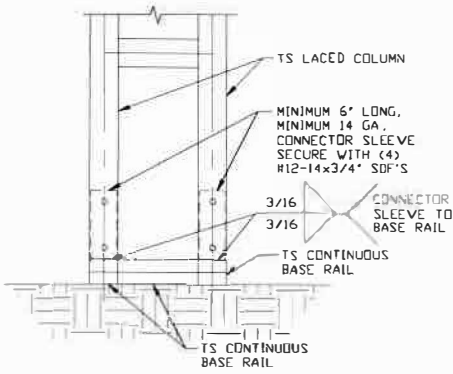

3
**RAFTER COLUMN/
 BASE RAIL
 CONNECTION DETAIL**
 SCALE: NTS

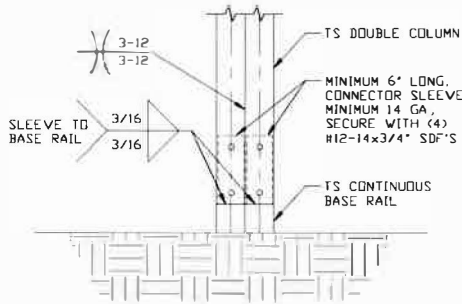

3A
**RAFTER COLUMN/
 BASE RAIL
 CONNECTION DETAIL**
 SCALE: NTS

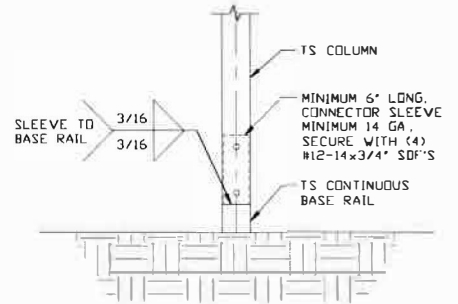

3B
**RAFTER COLUMN/
 BASE RAIL
 CONNECTION DETAIL**
 SCALE: NTS

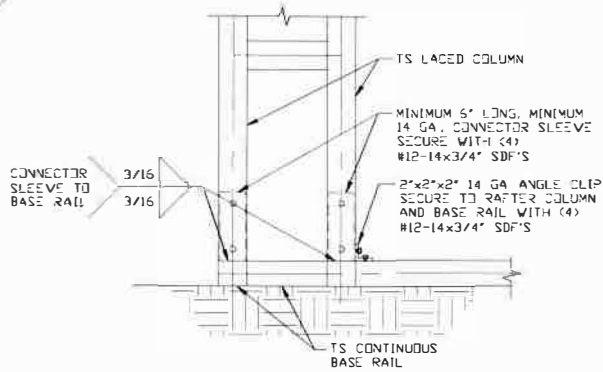

4
**END COLUMN/
 BASE RAIL
 CONNECTION DETAIL**
 SCALE: NTS

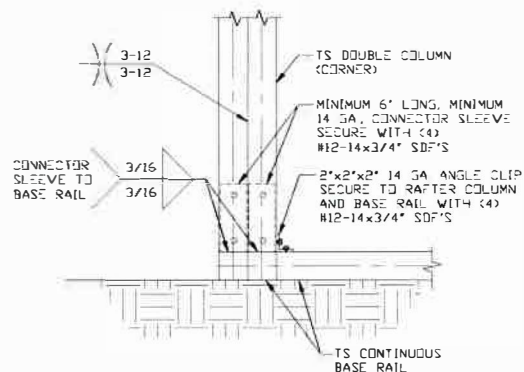

4A
**END COLUMN/
 BASE RAIL
 CONNECTION DETAIL**
 SCALE: NTS

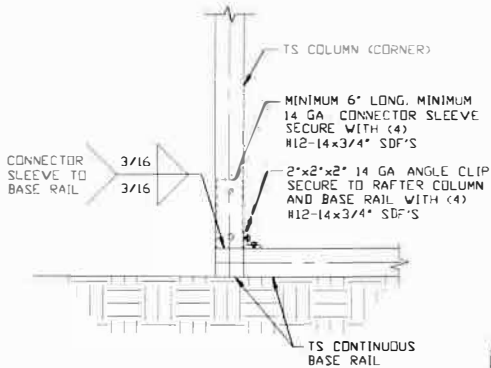

4B
**END COLUMN/
 BASE RAIL
 CONNECTION DETAIL**
 SCALE: NTS

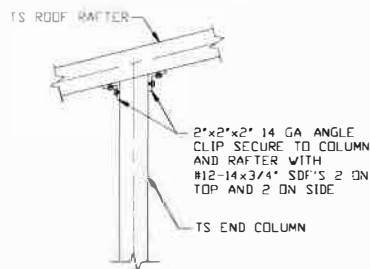

5
**END COLUMN/RAFTER
 CONNECTION DETAIL**
 SCALE: NTS



528 Degan Ave
 Lewisville, Texas 75057

MOORE AND ASSOCIATES
 ENGINEERING AND CONSULTING, INC.

DRAWN BY: AST

CHECKED BY: PDH

30'-0" x 20'-0" ENCLOSED STRUCTURE

PROJECT MGR: WSM

DATE: 11-11-19

SCALE: NTS

JOB NO: 19262S

THIS DOCUMENT IS THE PROPERTY OF MOORE AND ASSOCIATES ENGINEERING AND CONSULTING, INC. UNAUTHORIZED REPRODUCTION, COPYING, OR OTHERWISE USE OF THIS DOCUMENT IS STRICTLY PROHIBITED AND ANY INFRINGEMENT THEREUPON MAY BE SUBJECT TO LEGAL ACTION.

SHT. 12

DWG. NO: SK-3

REV.: 0

CONNECTION DETAILS

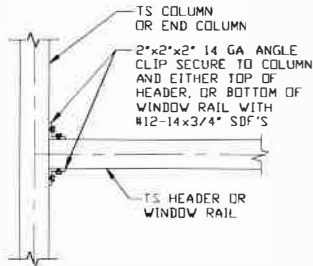

6 COLUMN OR WINDOW RAIL/GIRT TO POST CONNECTION DETAIL
SCALE: NTS

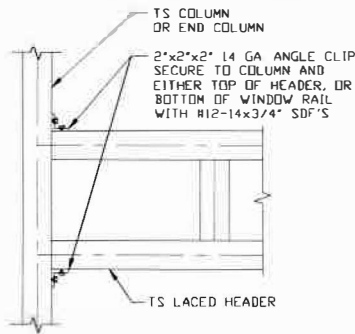

6A LACED HEADER/COLUMN CONNECTION DETAIL
SCALE: NTS

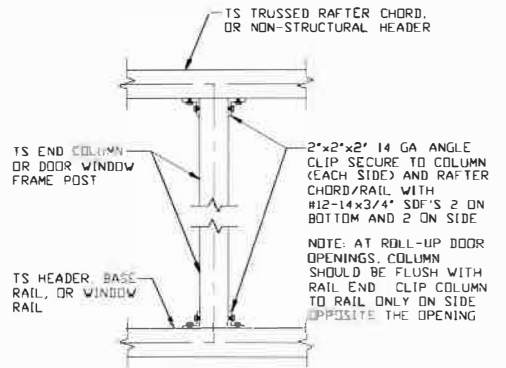

7 COLUMN TO WINDOW RAIL CONNECTION DETAIL
SCALE: NTS

NOTE: AT ROLL-UP DOOR OPENINGS, COLUMN SHOULD BE FLUSH WITH RAIL END CLIP COLUMN TO RAIL ONLY ON SIDE OPPOSITE THE OPENING

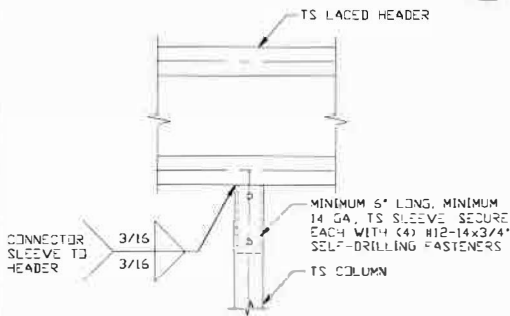

8 LACED HEADER/COLUMN CONNECTION DETAIL
SCALE: NTS

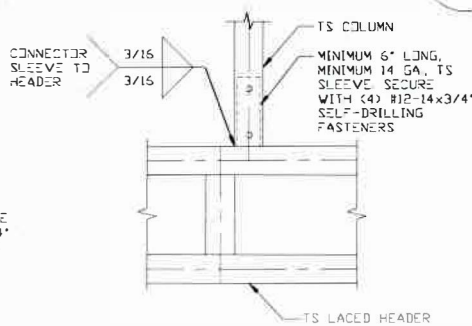

9 COLUMN/LACED HEADER CONNECTION DETAIL
SCALE: NTS

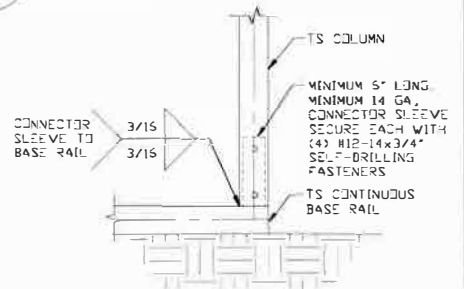

10 COLUMN/BASE RAIL CONNECTION DETAIL
SCALE: NTS

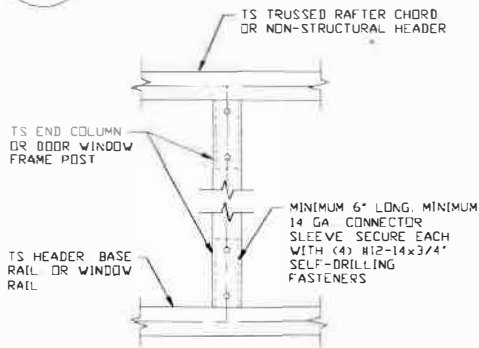

11 COLUMN TO HEADER OR BASE RAIL CONNECTION DETAIL
SCALE: NTS

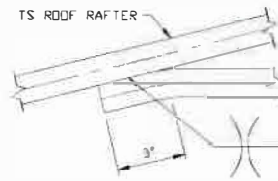

12 COLLAR TIE CONNECTION DETAIL
SCALE: NTS

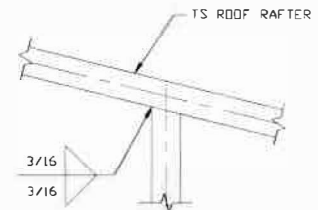

13 RAFTER TO CHORD CONNECTION DETAIL
SCALE: NTS



528 Degan Ave
Lewisville, Texas 75057

MOORE AND ASSOCIATES
ENGINEERING AND CONSULTING, INC.

DRAWN BY: AST

CHECKED BY: PDH

PROJECT MGR: WSM

3.0-0"x20'-0" ENCLOSED STRUCTURE

DATE: 11-11-19

SCALE: NTS

JOB NO: 19262S

SHT. 13

DWG. NO: SK-3

REV: 0

THIS DOCUMENT IS THE PROPERTY OF MOORE AND ASSOCIATES ENGINEERING AND CONSULTING. THE UNAUTHORIZED REPRODUCTION, COPYING, OR OTHERWISE USE OF THIS DOCUMENT IS STRICTLY PROHIBITED AND ANY INFRINGEMENT THEREUPON MAY BE SUBJECT TO LEGAL ACTION.

BOX EAVE RAFTER LEAN-TO OPTIONS

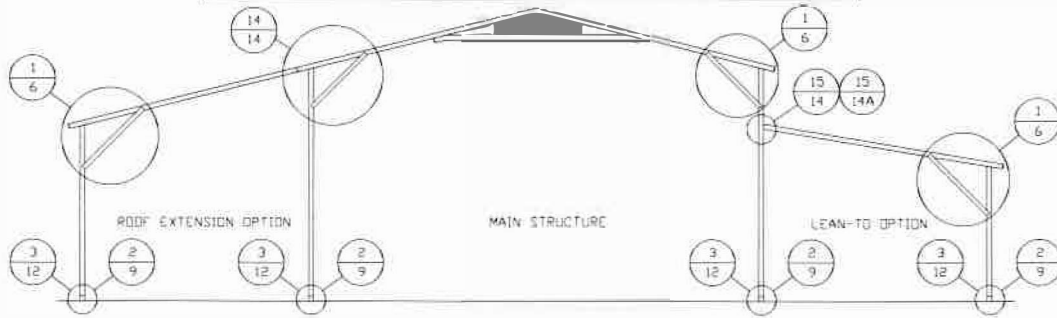

TYPICAL BOX EAVE RAFTER LEAN-TO OPTIONS FRAMING SECTION (BOTH OPTIONS SHOWN)

SCALE: NTS

MAXIMUM WIDTH OF DOUBLE TUBE MEMBER (RAFTER AND COLUMN) ROOF EXTENSION AND LEAN-TO IS 16'-0"

MAXIMUM WIDTH OF SINGLE TUBE MEMBER (RAFTER AND COLUMN) ROOF EXTENSION AND LEAN-TO IS 12'-0"

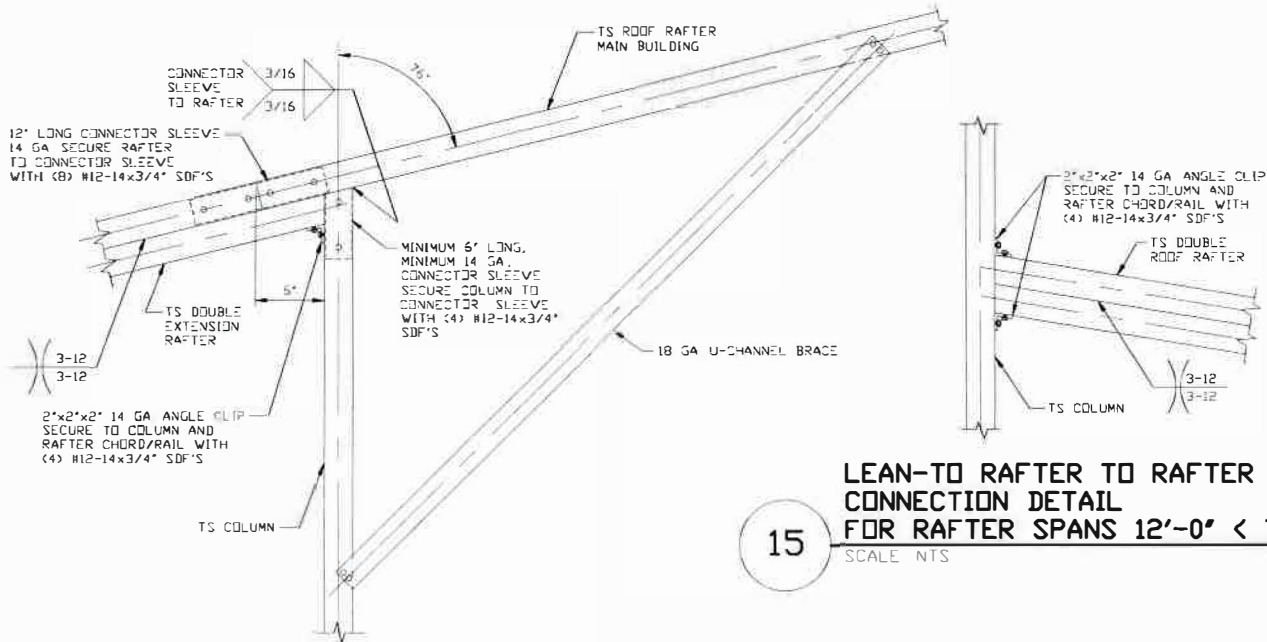

LEAN-TO RAFTER TO RAFTER COLUMN CONNECTION DETAIL FOR RAFTER SPANS 12'-0" < TO <= 16'-0"

15

SCALE: NTS

14 SIDE EXTENSION RAFTER/ COLUMN DETAIL FOR RAFTER SPANS <= 16'-0"

SCALE: NTS

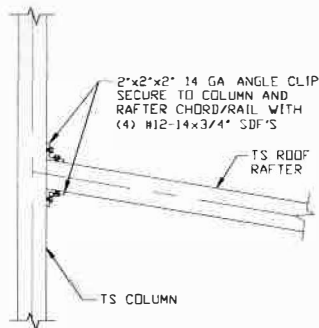

15A

LEAN-TO RAFTER TO RAFTER COLUMN CONNECTION DETAIL FOR RAFTER SPANS <= 12'-0"

SCALE: NTS



528 Degan Ave
Lewisville, Texas 75057

**MOORE AND ASSOCIATES
ENGINEERING AND CONSULTING, INC.**

DRAWN BY: AST

CHECKED BY: PDH

30'-0" x 20'-0" ENCLOSED STRUCTURE

PROJECT MGR: VSM

DATE: 11-11-19

SCALE: NTS

JOB NO: 19262S

SHT. 14

DWG. NO: SK-3

REV: 0

THIS DOCUMENT IS THE PROPERTY OF MOORE AND ASSOCIATES ENGINEERING AND CONSULTING. THE UNAUTHORIZED REPRODUCTION, COPYING, OR OTHERWISE USE OF THIS DOCUMENT IS STRICTLY PROHIBITED AND ANY INFRINGEMENT THEREUPON MAY BE SUBJECT TO LEGAL ACTION.

BOX EAVE RAFTER LEAN-TO OPTIONS

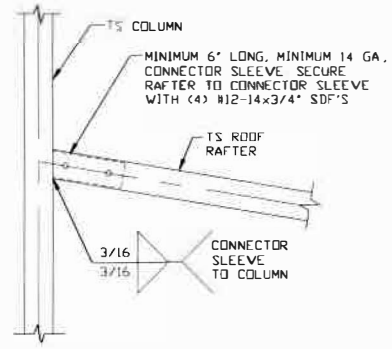
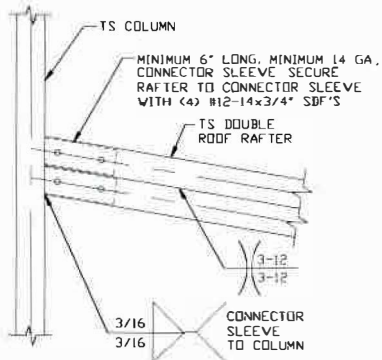

15B LEAN-TO RAFTER TO RAFTER COLUMN CONNECTION DETAIL FOR RAFTER SPANS 12'-0" < TO ≤ 16'-0"
SCALE: NTS

15C LEAN-TO RAFTER TO RAFTER COLUMN CONNECTION DETAIL FOR RAFTER SPANS ≤ 12'-0"
SCALE: NTS



528 Degan Ave
Lewisville, Texas 75057

MOORE AND ASSOCIATES ENGINEERING AND CONSULTING, INC.	DRAWN BY: AST	30'-0"x20'-0" ENCLOSED STRUCTURE		
	CHECKED BY: PDH			
THIS DOCUMENT IS THE PROPERTY OF MOORE AND ASSOCIATES ENGINEERING AND CONSULTING, INC. UNAUTHORIZED REPRODUCTION, COPYING, OR OTHERWISE USE OF THIS DOCUMENT IS STRICTLY PROHIBITED AND ANY VIOLATION THEREUPON MAY BE SUBJECT TO LEGAL ACTION.	PROJECT MGR: VSM	DATE: 11-11-19	SCALE: NTS	JOB NO: 19262S
		SHT. 14A	DVG. NO: SK-3	REV: 0

BOW EAVE RAFTER LEAN-TO OPTION

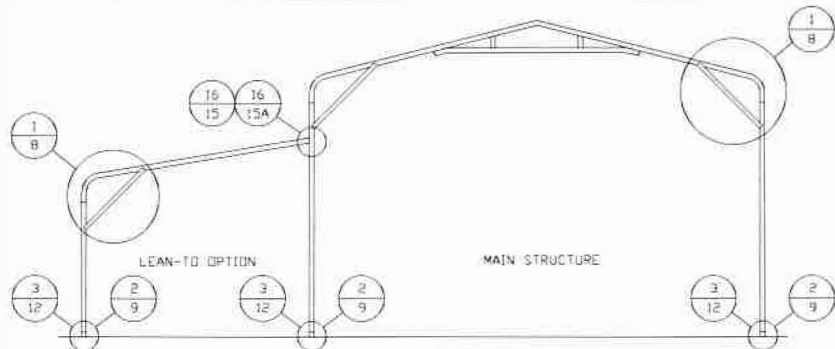

TYPICAL BOW RAFTER LEAN-TO OPTION FRAMING SECTION

SCALE: NTS
 MAXIMUM WIDTH OF DOUBLE TUBE MEMBER (RAFTER AND COLUMN) ROOF EXTENSION AND LEAN-TO IS 16'-0"
 MAXIMUM WIDTH OF SINGLE TUBE MEMBER (RAFTER AND COLUMN) ROOF EXTENSION AND LEAN-TO IS 12'-0"

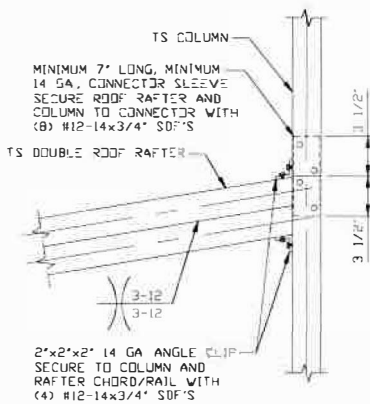

16

**LEAN-TO RAFTER TO RAFTER
 COLUMN CONNECTION DETAIL
 FOR RAFTER SPANS 12'-0" < TO ≤ 16'-0"**

SCALE: NTS

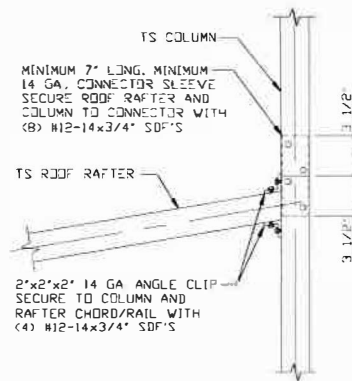

16A

**LEAN-TO RAFTER TO RAFTER
 COLUMN CONNECTION DETAIL
 FOR RAFTER SPANS ≤ 12'-0"**

SCALE: NTS

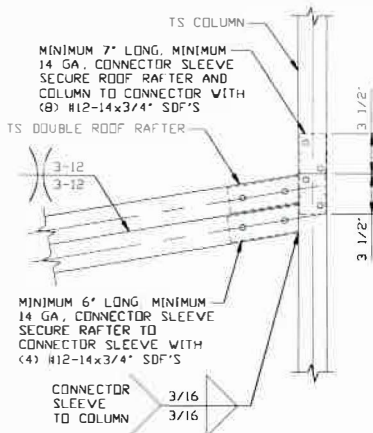

16B

**LEAN-TO RAFTER TO RAFTER
 COLUMN CONNECTION DETAIL
 FOR RAFTER SPANS 12'-0" < TO ≤ 16'-0"**

SCALE: NTS



528 Degan Ave
 Lewisville, Texas 75057

**MOORE AND ASSOCIATES
 ENGINEERING AND CONSULTING, INC.**

DRAWN BY: AST

CHECKED BY: PDH

30' -0"x200" ENCLOSED STRUCTURE

PROJECT MGR: VSM

DATE: 11-11-19

SCALE: NTS

JOB NO: 19262S

THIS DOCUMENT IS THE PROPERTY OF MOORE AND ASSOCIATES ENGINEERING AND CONSULTING. THE UNAUTHORIZED REPRODUCTION, COPYING, OR OTHERWISE USE OF THIS DOCUMENT IS STRICTLY PROHIBITED AND ANY INFRACTION THEREUPON MAY BE SUBJECT TO LEGAL ACTION.

SHT. 15

DWG. NO: SK-3

REV: 0

BOW EAVE RAFTER LEAN-TO OPTION

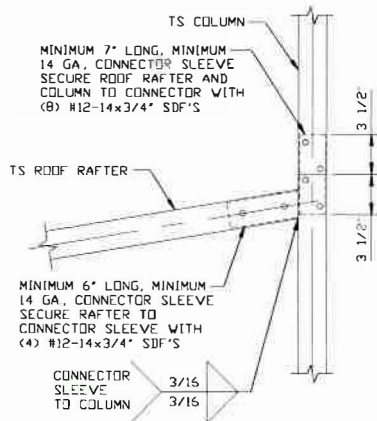

**LEAN-TO RAFTER TO RAFTER
COLUMN CONNECTION DETAIL
FOR RAFTER SPANS \leq 12'-0"**

16C

SCALE: NTS



528 Degan Ave
Lewisville, Texas 75057

**MOORE AND ASSOCIATES
ENGINEERING AND CONSULTING, INC.**

DRAWN BY: AST

CHECKED BY: PDH

30'-0" x 20'-0" ENCLOSED STRUCTURE

PROJECT MGR: WSH

DATE: 11-11-19

SCALE: NTS

JOB NO: 19262S

THIS DOCUMENT IS THE PROPERTY OF MOORE AND ASSOCIATES ENGINEERING AND CONSULTING. THE UNAUTHORIZED REPRODUCTION, COPYING, OR OTHERWISE USE OF THIS DOCUMENT IS STRICTLY PROHIBITED AND ANY INFRINGEMENT THEREUPON MAY BE SUBJECT TO LEGAL ACTION.

SHT. 15A

DWG. NO: SK-3

REV: 0

BOX EAVE RAFTER VERTICAL ROOF/SIDING OPTION

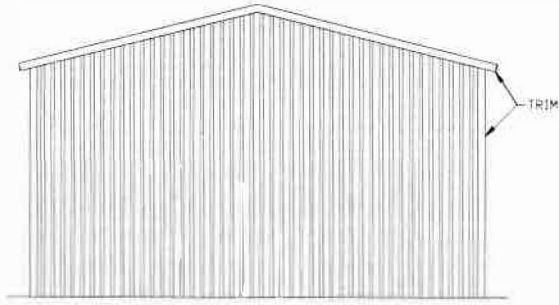

**TYPICAL END ELEVATION
VERTICAL ROOF/SIDING**

SCALE: NTS

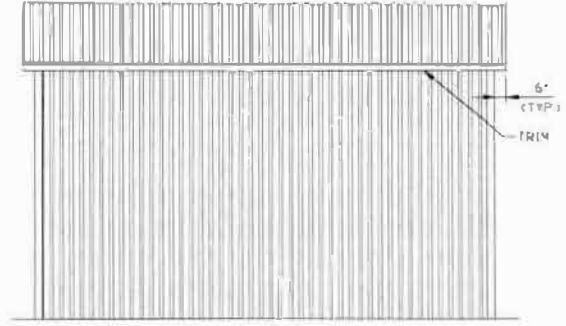

**TYPICAL SIDE ELEVATION
VERTICAL ROOF/SIDING**

SCALE: NTS

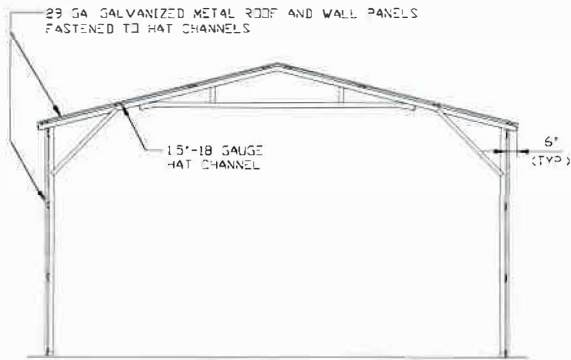

**TYPICAL SECTION VERTICAL
ROOF/SIDING OPTION**

SCALE: NTS

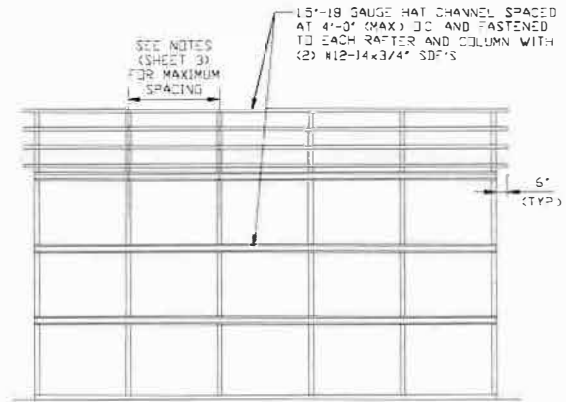

**TYPICAL FRAMING SECTION
VERTICAL ROOF/SIDING OPTION**

SCALE: NTS

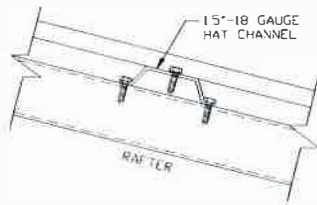

PANEL ATTACHMENT

(ALTERNATE FOR VERTICAL ROOF AND WALL PANELS)
SCALE: NTS



**528 Degan Ave
Lewisville, Texas 75057**

**MOORE AND ASSOCIATES
ENGINEERING AND CONSULTING, INC.**

DRAWN BY: AST

CHECKED BY: PDH

PROJECT MGR: VSM

30'-0"x20'-0" ENCLOSED STRUCTURE

DATE: 11-11-19

SHT. 16

SCALE: NTS

DWG. NO: SK-3

JOB NO: 19262S

REV: 0

THIS DOCUMENT IS THE PROPERTY OF MOORE AND ASSOCIATES ENGINEERING AND CONSULTING. THE UNAUTHORIZED REPRODUCTION, COPYING, OR OTHERWISE USE OF THIS DOCUMENT IS STRICTLY PROHIBITED AND ANY INFRINGEMENT THEREUPON MAY BE SUBJECT TO LEGAL ACTION.

HEADER OPTION

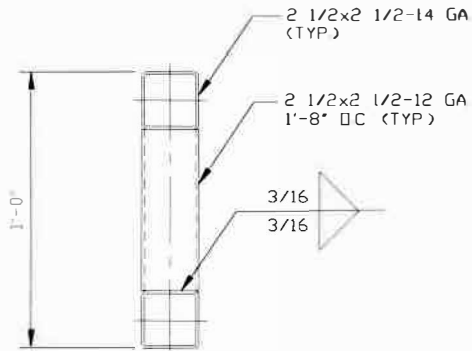

HEADER DETAIL FOR SIDE WALL DOOR OPENINGS \leq 16'-0"

SCALE: NTS

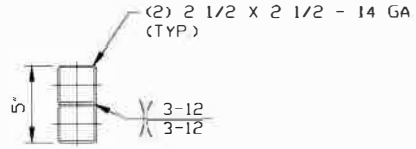

HEADER DETAIL FOR END WALL DOOR OPENINGS \leq 16'-0"

SCALE: NTS

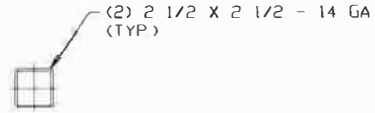

HEADER DETAIL FOR END WALL DOOR OPENINGS \leq 14'-0"

SCALE: NTS

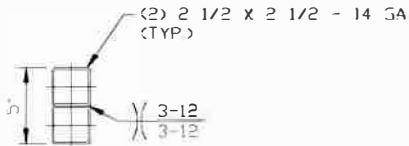

HEADER DETAIL FOR SIDE WALL DOOR OPENINGS \leq 14'-0"

SCALE: NTS

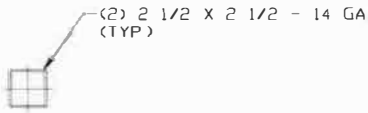

HEADER DETAIL FOR SIDE WALL DOOR OPENINGS \leq 8'-0"

SCALE: NTS



528 Degan Ave
Lewisville, Texas 75057

**MOORE AND ASSOCIATES
ENGINEERING AND CONSULTING, INC.**

DRAWN BY: AST

CHECKED: BYPDH

30' -0"x20' 0" ENCLOSED STRUCTURE

PROJECT MGR: VSM

DATE: 11-11-19

SCALE: NTS

JOB NO: 19262S

SHT. 17

DWG. NO: SK-3

REV: 0

THIS DOCUMENT IS THE PROPERTY OF MOORE AND ASSOCIATES ENGINEERING AND CONSULTING. THE UNAUTHORIZED REPRODUCTION, COPYING, OR OTHERWISE USE OF THIS DOCUMENT IS STRICTLY PROHIBITED AND ANY INFRACTION THEREUPON MAY BE SUBJECT TO LEGAL ACTION.